



CONTROLS GUIDE

APPLICATIONS MAPPED TO CONTROLS

be
think
innovate

GRUNDFOS 

FOREWORD

Do you need controls?

The demands for controls increase and are often requested on pumps, when it comes to optimum operation, high reliability and monitoring of data.

Therefore, Grundfos has updated the Controls Guide, which gives in a simple manner an overview about applications and the related controls of speed controlled pumps and pump systems.

We have elaborated a Guide for engineers and technicians who work with design and installation of pumps and pump systems, containing answers to a wide range of controls for pumps. The handbook can either be read from one end to the other or partly on specific topics. The handbook is divided into chapters which deal with different applications and pump systems.

Additional to the mentioned controllers there is a huge variety of electronic speed regulated pumps which can be used in several applications when only a single pump is needed. Details of the respective controller and pumps you can find in the related databooklets of the products.

We sincerely hope that you will make use of the Guide and find it useful in your daily work.

Markus Reichling

Global Product Manager

- August 2018 -

Controls guide

Copyright 2013 GRUNDFOS Holding A/S.

All rights reserved. Copyright law and international treaties protect this material. No part of this material may be reproduced in any form or by any means without prior written permission from GRUNDFOS Holding A/S.

Disclaimer

All reasonable care has been taken to ensure the accuracy of the contents of this material, however GRUNDFOS Holding A/S shall not be reliable for any loss whether direct, indirect, incidental or consequential arising out of the use of or reliance upon any of the content of the material.





TABLE OF CONTENT

System	Application area	Page
1. Heating	Medium/ large buildings	6
2. District heating	Campus/ large scale DH	14
3. Air-conditioning	Medium/ large buildings	26
4. District cooling	Campus/ large scale DC	36
5. Pressure boosting	Medium/ large buildings	44
5.B. Rainwater	Medium/ large buildings	50
6. Wastewater	Medium/ large buildings	52
7. Fire	Medium/ large buildings	58
8. Const. pressure & On/Off	Industry	60
9. Temperature control	Industry	62
10. Boiler feed	Industry	64
11. Level control	Industry	66
12. Wash'n'clean	Industry	68

System	Application area	Page
13. Filter application	Industry	70
14. Industrial Water Treatment	Industrial Water Treatment	72
15. Water Intake	Municipal waterworks	74
16. Treatment Process	Municipal waterworks	78
17. Water distribution	Municipal waterworks	84
18. WW transport	Municipal wastewater	88
19. WW treatment	Municipal wastewater	93
20. Irrigation	Irrigation	98
21. Solar water solution	Solar water solution	100
Portfolio of Sensors & Frequency converter		102
Portfolio of Communication & Motor protection		104
Portfolio of Controls		106
Further information		

1. HEATING

MEDIUM/LARGE BUILDINGS

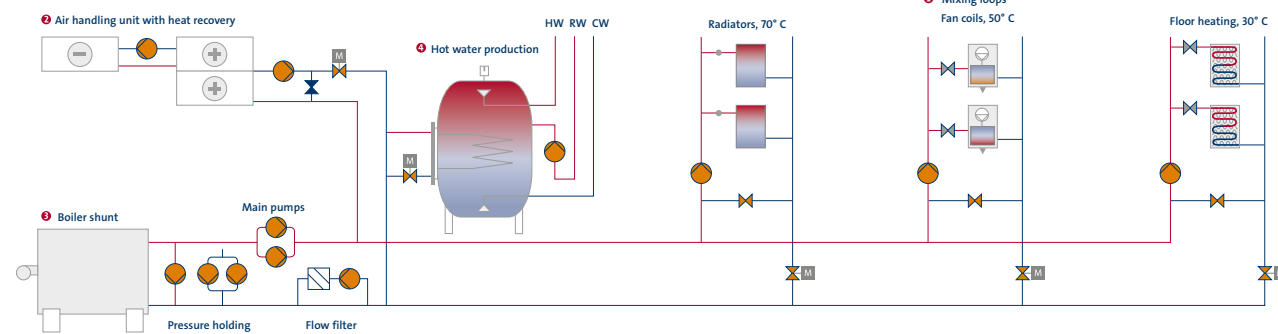

Plan heating systems from the outside in

Knowing the flows and temperatures required for radiators, under-floor heating, etc., lets you design your system based on known demands on central equipment. Our external controls and integrated frequency converters ensure maximum system intelligence, flexibility and the lowest costs.

Think about the whole system

In heating systems, energy efficient pumps are only half the story. With the right system design, you can minimise energy consumption, increase comfort levels and future-proof your building.

Speed control

Speed-controlled pumps are key to an efficient and noiseless system. Grundfos speed-controlled pumps can be controlled by variations in pressure, temperature, flow, differential pressure or any other specific measurable parameter. This ensures high efficiency, low energy consumption and ultimately the best life

cycle cost.

The term central heating covers hydronic heating systems with a central boiler or furnace either inside the building being heated or in the immediate vicinity.

Heat is generated in the boiler. Pipes carry the heated water to the buildings heat sources (radiators) and returns the cooled water to the boiler again.

Originally, many central heating systems were designed to be self-circulating. Now a circulator is always used to pump heat through the system.

A central heating system is a closed system with either an expansion tank or open expansion vessel. A buffer tank can also be installed in these systems.

A wide range of fuel types are used in central heating. Coal, coke, wood, oil, gas, wood chips and wood pellets have all proven adequate fuel sources in central heating boilers



1.1 MAIN PUMPS

Main Pumps

Due to variation in the heat demand and the flow, we recommend to use speed controlled pumps in parallel as main pumps. Maximum 3 pumps plus 1 as standby pump. By speed controlling all the pumps it is possible to obtain the maximum energy saving.

It is important to check the efficiency at the duty point where the system has a high number of operating hours.

Using MAGNA3 and TPE3 no external pressure sensor and motor protection is necessary, only a ControlMPC is needed for parallel operation of TPE pumps. 2 MAGNA3 or 2 TPE3 pumps can work in parallel without external controller. It is possible to have proportional pressure without a sensor placed in the system.

For pumps above 22 kW both external sensor, motor protection and a pump control unit is necessary.

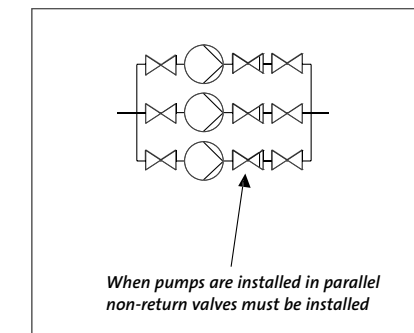
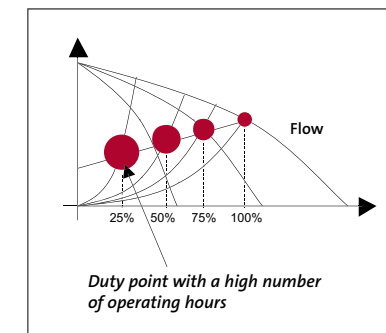
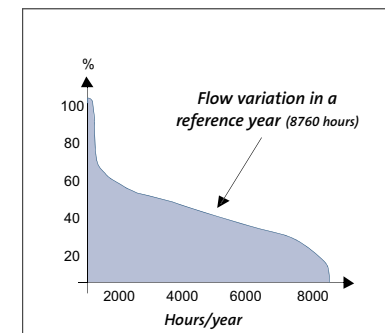

Recommended product types: Differential pressure control	Control (depend on connected sensor)	Features Pumps													Pumps															
		single pump duty / standby	parallel cascade operation	Non e-pump Relay outputs	Grundfos GO communication	RI00 Infrared communication	BACnet MS/TP or BACnet IP communication	LONWorks data communication	PROFIBUS DP / PROFINET data communication	Modbus RTU data communication	EtherNet/IP data communication	Modbus TCP data communication	3G/4G cellular data communication	CIU/ GRM data communication (Grundfos Remote Management) *8)	GENIBus data communication	Ethernet (VNC Server) data communication	No external sensor required	Sensor (0/4-20mA / 0-10V)	Sensor installed over the pump	Sensor installed in the system	Analogue setpoint influence (0-10 V)	Graphic display with user interface	Start-up wizard	Motor protection	TP	NB, NK				
MAGNA3	Δp,A,PP,S,F,T,P,FA	x	x	*1)	2	x		*9)	*9)	*9)	*9)	*9)	*9)	*9)	x	x	x	x	x	x	x	x	x	x	x	x				
TPE series 2000	Δp	x	*2)	*3)	*4)	x	x	*5)	*5)	*5)	*5)	*5)	*5)	*5)	*5)	*5)	*5)	*5)	*5)	*5)	*5)	*5)	*5)	*5)	*5)	*5)	*5)	*5)		
TPE3 (MGE model H/I/J)	Δp, A, P, S, F, T	x	x	x	2	x	x	*5)	*5)	*5)	*5)	*5)	*5)	*5)			*11)	*11)	x	x	x	x	x	x	x	x	x			
E-pump TPE, NBE, NKE	Δp, A, S, F, T, P, FA	x	x	*3)	*4)	x	x	*5)	*5)	*5)	*5)	*5)	*5)	*5)					x	x	x	x	x	x	x	x	x			
E-pump TPE, NBE, NKE (MGE model H/I/J)	Δp, A, F, T, P, FA	x	x	x	2	x		*5)	*5)	*5)	*5)	*5)	*5)	*5)					x	x	x	x	x	x	x	x	x			
Control MPC (CU352)	Δp, PP, S, F, Dt, T, P	x	x	x	2			*9)	*9)	*9)	*9)	*9)	*9)	*9)	x				x	x	x	x	x	x	x	x	x	x		
Control MPC series 2000 (CU352)	Δp, PP, S, F, Dt, T, P	x	x		2			*9)	*9)	*9)	*9)	*9)	*9)	*9)	x				x	x	x	x	x	x	x	x	x	x		
CUE (Frequency converter)	Δp, PP, S, F, Dt, T, P, L	x	x	*3)	x	2		*10)	*10)	*10)	*10)	*10)	*10)	*10)	x				x	x	x	x	x	x	x	x	x	x		
MP204 (Motorprotection)		x			x	1	x			*10)	*10)	*10)	*10)	*10)	x													x	x	

A= Autoadapt, Dp= Differential Pressure, P= Const. Pressure, PP= Proportional Pressure, T= Const. Temperature, Dt= Differential Temperature, F= Const Flow, S= Const. Speed/Frequency, L=Level, pH=pH-Wert, Cl2= Chlorine, ClO2=Chlorine dioxide, O3=Ozone, PAA=Peracetic acid, H2O2=Hydrogen peroxide, FA=FlowAdapt

*1) MAGNA3 cascade up to 2 pumps without ext. controller
 *2) TPED
 *3) E-pumps MGE model H/I/J cascade up to 2 pumps, with external Control MPC cascade up to 6 pumps possible. Note: data point "heat energy" only on twinpump available.
 *4) All MGEs model H/I/J: 2 relays
 *5) MGE model H/I/J: CIM interfaces, TPED and MGE model F/G and TPE mod. J: CIU interfaces
 *6) version CIU xx2 needed
 *7) DDA: E-Box, DDA XL: CIU
 *8) for GRM alternative solution: G501
 *9) CIM interfaces
 *10) CIU interfaces
 *11) incl. differential pressure sensor
 *12) 4-20 mA Sensor required x available
 *13) order a CIU 903 and a CIM 280 and mount CIM into CIU 903 CIM 280 support 3G/4G cellular technology and require an additiona 3G/4G antenna and a related SIM card.

1.2 BOILER SHUNT PUMP

Boiler shunt pump

The primary task of the boiler shunt pump is to ensure that the temperature differences between top and bottom of the boiler are not too big, big temperature differences cause tension in the material and thus reduce the life of the boiler. For certain types of fuel there is a risk of corrosion at too low temperatures at the bottom of the boiler. Maximum safety is ensured when using a controlled pump, and the energy saving is optimal.

TPE: The pumps have an integrated frequency converter and motor protection.
 A temperature transmitter with an output signal of 0-10V or 0/4-20 mA should be used. Grundfos GO remote control is used for start-up and later for extracting operating data.
 TP/NK: These pump types require an external frequency converter (e.g. CUE) and an external regulator

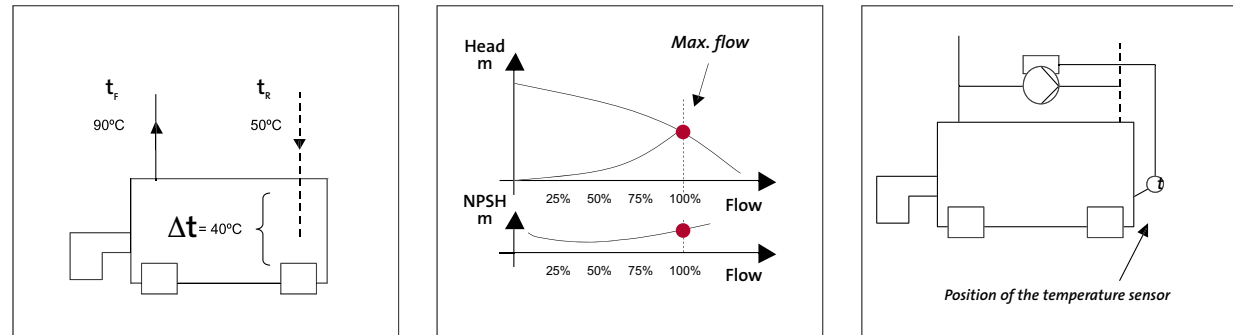

Boiler shunt pumps		Features Pumps																	Pumps							
Recommended product types: Temperature control	Control (depend on connected sensor)	single pump	parallel cascade operation	Relay outputs	Groundfos GO communication	RTD0 Infrared communication	BACnet MS/TP or BACnet IP communication	LONWorks data communication	PROFIBUS DP/ PROFINET data communication	Modbus RTU data communication	EtherNet/IP data communication	Modbus TCP data communication	3C/4G cellular data communication	GIC/ GRM (Grundfos Remote Management) *8)	GENibus data communication	Ethernet (VNC Server) data communication	No external sensor required	Sensor (0)4-20mA / 0-10V	Sensor installed over the pump	Sensor installed in the system	Analogue setpoint influence (0-10 V)	Graphic display with user interface	Start-up wizard	Motor protection	TP	NB, NK
		MAGNA3	Δp,A,PP,S,F,T,P,FA	x	x	*1)	2	x	*9)	*9)	*9)	*9)	*9)	*9)	*9)	*9)	x	x	x	x	x	x	x	x	x	x
E-pump TPE, NBE, NKE	Δp,A,S,F,T,P,FA	x	x	*3)	*4)	x	*5)	*5)	*5)	*5)	*5)	*5)	*5)					x	x	x	x	x	x	x		
E-pump TPE,NBE,NKE (MGE model H/I/J)	Δp,A,S,F,T,P,FA	x	x	x	2	x	*5)	*5)	*5)	*5)	*5)	*5)	*5)					x	x	x	x	x	x	x		
CUE (Frequency converter)	Δp,PP,S,F,Dt,T,P,L	x	x	*3)	x	2		*10)	*10)	*10)	*10)	*10)	*10)	x				x	x	x	x	x	x	x	x	x
MP204 (Motorprotection)		x			1	x	x		*10)	*10)		*10)	*10)	x										x	x	x

A= Autoadapt, Dp= Differential Pressure, P= Const. Pressure, PP= Propotional Pressure, T= Const. Temperature, DT= Differential Temperature, F= Const Flow, S= Const. Speed/Frequency, L=Level, pH=pH-Wert, Cl2= Chlorine, ClO2=Chlorine dioxide, O3=Ozone, PAA=Peracitic acid, H2O2=Hydrogen peroxide , FA=FlowAdapt

- *1) MAGNA3 cascade up to 2 pumps without ext. controller
- *2) TPED
- *3) E-pumps MGE model H/I/J cascade up to 2 pumps, with external Control MPC cascade up to 6 pumps possible. Note: data point "heat energy" only on twinpump available.
- *4) All MGEs model H/I/J: 2 relays
- *5) MGE model H/I/J: CIM interfaces, TPED and MGE model F/G and TPE mod. J: CIU interfaces
- *6) version CIM xx2 needed
- *7) DDA Option E-Box Profibus
- *8) for GRM alternative solution: G501
- *9) CIM interfaces
- *10) CIU interfaces
- *11) incl. differential pressure sensor
- *12) 4-20 mA Sensor required
- x available

1.3.MIXING LOOPS

Mixing loops

Due to variation in use and heat demand in different parts of the building, the system is divided into zones controlled by a mixing loop. The flow temperature will be lower than in the mains supply, which will result in a higher flow in the zone than in the mains supply. This will help obtain a better hydraulic balance in the total system. Speed controlling the pump makes it possible to obtain the maximum energy saving.

When using a two-way valve, the pressure lost in the valve will be managed by the main pump. When using a three-way valve, the pump in the mixing loop also has to manage the pressure lost in the valve.

Using MAGNA3 and TPE3 pumps there is no need for an external pressure sensor and a motor protection. It is possible to have proportional pressure without a sensor placed in the system.

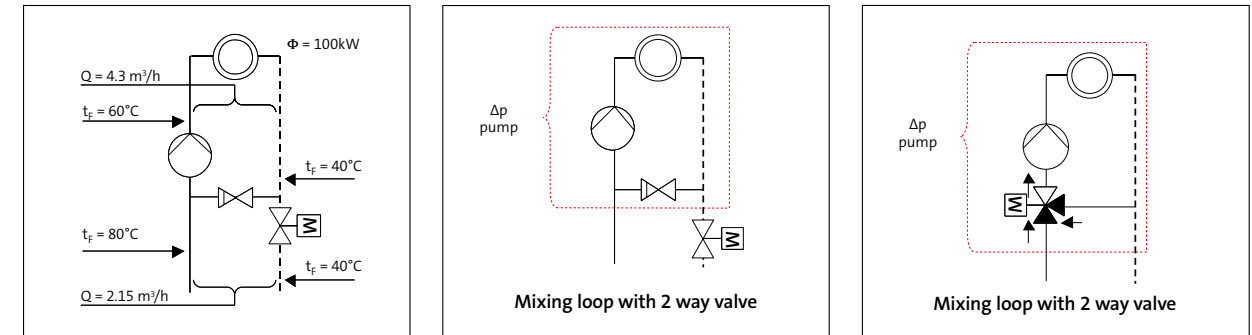

Mixing loops		Features Pumps																	Pumps							
Recommended product types: Differential pressure control	Control (depend on connected sensor)	single pump	parallel cascade operation	Relay outputs	Groundfos GO communication	RTD0 Infrared communication	BACnet MS/TP or BACnet IP communication	LONWorks data communication	PROFIBUS DP/ PROFINET data communication	Modbus RTU data communication	EtherNet/IP data communication	Modbus TCP data communication	3C/4G cellular data communication	GIC/ GRM data communication (Grundfos Remote Management) *8)	GENibus data communication	Ethernet (VNC Server) data communication	No external sensor required	Sensor (0)4-20mA / 0-10V	Sensor installed over the pump	Sensor installed in the system	Analogue setpoint influence (0-10 V)	Graphic display with user interface	Start-up wizard	Motor protection	TP	UPS
		MAGNA3	Δp,A,PP,S,F,T,P,FA	x	x	*1)	2	x	*9)	*9)	*9)	*9)	*9)	*9)	*9)	*9)	x	x	x	x	x	x	x	x	x	x
TPE series 2000	Δp	x	*2)	*3)	*4)	x	*5)	*5)	*5)	*5)	*5)	*5)	*5)					x	x	x	x	x	x	x		
TPE3 (MGE model H/I/J)	Δp,A, PP, S,F,T,P	x	x	x	2	x	*5)	*5)	*5)	*5)	*5)	*5)	*5)					x	x	x	x	x	x	x		
E-pump TPE, NBE, NKE	Δp,A,S,F,T,P,FA	x	x	*3)	*4)	x	*5)	*5)	*5)	*5)	*5)	*5)	*5)					x	x	x	x	x	x	x		
E-pump TPE,NBE,NKE (MGE model H/I/J)	Δp,A,F,T,P,FA	x	x	x	2	x	*5)	*5)	*5)	*5)	*5)	*5)	*5)					x	x	x	x	x	x	x		
Control MPC (CU352)	Δp,PP,S,F,Dt,T,P	x	x	x	2		*9)	*9)	*9)	*9)	*9)	*9)	*9)	x				x	x	x	x	x	x	x	x	x
Control MPC series 2000 (CU352)	Δp,PP,S,F,Dt,T,P	x	x	2			*9)	*9)	*9)	*9)	*9)	*9)	*9)	x				x	x	x	x	x	x	x		
CUE (Frequency converter)	Δp,PP,S,F,Dt,T,P,L	x	x	*3)	x	2		*10)	*10)	*10)	*10)	*10)	*10)	x				x	x	x	x	x	x	x	x	x
MP204 (Motorprotection)		x			1	x	x		*10)	*10)		*10)	*10)	x										x	x	x

A= Autoadapt, Dp= Differential Pressure, P= Const. Pressure, PP= Propotional Pressure, T= Const. Temperature, DT= Differential Temperature, F= Const Flow, S= Const. Speed/Frequency, L=Level, pH=pH-Wert, Cl2= Chlorine, ClO2=Chlorine dioxide, O3=Ozone, PAA=Peracitic acid, H2O2=Hydrogen peroxide , FA=FlowAdapt

- *1) MAGNA3 cascade up to 2 pumps without ext. controller
- *2) TPED
- *3) E-pumps MGE model H/I/J cascade up to 2 pumps, with external Control MPC cascade up to 6 pumps possible. Note: data point "heat energy" only on twinpump available.
- *4) All MGEs model H/I/J: 2 relays
- *5) MGE model H/I/J: CIM interfaces, TPED and MGE model F/G and TPE mod. J: CIU interfaces
- *6) version CIM xx2 needed
- *7) DDA Option E-Box Profibus
- *8) for GRM alternative solution: G501
- *9) CIM interfaces
- *10) CIU interfaces
- *11) incl. differential pressure sensor
- *12) 4-20 mA Sensor required
- x available

1.4 HEAT SURFACES

A heating surface heats the air which through the ventilation system is blown into the building. The temperature in the heating surface depends on the outdoor temperature and is controlled by way of the ventilation system's control unit. The system has a constant flow and variable temperature, where it is important that the flow is correct. Normally the flow is adjusted by a regulating valve, it may also be an advantage to use an adjustable pump (E-pump).

MAGNA3:

The pump is set to constant curve and then adjusted to the correct flow.

TPE2:

The pump is set at uncontrolled mode, and then adjusted to the correct flow.

This is easily done with remote control Grundfos GO.

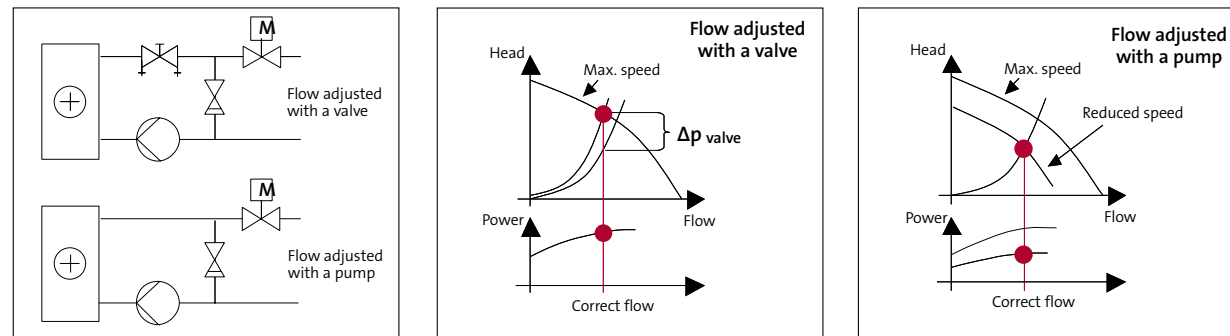

1.5 HEAT RECOVERY

Heat recovery

The purpose of the system is to recover the heat of the outlet air. The primary task of the pump is to ensure an optimal flow between the heating surfaces. The pump/valve is controlled from the general control unit of the ventilation system. The saving potential of using a controlled pump in stead of a three-way valve to reach the correct temperature is very big.

The pump is set at uncontrolled, and the signal from the central control unit is connected to the analog entry (0-10V or 0/4-20 mA).

Grundfos GO remote control must be used in connection with setting up the pump.

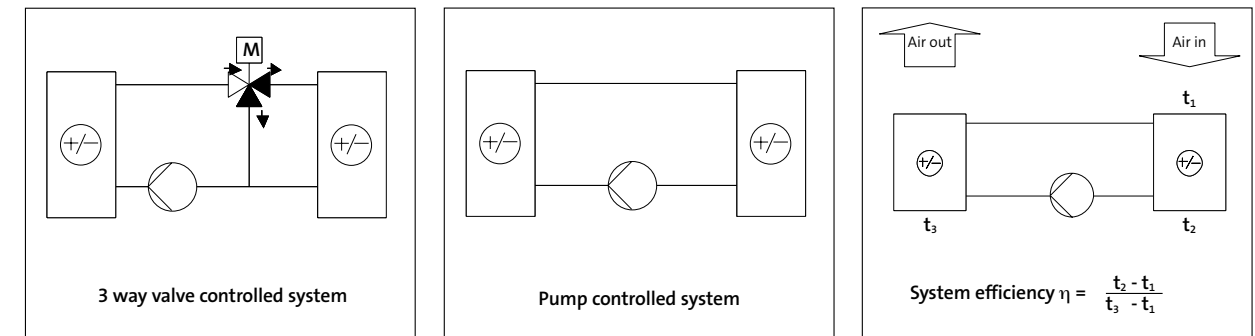

Heat surfaces		Features Pumps																	Pumps								
Recommended product types: Temperature control	Control (depend on connected sensor)	single pump	parallel cascade operation	Relay outputs	Grundfos GO communication	R100 Infrared communication	BACnet MS/TP or BACnet IP communication	LONWorks data communication	PROFIBUS DP/ PROFINET data communication	Modbus RTU data communication	EtherNet/IP data communication	Modbus TCP data communication	3G/4G cellular data communication	GiC/ GRM (Grundfos Remote Management)*8)	GENibus data communication	Ethernet (VNC Server) data communication	No external sensor required	Sensor (0)4-20mA / 0-10V	Sensor installed over the pump	Sensor installed in the system	Analogue setpoint influence (0-10 V)	Graphic display with user interface	Start-up wizard	Motor protection	TP	UPS	
		MAGNA3	Δp,A,PP,S,F,T,P,FA	x	x	*1)	2	x	*9)	*9)	*9)	*9)	*9)	*9)	*9)	*9)	*9)	x	x	x	x	x	x	x	x	x	x
E-pump TPE	Δp,A,PP,S,F,T,P,FA	x	x	*3)	*4)	x	*5)	*5)	*5)	*5)	*5)	*5)	*5)	*5)	*5)			x	x	x	x	x	x	x	x		
E-pump TPE (MGE model H/I/J)	Δp,A,PP,S,F,T,P,FA	x	x	x	2	x	*5)	*5)	*5)	*5)	*5)	*5)	*5)	*5)	*5)			x	x	x	x	x	x	x	x		
Control MPC (CU352)	Δp,PP,S,F,Dt,T,P	x	x	x	2		*9)	*9)	*9)	*9)	*9)	*9)	*9)	*9)	*9)	x		x	x	x	x	x	x	x	x	x	
Control MPC series 2000 (CU352)	Δp,PP,S,F,Dt,T,P	x	x		2		*9)	*9)	*9)	*9)	*9)	*9)	*9)	*9)	*9)	x		x	x	x	x	x	x	x	x		
CUE (Frequency converter)	Δp,PP,S,F,Dt,T,P,L	x	x	*3)	x	2		*10)	*10)	*10)	*10)	*10)	*10)	*10)	*10)	x		x	x	x	x	x	x	x	x		
MP204 (Motorprotection)		x		x	1	x		*10)	*10)		*10)	*10)	*10)	*10)	x									x	x		

A= Autoadapt, Dp= Differential Pressure, P= Const. Pressure, PP= Propotional Pressure, T= Const. Temperature, DT= Differential Temperature, F= Const Flow, S= Const. Speed/Frequency, L=Level, pH=pH-Wert, Cl2= Chlorine, ClO2=Chlorine dioxide, O3=Ozone, PAA=Peracetic acid, H2O2=Hydrogen peroxide, FA=FlowAdapt

*1) MAGNA3 cascade up to 2 pumps without ext. controller
 *2) TPED
 *3) E-pumps MGE model H/I/J cascade up to 2 pumps, with external Control MPC cascade up to 6 pumps possible. Note: data point "heat energy" only on twinpump available.
 *4) All MGEs model H/I/J: 2 relays

*5) MGE model H/I/J: CIM interfaces, TPED and MGE model F/G: CIU interfaces
 *6) version CIM xx2 needed
 *7) DDA Option E-Box Profibus
 *8) for GRM alternative solution: G501

*9) CIM interfaces
 *10) CIU interfaces
 *11) incl. differential pressure sensor
 *12) 4-20 mA Sensor required
 x available

Heat recovery		Features Pumps																	Pumps							
Recommended product types: Differential pressure control	Control (depend on connected sensor)	single pump	parallel cascade operation	Relay outputs	Grundfos GO communication	R100 Infrared communication	BACnet MS/TP or BACnet IP communication	LONWorks data communication	PROFIBUS DP/ PROFINET data communication	Modbus RTU data communication	EtherNet/IP data communication	Modbus TCP data communication	3G/4G cellular data communication	GiC/ GRM (Grundfos Remote Management)*8)	GENibus data communication	Ethernet (VNC Server) data communication	No external sensor required	Sensor (0)4-20mA / 0-10V	Sensor installed over the pump	Sensor installed in the system	Analogue setpoint influence (0-10 V)	Graphic display with user interface	Start-up wizard	Motor protection	TP	UPS
		MAGNA3	Δp,A,PP,S,F,T,P,FA	x	x	*1)	2	x	*9)	*9)	*9)	*9)	*9)	*9)	*9)	*9)	*9)	x	x	x	x	x	x	x	x	x
E-pump TPE	Δp,A,PP,S,F,T,P,FA	x	x	*3)	*4)	x	*5)	*5)	*5)	*5)	*5)	*5)	*5)	*5)	*5)			x	x	x	x	x	x	x	x	
E-pump TPE (MGE model H/I/J)	Δp,A,PP,S,F,T,P,FA	x	x	x	2	x	*5)	*5)	*5)	*5)	*5)	*5)	*5)	*5)	*5)			x	x	x	x	x	x	x	x	
Control MPC (CU352)	Δp,PP,S,F,Dt,T,P	x	x	x	2		*9)	*9)	*9)	*9)	*9)	*9)	*9)	*9)	*9)	x		x	x	x	x	x	x	x	x	
Control MPC series 2000 (CU352)	Δp,PP,S,F,Dt,T,P	x	x		2		*9)	*9)	*9)	*9)	*9)	*9)	*9)	*9)	*9)	x		x	x	x	x	x	x	x	x	
CUE (Frequency converter)	Δp,PP,S,F,Dt,T,P,L	x	x	*3)	x	2		*10)	*10)	*10)	*10)	*10)	*10)	*10)	*10)	x		x	x	x	x	x	x	x	x	
MP204 (Motorprotection)		x		x	1	x		*10)	*10)		*10)	*10)	*10)	*10)	x									x	x	

A= Autoadapt, Dp= Differential Pressure, P= Const. Pressure, PP= Propotional Pressure, T= Const. Temperature, DT= Differential Temperature, F= Const Flow, S= Const. Speed/Frequency, L=Level, pH=pH-Wert, Cl2= Chlorine, ClO2=Chlorine dioxide, O3=Ozone, PAA=Peracetic acid, H2O2=Hydrogen peroxide, FA=FlowAdapt

*1) MAGNA3 cascade up to 2 pumps without ext. controller
 *2) TPED
 *3) E-pumps MGE model H/I/J cascade up to 2 pumps, with external Control MPC cascade up to 6 pumps possible. Note: data point "heat energy" only on twinpump available.
 *4) All MGEs model H/I/J: 2 relays

*5) MGE model H/I/J: CIM interfaces, TPED and MGE model F/G: CIU interfaces
 *6) version CIM xx2 needed
 *7) DDA Option E-Box Profibus
 *8) for GRM alternative solution: G501

*9) CIM interfaces
 *10) CIU interfaces
 *11) incl. differential pressure sensor
 *12) 4-20 mA Sensor required
 x available

1.6 DHW RECIRCULATION

District hot water circulation

The purpose of the system is domestic hot water heating. The function of the circulator pump is to ensure that hot water is always available as close to the tapping point as possible, in order to reduce waste of water and increase the comfort. In certain installations (loading circuits) the pump can at the same time ensure the circulation between the inverter and the storage tank.

Normally uncontrolled pumps are used, because usually the flow variation is only small. It may be advantageous to use controlled pumps for adjustment of the flow when starting up the system, though. In large systems it will also be an advantage to use a temperature controlled pump. Because of the contents of gasses in water, it is important that this gas is not gathered in the pump, thus reducing the lifetime of the pump. Therefore it is always recommended to install the pump with upward flow direction, and minimum horizontal flow direction.

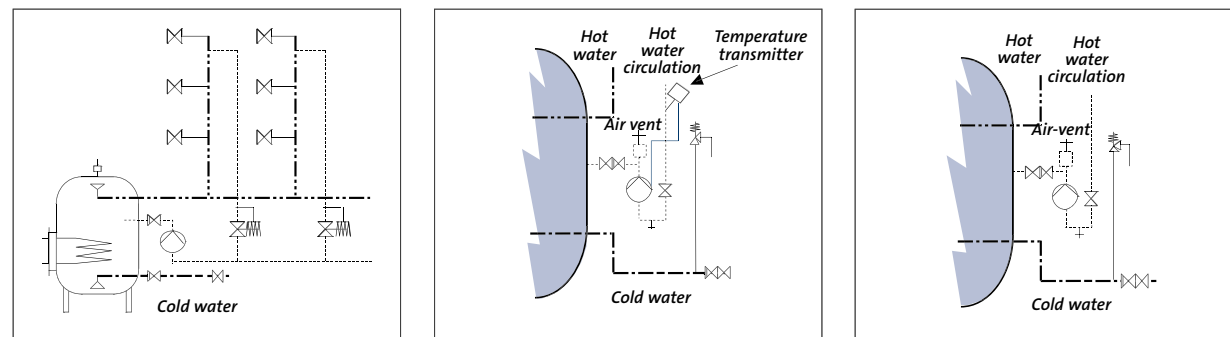

DHW recovery		Features Pumps														Pumps											
Recommended product types: Temperature control	Control (depend on connected sensor)	single pump	parallel cascade operation	Non e-pump	Relay outputs	Grundfos GO communication	R100 Infrared communication	BACnet MS/TP or BACnet IP communication	LONWorks data communication	PROFIBUS DP/ PROFINET data communication	Modbus RTU data communication	EtherNet/IP data communication	Modbus TCP data communication	3G/4G cellular data communication	CIU/ GRM (Grundfos Remote Management) *8)	GENIBUS data communication	Ethernet (VNC Server) data communication	No external sensor required	Sensor (0/4-20mA / 0-10V)	Sensor installed over the pump	Sensor installed in the system	Analogue setpoint influence (0-10 V)	Graphic display with user interface	Start-up wizard	Motor protection	TP	UPS
		MAGNA3	Δp,A,PP,S,F,T,P,FA	x	x	*1)	2	x		*9)	*9)	*9)	*9)	*9)	*9)	*9)	*9)		x	x	x	x	x	x	x	x	x
E-pump TPE	Δp,A,PP,S,F,T,P,FA	x	x	*3)	*4)	x	x	*5)	*5)	*5)	*5)	*5)	*5)	*5)	*5)		x	x	x	x							
E-pump TPE (MGE model H/I/J)	Δp,A,PP,S,F,T,P,FA	x	x	x	*3)	2	x	*5)	*5)	*5)	*5)	*5)	*5)	*5)	*5)		x	x	x	x	x	x	x	x	x		
Control MPC (CU352)	Δp,PP,S,F,Dt,T,P	x	x	x	2	x		*9)	*9)	*9)	*9)	*9)	*9)	*9)	*9)		x	x	x	x	x	x	x	x	x	x	
Control MPC series 2000 (CU352)	Δp,PP,S,F,Dt,T,P	x	x		2			*9)	*9)	*9)	*9)	*9)	*9)	*9)	*9)		x	x	x	x	x	x	x	x	x		
CUE (Frequency converter)	Δp,PP,S,F,Dt,T,P,L	x	x	*3)	x	2		*10)	*10)	*10)	*10)	*10)	*10)	*10)	*10)		x	x	x	x	x	x	x	x	x	x	
MP204 (Motorprotection)		x			1	x	x		*10)	*10)	*10)	*10)	*10)	*10)	*10)		x								x	x	

A= Autoadapt, Δp= Differential Pressure, P= Const. Pressure, PP= Propotional Pressure, T= Const. Temperature, Dt= Differential Temperature, F= Const Flow, S= Const. Speed/Frequency, L=Level, pH=pH-Wert, Cl2= Chlorine, ClO2=Chlorine dioxide, O3=Ozone, PAA=Peracetic acid, H2O2=Hydrogen peroxide, FA=FlowAdapt

*1) MAGNA3 cascade up to 2 pumps without ext. controller
 *2) TPED
 *3) E-pumps MGE model H/I/J cascade up to 2 pumps, with external Control MPC cascade up to 6 pumps possible. Note: data point "heat energy" only on twinpump available.
 *4) All MGEs model H/I/J: 2 relays

*5) MGE model H/I/J: CIM interfaces, TPED and MGE model F/G: CIU interfaces
 *6) version CIM xx2 needed
 *7) DDA Option E-Box Profibus
 *8) for GRM alternative solution: G501

*9) CIM interfaces
 *10) CIU interfaces
 *11) incl. differential pressure sensor
 *12) 4-20 mA Sensor required
 x available

1.7 DHW PRODUCTION

District hot water production

To make the system as flexible as possible, the heating and storage of the domestic hot water are divided into two units, one for heating and one for accumulation of the hot water. The construction of the systems among others depends on the kind of heat exchanger (charger) used. The pump is controlled by the temperature in the storage tank, either ON/OFF or variable speed.

If one pump is used for both accumulation and circulation, the minimum flow of the pump must be the same as the required flow for circulation. If the pump is installed on the "hot" side of the exchanger, it must be ensured that the temperature does not exceed required max. temperature, as this may cause lime depositing in the pump. Because of the contents of gasses in the water, it is important that this gas is not gathered in the pump.

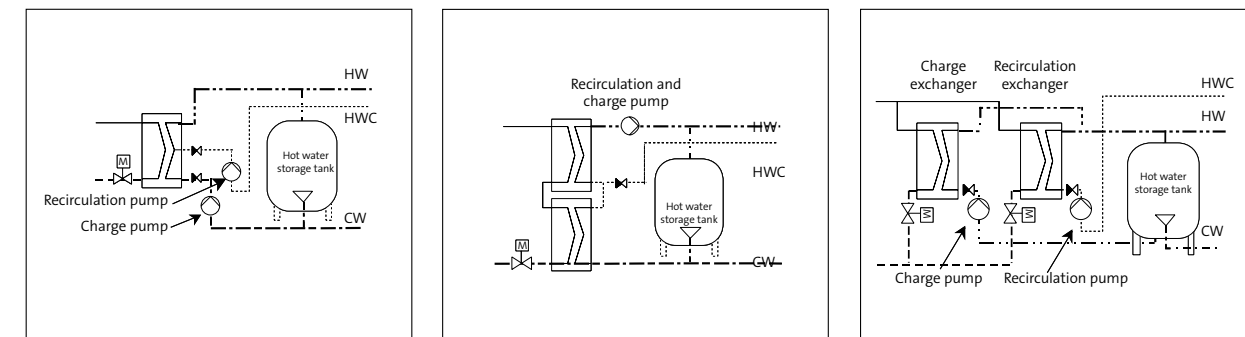

DHW production		Features Pumps														Pumps											
Recommended product types: Temperature control	Control (depend on connected sensor)	single pump	parallel cascade operation	Non e-pump	Relay outputs	Grundfos GO communication	R100 Infrared communication	BACnet MS/TP or BACnet IP communication	LONWorks data communication	PROFIBUS DP/ PROFINET data communication	Modbus RTU data communication	EtherNet/IP data communication	Modbus TCP data communication	3G/4G cellular data communication	CIU/ GRM (Grundfos Remote Management) *8)	GENIBUS data communication	Ethernet (VNC Server) data communication	No external sensor required	Sensor (0/4-20mA / 0-10V)	Sensor installed over the pump	Sensor installed in the system	Analogue setpoint influence (0-10 V)	Graphic display with user interface	Start-up wizard	Motor protection	TP	UPS
		MAGNA3	Δp,A,PP,S,F,T,P,FA	x	x	*1)	2	x		*9)	*9)	*9)	*9)	*9)	*9)	*9)	*9)		x	x	x	x	x	x	x	x	x
E-pump TPE	Δp,A,PP,S,F,T,P,FA	x	x	*3)	*4)	x	x	*5)	*5)	*5)	*5)	*5)	*5)	*5)	*5)		x	x	x	x							
E-pump TPE (MGE model H/I/J)	Δp,A,PP,S,F,T,P,FA	x	x	x	*3)	2	x	*5)	*5)	*5)	*5)	*5)	*5)	*5)	*5)		x	x	x	x	x	x	x	x	x		
Control MPC (CU352)	Δp,PP,S,F,Dt,T,P	x	x	x	2	x		*9)	*9)	*9)	*9)	*9)	*9)	*9)	*9)		x	x	x	x	x	x	x	x	x	x	
Control MPC series 2000 (CU352)	Δp,PP,S,F,Dt,T,P	x	x		2			*9)	*9)	*9)	*9)	*9)	*9)	*9)	*9)		x	x	x	x	x	x	x	x	x		
CUE (Frequency converter)	Δp,PP,S,F,Dt,T,P,L	x	x	*3)	x	2		*10)	*10)	*10)	*10)	*10)	*10)	*10)	*10)		x	x	x	x	x	x	x	x	x	x	
MP204 (Motorprotection)		x			1	x	x		*10)	*10)	*10)	*10)	*10)	*10)	*10)		x								x	x	

A= Autoadapt, Δp= Differential Pressure, P= Const. Pressure, PP= Propotional Pressure, T= Const. Temperature, Dt= Differential Temperature, F= Const Flow, S= Const. Speed/Frequency, L=Level, pH=pH-Wert, Cl2= Chlorine, ClO2=Chlorine dioxide, O3=Ozone, PAA=Peracetic acid, H2O2=Hydrogen peroxide, FA=FlowAdapt

*1) MAGNA3 cascade up to 2 pumps without ext. controller
 *2) TPED
 *3) E-pumps MGE model H/I/J cascade up to 2 pumps, with external Control MPC cascade up to 6 pumps possible. Note: data point "heat energy" only on twinpump available.
 *4) All MGEs model H/I/J: 2 relays

*5) MGE model H/I/J: CIM interfaces, TPED and MGE model F/G: CIU interfaces
 *6) version CIM xx2 needed
 *7) DDA Option E-Box Profibus
 *8) for GRM alternative solution: G501

*9) CIM interfaces
 *10) CIU interfaces
 *11) incl. differential pressure sensor
 *12) 4-20 mA Sensor required
 x available

2. DISTRICT HEATING

CAMPUS/ LARGE SCALE DH

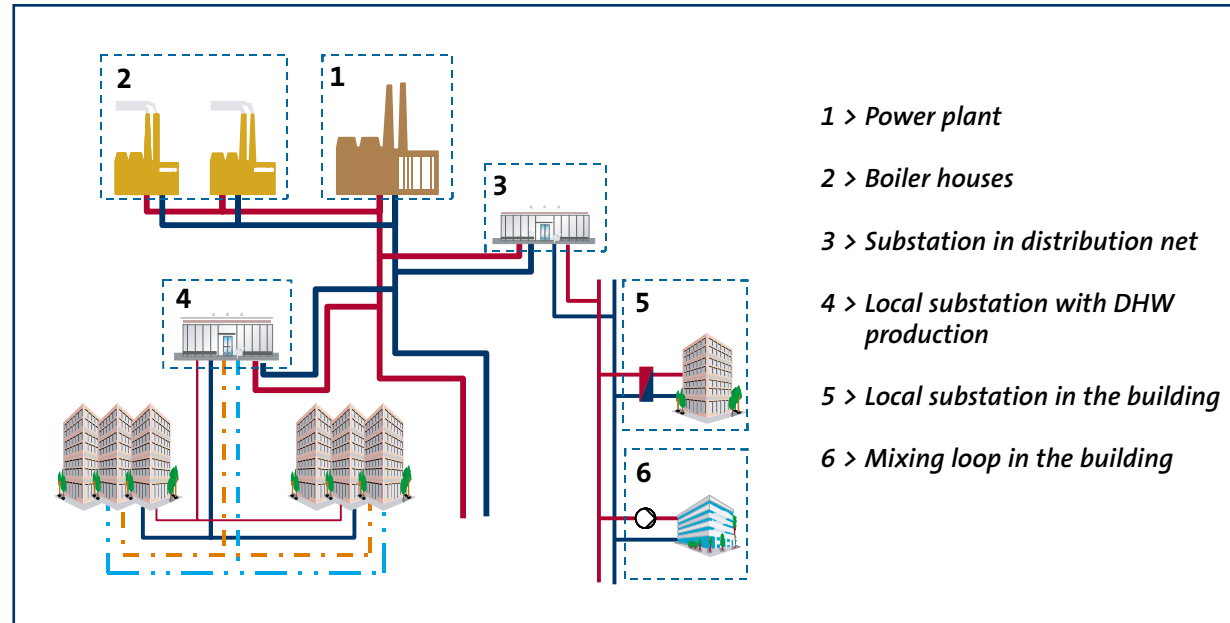

District heating describes a water-based heating system where there is a considerable distance between the place the heat is generated (power plant) and the place the heat is used (the building).

District heating has become more and more popular all over the world, and is found in the majority of larger cities.

At the power plants, flue gas undergoes an exceptionally advanced treatment before being released. This has become an important factor in improving air quality in cities.

A district heating system consists of:
 a generation system (power plant)
 a distribution system (underground pipes)
 a user solution (individual heating system at the user)
 The heat is traditionally produced at the power plants, where fossil fuel (coal, oil, etc) or alternative fuels (straw, wood chips, etc) is burned. A few power plants also have solar energy systems.

Heat generation is often combined with the generation of electricity in the same power plant.

From the power plant, the heat is sent through transmission piping to heat exchanger substations. The heat is traditionally distributed between the power plant and the heat exchanger substation at a flow temperature of up to 120°C.

In the heat exchanger substation, it is usually exchanged down to around 90°C. The heat is then transferred through the distribution system (pipes) to the users.

One of the drawbacks with district heating is that the long distances between the power plant and user causes relatively large heat losses.

Connection to district heating can take place either directly or through an indirect system



2.1 MAIN PUMPS

Main Pumps

Due to variations in heating demand and flow, we recommend that the main pumps be speedregulated and installed in parallel. Install a maximum of 3 pumps plus 1 as a standby. The use of speed-regulated pumps maximises the potential energy saving.

It is important to check the efficiency at the duty point at which the system has a high number of operating hours.

Using MAGNA3 and TPE3 pumps no external pressure sensor or motor protection is necessary. A ControlMPC is needed for parallel operation of 3 or more pumps. It is possible to have proportional pressure without a sensor placed in the system. For pumps above 22 kW an external sensor, motor protection and a pump control unit are necessary.

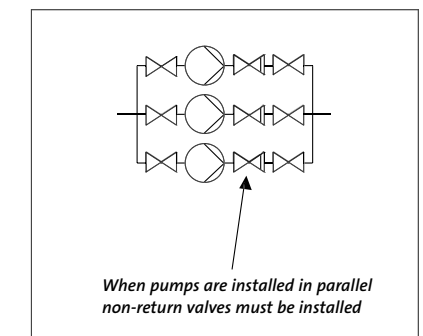
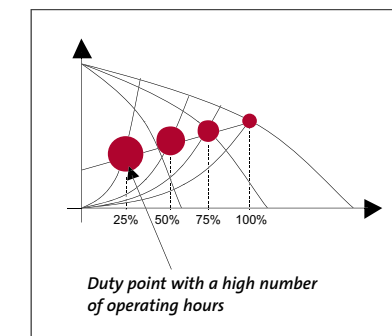
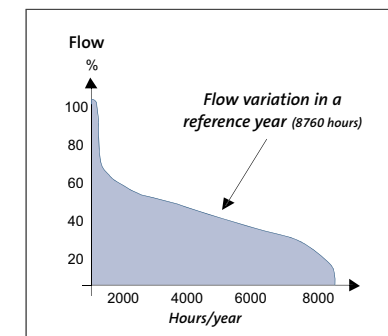

Recommended product types: Differential pressure control	Control (depend on connected sensor)	Features Pumps														Pumps										
		single pump duty / standby	parallel cascade operation	Non e-pump Relay outputs	Grundfos GO communication	RIO0 infrared communication	BACnet MS/TP or BACnet IP communication	LONWorks data communication	PROFIBUS DP/ PROFINET data communication	Modbus RTU data communication	EtherNet/IP data communication	Modbus TCP data communication	3G/4G cellular data communication	GiC / GRM (Grundfos Remote Management)	GENibus data communication	Ethernet (VNC Server) data communication	No external sensor required	Sensor (0)4-20mA / 0-10V	Sensor installed over the pump	Sensor installed in the system	Analogue setpoint influence (0-10 V)	Graphic display with user interface	Start-up wizard	Motor protection	TP	NB, NK
MAGNA3	Δp,A,PP,S,F,T,P,FA	x	x	*1)	2	x	*9)	*9)	*9)	*9)	*9)	*9)	*9)	*9)	x	x	x	x	x	x	x	x	x	x		
TPE series 2000	Δp	x	*2)	*3)	*4)	x	x	*5)	*5)	*5)	*5)	*5)	*5)	*5)		*11)	*11)									
TPE3 (MGE model H/I/J)	Δp,A,PP,S,T,P	x	x	x	2	x	x	*5)	*5)	*5)	*5)	*5)	*5)	*5)		*11)	*11)			x	x	x	x	x		
E-pump TPE, NBE, NKE	Δp,A,S,F,T,P,FA	x	x	*3)	*4)	x	x	*5)	*5)	*5)	*5)	*5)	*5)	*5)			x	x	x	x				x		
E-pump TPE,NBE,NKE (MGE model H/I/J)	Δp,A,F,T,P,FA	x	x	x	2	x		*5)	*5)	*5)	*5)	*5)	*5)	*5)			x	x	x	x	x	x	x	x		
Control MPC (CU352)	Δp,PP,S,F,Dt,T,P	x	x	x	2		x	*5)	*9)	*9)	*9)	*9)	*9)	*9)	x	x			x	x	x	x	x	x	x	x
Control MPC series 2000 (CU352)	Δp,PP,S,F,Dt,T,P	x	x		2			*9)	*9)	*9)	*9)	*9)	*9)	*9)	x	x			x	x	x	x	x	x	x	x
CUE (Frequency converter)	Δp,PP,S,F,Dt,T,P,L	x	x	*3)	x	2		*10)	*10)	*10)	*10)	*10)	*10)	*10)	x		x	x	x	x	x	x	x	x	x	x
MP204 (Motorprotection)		x			x	1	x	x			*10)	*10)	*10)	*10)	x									x	x	x

A= Autoadapt, Dp= Differential Pressure, P= Const. Pressure, PP= Proportional Pressure, T= Const. Temperature, Dt= Differential Temperature, F= Const Flow, S= Const. Speed/Frequency, L=Level, pH=pH-Wert, Cl2= Chlorine, ClO2=Chlorine dioxide, O3=Ozone, PAA=Peracetic acid, H2O2=Hydrogen peroxide, FA=FlowAdapt

*1) MAGNA3 cascade up to 2 pumps without ext. controller
 *2) TPED
 *3) with external Control MPC/ E-pumps with MGE Model H/I/J can cascade up to 4 pumps (data point heat energy only on twinpump)
 *4) All MGEs model H/I/J: 2 relays
 *5) MGE model H/I/J: CIM interfaces, TPED and MGE model F/G and TPE mod. J: CIU interfaces
 *6) version CIM xx2 needed
 *7) DDA Option E-Box Profibus
 *8) for GRM alternative solution: G501
 *9) CIM interfaces
 *10) CIU interfaces
 *11) incl. differential pressure sensor
 *12) 4-20 mA Sensor required x available

2.2 BOOSTER PUMPS

In Instead of using a large closed pressure tank, one or more pumps together with an open storage tank will maintain constant static pressure in the system. If the system pressure exceeds the allowable level, a relief valve will lead the water back to the tank. It is recommended that treated water be used.

It is recommendable always to install a standby pump. If the system is used for refilling the system please note that there is a risk of cavitation in the pump when the system pressure is very low. To avoid this the flow from the pump has to be throttled down.

The set point will be the static pressure of the system.

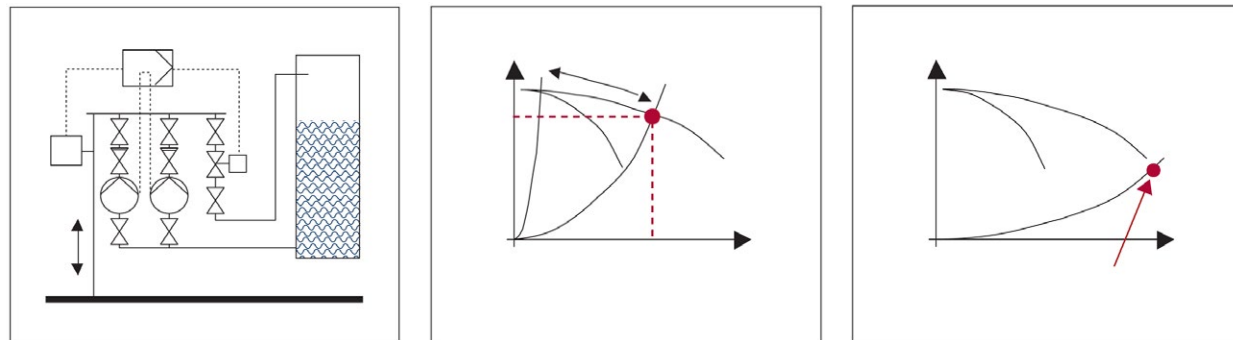

2.3.DISTRIBUTED PUMPS

Due to variations in the use and heat demand in different parts of the buildings, the system is divided into zones controlled by a mixing loop. The flow temperature is lower than in the mains supply, and this results in a higher flow in the zones than in the mains supply. As a result a better hydraulic balance is achieved in the system as a whole.

Speed regulated pumps maximise energy savings.

New designs size the pipes in a way that no bypass, no three way valves are needed, just simple circulators on secondary side. and main pumps on primary side.

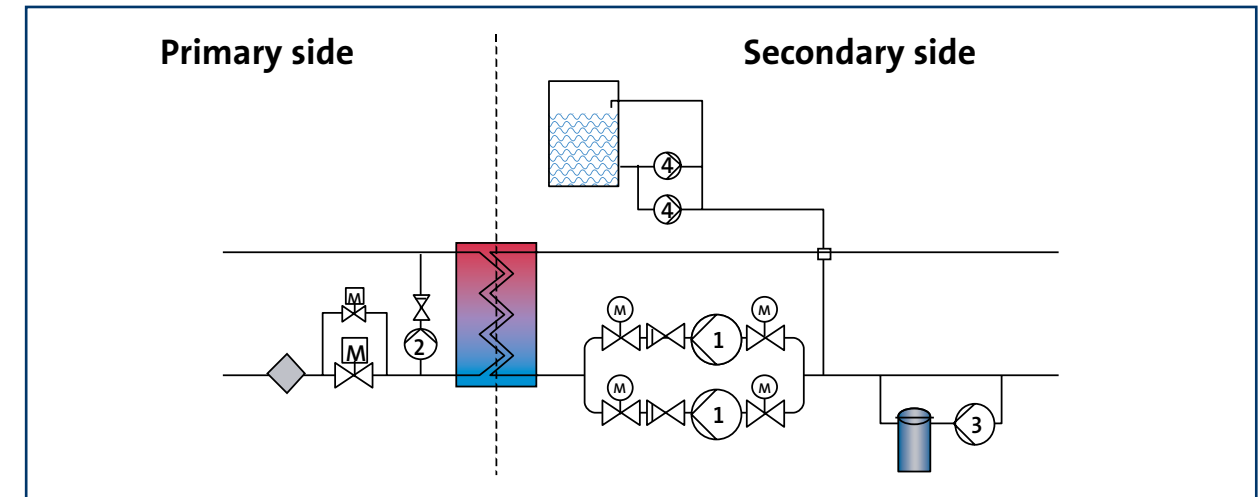

Booster pumps		Features Pumps																Pumps									
Recommended product types: Pressure control, Differential pressure control	Control (depend on connected sensor)	single pump	parallel cascade operation	Non e-pump	Relay outputs	Grundfos GO communication	R100 Infrared communication	BACnet MS/TP or BACnet IP communication	LONWorks data communication	PROFIBUS DP/ PROFINET data communication	Modbus RTU data communication	EtherNet/IP data communication	Modbus TCP data communication	3G/4G cellular data communication	GiC/ GRM (Grundfos Remote Management) *8)	GENIBus data communication	Ethernet (VNC Server) data communication	No external sensor required	Sensor (0)4-20mA / 0-10V	Sensor installed over the pump	Sensor installed in the system	Analogue setpoint influence (0-10 V)	Grafic display with user interface	Start-up wizard	Motor protection	CR	CM
		E-pump CRE	P	x	x	*3)	*4)	x	x	*5)	*5)	*5)	*5)	*5)	*5)	*5)	*5)	*5)	x	x	x	x	x	x	x	x	x
E-pump CRE (MGE model H/I/J)	P	x	x	x	*3)	2	x	x	*5)	*5)	*5)	*5)	*5)	*5)	*5)		x	x	x	x	x	x	x	x	x		
Control MPC (CU352)	$\Delta p, PP, S, F, Dt, T, P$	x	x	x	2				*9)	*9)	*9)	*9)	*9)	*9)	*9)	x	x	x	x	x	x	x	x	x	x	x	x
Control MPC series 2000 (CU352)	$\Delta p, PP, S, F, Dt, T, P$	x	x		2				*9)	*9)	*9)	*9)	*9)	*9)	*9)	x	x	x	x	x	x	x	x	x	x		
HydroMPC (CU352)	P	x	x		2				*9)	*9)	*9)	*9)	*9)	*9)	*9)	x	x	x	x	x	x	x	x	x	x	x	x
CUE (Frequency converter)	$\Delta p, PP, S, F, Dt, T, P, L$	x	x	*3)	x	2			*10)	*10)	*10)	*10)	*10)	*10)	*10)	x	x	x	x	x	x	x	x	x	x	x	x
MP204 (Motorprotection)		x			x	1	x	x		*10)	*10)					x									x	x	x

A= Autoadapt, Dp= Differential Pressure, P= Const. Pressure, PP= Proportional Pressure, T= Const. Temperature, DT= Differential Temperature, F= Const Flow, S= Const. Speed/Frequency, L=Level, pH=pH-Wert, Cl2= Chlorine, ClO2=Chlorine dioxide, O3=Ozone, PAA=Peracetic acid, H2O2=Hydrogen peroxide, FA=FlowAdapt

*1) MAGNA3 cascade up to 2 pumps without ext. controller
 *2) TPED
 *3) E-pumps MGE model H/I/J cascade up to 2 pumps, with external Control MPC cascade up to 6 pumps possible. Note: data point "heat energy" only on twinpump available.

*4) All MGEs model H/I/J: 2 relays
 *5) MGE model H/I/J: CIM interfaces, TPED and MGE model F/G: CIU interfaces
 *6) version CIM xx2 needed
 *7) DDA Option E-Box Profibus

*8) for GRM alternative solution: G501
 *9) CIM interfaces
 *10) CIU interfaces
 *11) incl. differential pressure sensor
 *12) 4-20 mA Sensor required x available

Distributed pumps		Features Pumps																Pumps									
Recommended product types: Temperature control	Control (depend on connected sensor)	single pump	parallel cascade operation	Non e-pump	Relay outputs	Grundfos GO communication	R100 Infrared communication	BACnet MS/TP or BACnet IP communication	LONWorks data communication	PROFIBUS DP/ PROFINET data communication	Modbus RTU data communication	EtherNet/IP data communication	Modbus TCP data communication	3G/4G cellular data communication	GiC/ GRM (Grundfos Remote Management) *8)	GENIBus data communication	Ethernet (VNC Server) data communication	No external sensor required	Sensor (0)4-20mA / 0-10V	Sensor installed over the pump	Sensor installed in the system	Analogue setpoint influence (0-10 V)	Grafic display with user interface	Start-up wizard	Motor protection	TP	NB, NK
		E-pump TPE, NBE, NKE	$\Delta p, A, PP, S, F, T, P, FA$	x	x	*3)	*4)	x	x	*5)	*5)	*5)	*5)	*5)	*5)	*5)	*5)	*5)			x	x	x	x	x	x	x
E-pump TPE, NBE, NKE (MGE model H/I/J)	$\Delta p, A, S, F, T, P, FA$	x	x	x	*3)	2	x	x	*5)	*5)	*5)	*5)	*5)	*5)	*5)			x	x	x	x	x	x	x	x		
Control MPC (CU352)	$\Delta p, PP, S, F, Dt, T, P$	x	x	x	2				*9)	*9)	*9)	*9)	*9)	*9)	*9)	x	x	x	x	x	x	x	x	x	x	x	x
Control MPC series 2000 (CU352)	$\Delta p, PP, S, F, Dt, T, P$	x	x		2				*9)	*9)	*9)	*9)	*9)	*9)	*9)	x	x	x	x	x	x	x	x	x	x		
CUE (Frequency converter)	$\Delta p, PP, S, F, Dt, T, P, L$	x	x	*3)	x	2			*10)	*10)	*10)	*10)	*10)	*10)	*10)	x			x	x	x	x	x	x	x	x	x
MP204 (Motorprotection)		x			x	1	x	x		*10)	*10)					x									x	x	x

A= Autoadapt, Dp= Differential Pressure, P= Const. Pressure, PP= Proportional Pressure, T= Const. Temperature, DT= Differential Temperature, F= Const Flow, S= Const. Speed/Frequency, L=Level, pH=pH-Wert, Cl2= Chlorine, ClO2=Chlorine dioxide, O3=Ozone, PAA=Peracetic acid, H2O2=Hydrogen peroxide, FA=FlowAdapt

*1) MAGNA3 cascade up to 2 pumps without ext. controller
 *2) TPED
 *3) E-pumps MGE model H/I/J cascade up to 2 pumps, with external Control MPC cascade up to 6 pumps possible. Note: data point "heat energy" only on twinpump available.

*4) All MGEs model H/I/J: 2 relays
 *5) MGE model H/I/J: CIM interfaces, TPED and MGE model F/G: CIU interfaces
 *6) version CIM xx2 needed
 *7) DDA Option E-Box Profibus

*8) for GRM alternative solution: G501
 *9) CIM interfaces
 *10) CIU interfaces
 *11) incl. differential pressure sensor
 *12) 4-20 mA Sensor required x available

2.8 TEMPERATURE SHUNT PUMPS

Temperature shunt pumps

A temperature shunt must ensure a constant temperature at the top of the heat exchanger to avoid tension on the material and to minimize the risk of leakage. The correct temperature depends on the heat exchanger.

TPE: The pumps have an integrated frequency converter and motor protection.
 A temperature transmitter with an output signal of 0/5-10V or 0/4-20 mA should be used. Grundfos GO remote control is used for start-up and later for extracting operating data.
 TP/NK: These pump types require an external frequency converter and an external regulator.

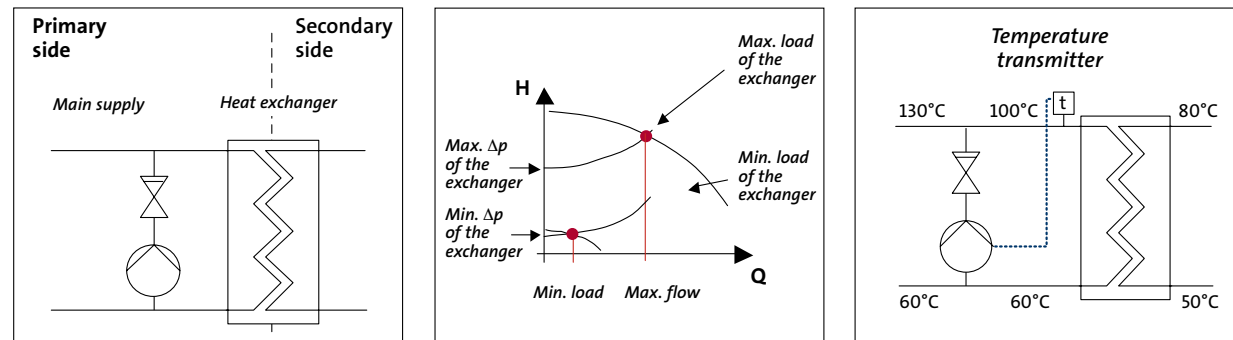

2.9 MIXING LOOP PUMPS

Mixing loops

Due to variations in the use and heat demand in different parts of the building, the system is divided into zones controlled by a mixing loop. The flow temperature is lower than in the mains supply, and this results in a higher flow in the zones than in the mains supply. As a result a better hydraulic balance is achieved in the system as a whole. Speedregulated pumps maximise energy savings.

When using a two-way valve, the pressure lost in the valve will be managed by the main pump. When using a three-way valve, the pump in the mixing loop also has to manage the pressure lost in the valve. With MAGNA3 and TPE3 pumps there is no need for an external pressure sensor or motor protection. It is possible "to have proportional pressure without having a sensor in the system."

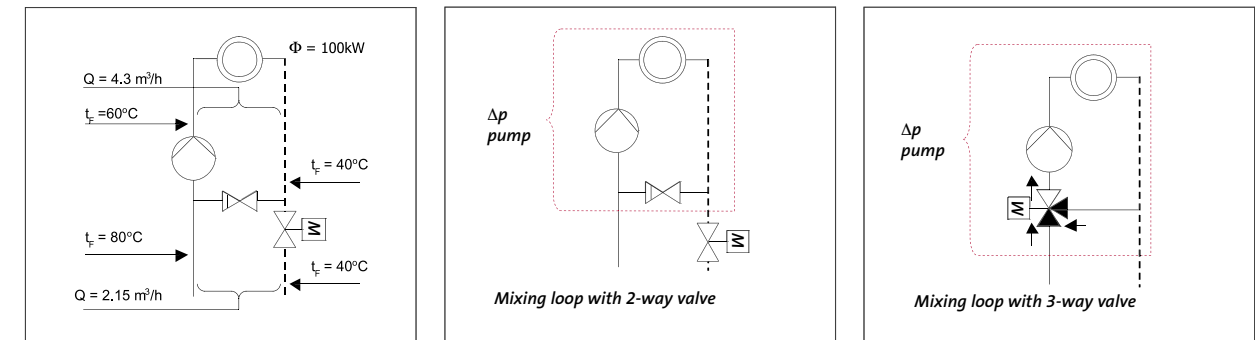

Temperature shunt pumps		Features Pumps														Pumps											
Recommended product types: Temperature control	Control (depend on connected sensor)	single pump duty / standby	parallel cascade operation	Non e-pump	Relay outputs	Grundfos GO communication	R100 Infrared communication	BACnet MS/TP or BACnet IP communication	LONWorks data communication	PROFIBUS DP/ PROFINET data communication	Modbus RTU data communication	EtherNet/IP data communication	Modbus TCP data communication	3G/4G cellular data communication	CIU/ GRM (Grundfos Remote Management) *8)	GENIbus data communication	Ethernet (VNC Server) data communication	No external sensor required	Sensor (0/4-20mA / 0-10V)	Sensor installed over the pump	Sensor installed in the system	Analogue setpoint influence (0-10 V)	Grafic display with user interface	Start-up wizard	Motor protection	TP	NB; NK
		E-pump TPE, NBE, NKE	Δp,A,S,F,T,P,FA	x	x	*3)	*4)	x	x	*5)	*5)	*5)	*5)	*5)	*5)	*5)	*5)	x	x	x	x	x	x	x	x	x	x
E-pump TPE,NBE,NKE (MGE model H/I/J)	Δp,A,S,F,T,P,FA	x	x	x	*3)	2	x	x	*5)	*5)	*5)	*5)	*5)	*5)	*5)	x	x	x	x	x	x	x	x	x	x	x	
CUE (Frequency converter)	Δp,PP,S,F,Dt,T,P,L	x	x	*3)	x	2			*10)	*10)	*10)	*10)	*10)	*10)	x				x	x	x	x	x	x	x	x	
MP204 (Motorprotection)		x			x	1	x	x			*10)	*10)	*10)	*10)	x										x	x	x

A= Autoadapt, Dp= Differential Pressure, P= Const. Pressure, PP= Proportional Pressure, T= Const. Temperature, Dt= Differential Temperature, F= Const Flow, S= Const. Speed/Frequency, L=Level, pH=pH-Wert, Cl2= Chlorine, ClO2=Chlorine dioxide, O3=Ozone, PAA=Peracetic acid, H2O2=Hydrogen peroxide, FA=FlowAdapt

- *1) MAGNA3 cascade up to 2 pumps without ext. controller
- *2) TPED
- *3) E-pumps MGE model H/I/J cascade up to 2 pumps, with external Control MPC cascade up to 6 pumps possible. Note: data point "heat energy" only on twinpump available.
- *4) All MGEs model H/I/J: 2 relays
- *5) MGE model H/I/J: CIM interfaces, TPED and MGE model F/G: CIU interfaces
- *6) version CIM xx2 needed
- *7) DDA Option E-Box Profibus
- *8) for GRM alternative solution: G501
- *9) CIM interfaces
- *10) CIU interfaces
- *11) incl. differential pressure sensor
- *12) 4-20 mA Sensor required x available

Mixing loop pumps		Features Pumps														Pumps											
Recommended product types: Differential pressure control	Control (depend on connected sensor)	single pump duty / standby	parallel cascade operation	Non e-pump	Relay outputs	Grundfos GO communication	R100 Infrared communication	BACnet MS/TP or BACnet IP communication	LONWorks data communication	PROFIBUS DP/ PROFINET data communication	Modbus RTU data communication	EtherNet/IP data communication	Modbus TCP data communication	3G/4G cellular data communication	CIU/ GRM (Grundfos Remote Management) *8)	GENIbus data communication	Ethernet (VNC Server) data communication	No external sensor required	Sensor (0/4-20mA / 0-10V)	Sensor installed over the pump	Sensor installed in the system	Analogue setpoint influence (0-10 V)	Grafic display with user interface	Start-up wizard	Motor protection	TP	NB
		MAGNA3	Dp,A,PP,S,F,T,P,FA	x	x	*1)	2	x		*9)	*9)	*9)	*9)	*9)	*9)	*9)	*9)	x	x	x	x	x	x	x	x	x	x
TPE series 2000	Dp	x	x	*2)	*3)	*4)	x	x	*5)	*5)	*5)	*5)	*5)	*5)	*5)				*11)	*11)	x	x	x	x	x	x	
TPE3 (MGE model H/I/J)	Dp	x	x	x	*3)	2	x	x	*5)	*5)	*5)	*5)	*5)	*5)	*5)				*11)	*11)	x	x	x	x	x	x	
E-pump TPE, NBE, NKE	Dp,A,S,F,T,P,FA	x	x	*3)	*4)	x	x	*5)	*5)	*5)	*5)	*5)	*5)	*5)	*5)	x	x	x	x	x	x	x	x	x	x	x	
E-pump TPE,NBE,NKE (MGE model H/I/J)	Dp,A,S,F,T,P,FA	x	x	x	*3)	2	x	x	*5)	*5)	*5)	*5)	*5)	*5)	*5)	x	x	x	x	x	x	x	x	x	x	x	
CUE (Frequency converter)	Dp,PP,S,F,Dt,T,P,L	x	x	*3)	x	2			*10)	*10)	*10)	*10)	*10)	*10)	*10)	x			x	x	x	x	x	x	x	x	
MP204 (Motorprotection)		x			x	1	x	x			*10)	*10)	*10)	*10)	x										x	x	x

A= Autoadapt, Dp= Differential Pressure, P= Const. Pressure, PP= Proportional Pressure, T= Const. Temperature, Dt= Differential Temperature, F= Const Flow, S= Const. Speed/Frequency, L=Level, pH=pH-Wert, Cl2= Chlorine, ClO2=Chlorine dioxide, O3=Ozone, PAA=Peracetic acid, H2O2=Hydrogen peroxide, FA=FlowAdapt

- *1) MAGNA3 cascade up to 2 pumps without ext. controller
- *2) TPED
- *3) E-pumps MGE model H/I/J cascade up to 2 pumps, with external Control MPC cascade up to 6 pumps possible. Note: data point "heat energy" only on twinpump available.
- *4) All MGEs model H/I/J: 2 relays
- *5) MGE model H/I/J: CIM interfaces, TPED and MGE model F/G and TPE mod. J: CIU interfaces
- *6) version CIM xx2 needed
- *7) DDA Option E-Box Profibus
- *8) for GRM alternative solution: G501
- *9) CIM interfaces
- *10) CIU interfaces
- *11) incl. differential pressure sensor
- *12) 4-20 mA Sensor required x available

2.10 CIRCULATION PUMPS

DHW recirculation

The purpose of the system is to heat domestic hot water. The function of the circulator pump is to ensure that hot water is always available as close to the tapping point as possible in order to reduce wastage and increase comfort. In certain installations (loading circuits) the pump can at the same time ensure circulation between the inverter and the storage tank.

Unregulated pumps are normally used because the variations in flow are usually only small. However, it may be advantageous to use regulated pumps to adjust the flow when starting up the system.

In large systems it will also be an advantage to use a temperature-regulated pump. Because of the gas content in water, it is recommended that the pump always be installed with an upward flow direction and a minimal horizontal flow direction. It is important that gas does not collect in the pump as this reduces its lifetime.

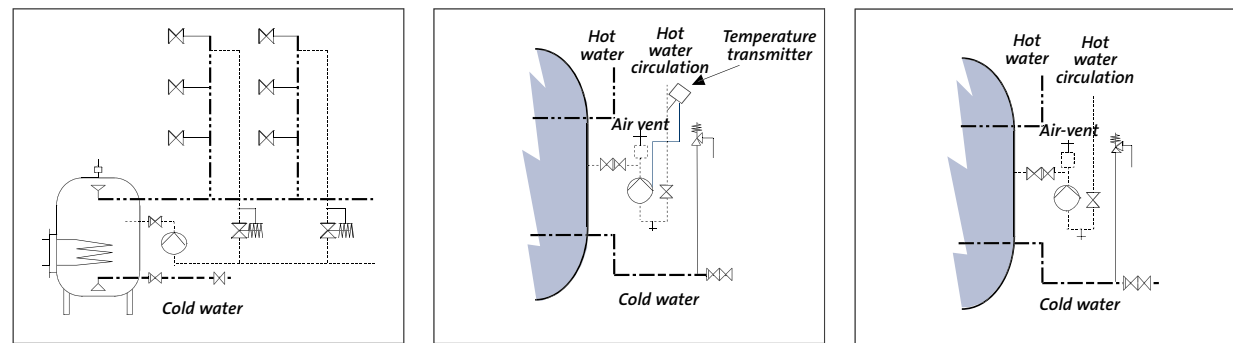

2.10.B CHARGE PUMPS

District hot water production

To make the system as flexible as possible, the heating and storage of the domestic hot water are divided into two units, one for heating and one for accumulation of the hot water. The construction of the systems among others depends on the kind of heat exchanger (charger) used. The pump is controlled by the temperature in the storage tank, either ON/OFF or variable speed.

If one pump is used for both accumulation and circulation, the minimum flow of the pump must be the same as the required flow for circulation. If the pump is installed on the "hot" side of the exchanger, it must be ensured that the temperature does not exceed required max. temperature, as this may cause lime depositing in the pump. Because of the contents of gasses

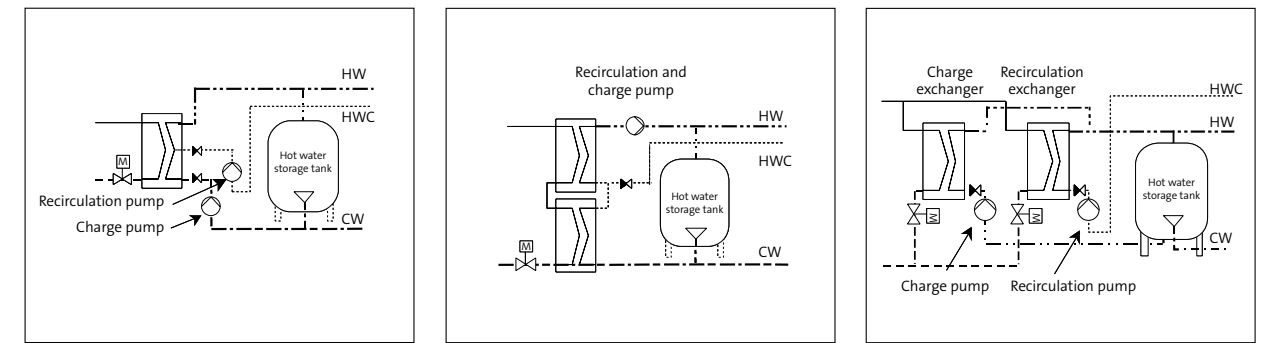

DHW pumps		Features Pumps														Pumps										
Recommended product types: Pressure control	Control (depend on connected sensor)	single pump	parallel cascade operation	Relay outputs	Grundfos GO communication	RT00 Infrared communication	BACnet MS/TP or BACnet IP communication	LONWorks data communication	EtherNet/IP data communication	Modbus TCP data communication	PROFIBUS DP/ PROFINET data communication	Modbus RTU data communication	3G/4G cellular data communication	GIC/ GRM (Grundfos Remote Management) *8)	GENIBUS data communication	Ethernet (VNC Server) data communication	No external sensor required	Sensor (0/4-20mA / 0-10V)	Sensor installed over the pump	Sensor installed in the system	Analogue setpoint influence (0-10 V)	Grafic display with user interface	Start-up wizard	Motor protection	TP	NB
		E-pump CRE, NBE, NKE	Δp,A,S,F,T,P,FA	x	x	*3)	*4)	x	x	*5)	*5)	*5)	*5)	*5)	*5)	*5)	*5)		x	x	x	x	x	x	x	x
E-pump CRE,NBE,NKE (MGE model H/I/J)	Δp,A,S,F,T,P,FA	x	x	x	*3)	2	x	x	*5)	*5)	*5)	*5)	*5)	*5)	*5)		x	x	x	x	x	x	x	x		
Control MPC (CU352)	Δp,PP,S,F,Dt,T,P	x	x	x	2				*9)	*9)	*9)	*9)	*9)	*9)	*9)	x		x	x	x	x	x	x	x		
Control MPC series 2000 (CU352)	Δp,PP,S,F,Dt,T,P	x	x		2				*9)	*9)	*9)	*9)	*9)	*9)	*9)	x		x	x	x	x	x	x	x		
CUE (Frequency converter)	Δp,PP,S,F,Dt,T,P,L	x	x	*3)	2				*10)	*10)	*10)	*10)	*10)	*10)	*10)	x		x	x	x	x	x	x	x		
MP204 (Motorprotection)		x			1	x	x		*10)	*10)	*10)	*10)	*10)	*10)	x									x	x	

A= Autoadapt, Δp= Differential Pressure, P= Const. Pressure, PP= Proportional Pressure, T= Const. Temperature, Dt= Differential Temperature, F= Const Flow, S= Const. Speed/Frequency, L=Level, pH=pH-Wert, Cl2= Chlorine, ClO2=Chlorine dioxide, O3=Ozone, PAA=Peracetic acid, H2O2=Hydrogen peroxide, FA=FlowAdapt

*1) MAGNA3 cascade up to 2 pumps without ext. controller
 *2) TPED
 *3) E-pumps MGE model H/I/J cascade up to 2 pumps, with external Control MPC cascade up to 6 pumps possible. Note: data point "heat energy" only on twinpump available.

*4) All MGEs model H/I/J: 2 relays
 *5) MGE model H/I/J: CIM interfaces, TPED and MGE model F/G: CIU interfaces
 *6) version CIM xx2 needed
 *7) DDA Option E-Box Profibus

*8) for GRM alternative solution: G501
 *9) CIM interfaces
 *10) CIU interfaces
 *11) incl. differential pressure sensor
 *12) 4-20 mA Sensor required x available

DHW production		Features Pumps														Pumps										
Recommended product types: Temperature control	Control (depend on connected sensor)	single pump	parallel cascade operation	Relay outputs	Grundfos GO communication	RT00 Infrared communication	BACnet MS/TP or BACnet IP communication	LONWorks data communication	PROFIBUS DP/ PROFINET data communication	Modbus RTU data communication	EtherNet/IP data communication	Modbus TCP data communication	3G/4G cellular data communication	GIC/ GRM data communication (Grundfos Remote Management) *8)	GENIBUS data communication	Ethernet (VNC Server) data communication	No external sensor required	Sensor (0/4-20mA / 0-10V)	Sensor installed over the pump	Sensor installed in the system	Analogue setpoint influence (0-10 V)	Grafic display with user interface	Start-up wizard	Motor protection	TP	UPS
		MAGNA3	Δp,A,PP,S,F,T,P,FA	x	x	*1)	2	x			*9)	*9)	*9)	*9)	*9)	*9)	*9)		x	x	x	x	x	x	x	x
E-pump TPE	Δp,A,PP,S,F,T,P,FA	x	x	*3)	*4)	x	x		*5)	*5)	*5)	*5)	*5)	*5)	*5)		x	x	x	x	x	x	x	x		
E-pump TPE (MGE model H/I/J)	Δp,A,PP,S,F,T,P,FA	x	x	x	*3)	2	x	x	*9)	*9)	*9)	*9)	*9)	*9)	*9)		x	x	x	x	x	x	x	x		x
Control MPC (CU352)	Δp,PP,S,F,Dt,T,P	x	x	x	2				*9)	*9)	*9)	*9)	*9)	*9)	*9)	x		x	x	x	x	x	x	x		
Control MPC series 2000 (CU352)	Δp,PP,S,F,Dt,T,P	x	x		2				*9)	*9)	*9)	*9)	*9)	*9)	*9)	x		x	x	x	x	x	x	x		
CUE (Frequency converter)	Δp,PP,S,F,Dt,T,P,L	x	x	*3)	2				*10)	*10)	*10)	*10)	*10)	*10)	*10)	x		x	x	x	x	x	x	x		
MP204 (Motorprotection)		x			1	x	x		*10)	*10)	*10)	*10)	*10)	*10)	x									x	x	

A= Autoadapt, Δp= Differential Pressure, P= Const. Pressure, PP= Proportional Pressure, T= Const. Temperature, Dt= Differential Temperature, F= Const Flow, S= Const. Speed/Frequency, L=Level, pH=pH-Wert, Cl2= Chlorine, ClO2=Chlorine dioxide, O3=Ozone, PAA=Peracetic acid, H2O2=Hydrogen peroxide, FA=FlowAdapt

*1) MAGNA3 cascade up to 2 pumps without ext. controller
 *2) TPED
 *3) E-pumps MGE model H/I/J cascade up to 2 pumps, with external Control MPC cascade up to 6 pumps possible. Note: data point "heat energy" only on twinpump available.

*4) All MGEs model H/I/J: 2 relays
 *5) MGE model H/I/J: CIM interfaces, TPED and MGE model F/G and TPE mod. J: CIU interfaces
 *6) version CIM xx2 needed
 *7) DDA Option E-Box Profibus

*8) for GRM alternative solution: G501
 *9) CIM interfaces
 *10) CIU interfaces
 *11) incl. differential pressure sensor
 *12) 4-20 mA Sensor required x available

3.4 COOLING TOWER RECIRCULATION

The chiller varies its performance according to the cooling demand of the system. The cooling tower has to be controlled, in order to keep a constant return water temperature for the condenser.

Usually, the cooling tower water flow is controlled by a three-way valve. The condenser has a constant flow, normally adjusted by a regulating valve.

As an alternative, we recommend control of cooling tower water flow by variable speed pumps. Pumps adapt their speed according to the return water temperature measured by the sensor. The complete system has a variable flow, and therefore maximum energy savings can be obtained. In such systems, risk of frost will involve the use of glycol mixture.

Temperature sensor is placed on the return pipe. When using TPE2 pumps, no motor protection is necessary, but for bigger systems, a pump control unit must be added for parallel operation. For bigger systems, motor protection and pump control unit are necessary. An open cooling tower must be located on the upper point of the circuit. This in order to obtain a sufficient inlet pressure to avoid cavitation in the pump.

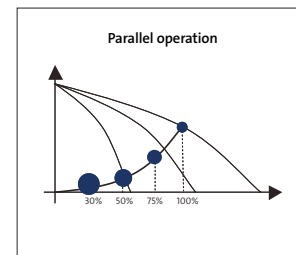
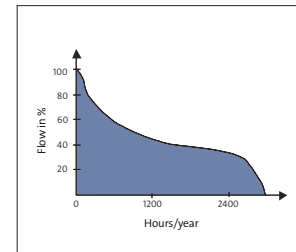
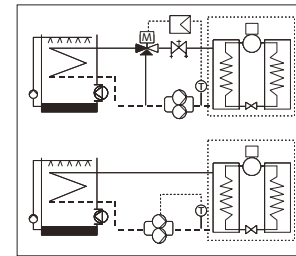

3.5 HEATING RECOVERING

If there is a demand for Domestic Hot Water when the air conditioning system is in operation it is a good idea to recover the energy from the condenser to preheat the water. It can be done in a storage tank or via a heat exchanger. The pump most only be in operation together with the chiller and when the temperature of the cold water is below the temperature in the condenser.

This can be secured by either an ON/OFF control or a temperature controlled pump. Using temperature control the maximum allowed coming back to the condenser will be the set point and can be measured in the bottom of the storage tank. The Start/Stop function for in the pump can be used.

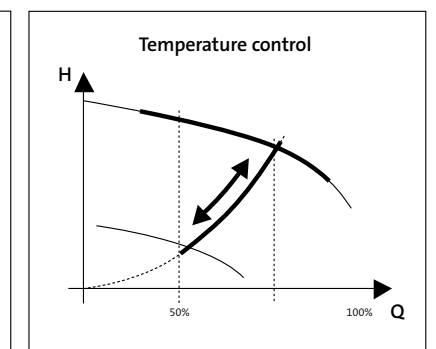
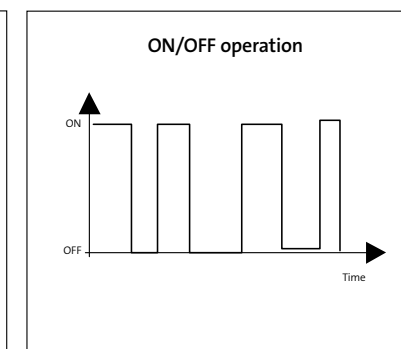
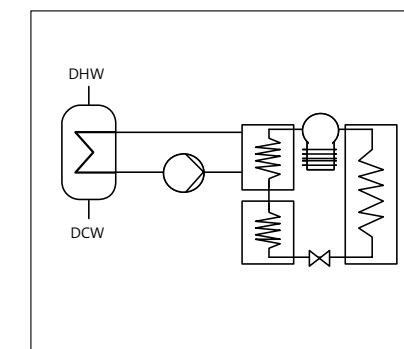

Cooling Tower recirculation		Features Pumps														Pumps												
Recommended product types: Temperature control	Control (depend on connected sensor)	single pump	standby	parallel cascade operation	Relay outputs	Non e-pump	Groundfos GO communication	RTIO Infrared communication	BACnet MS/TP or BACnet IP communication	LONWorks data communication	PROFIBUS DP/ PROFINET data communication	Modbus RTU data communication	EtherNet/IP data communication	Modbus TCP data communication	3G/4G cellular data communication	GIC/ GRM (Grundfos Remote Management) *8)	GENiBus data communication	Ethernet (VNC Server) data communication	No external sensor required	Sensor (0)4-20mA / 0-10V	Sensor installed over the pump	Sensor installed in the system	Analogue setpoint influence (0-10 V)	Graphic display with user interface	Start-up wizard	Motor protection	TP	NB, NK
		MAGNA3	Δp,A,PP,S,F,T,P,FA	x	x	*1)	2	x		*9)	*9)	*9)	*9)	*9)	*9)	*9)	*9)	*9)	x	x	x	x	x	x	x	x	x	x
E-pump TPE, NBE, NKE	Δp,A,S,F,T,P,FA	x	x	*3)	*4)	x	x	*5)	*5)	*5)	*5)	*5)	*5)	*5)	*5)	*5)			x	x	x	x	x	x	x	x		
E-pump TPE,NBE,NKE (MGE model H/I/J)	Δp,A,S,F,T,P,FA	x	x	x	2	x	x	*5)	*5)	*5)	*5)	*5)	*5)	*5)	*5)	*5)			x	x	x	x	x	x	x	x		
Control MPC (CU352)	Δp,PP,S,F,Dt,T,P	x	x	x	2			*9)	*9)	*9)	*9)	*9)	*9)	*9)	*9)	*9)	x	x	x	x	x	x	x	x	x	x		
Control MPC series 2000 (CU352)	Δp,PP,S,F,Dt,T,P	x	x		2			*9)	*9)	*9)	*9)	*9)	*9)	*9)	*9)	*9)	x	x	x	x	x	x	x	x	x			
CUE (Frequency converter)	Δp,PP,S,F,Dt,T,P,L	x	x	*3)	x	2		*10)	*10)	*10)	*10)	*10)	*10)	*10)	*10)	*10)	x		x	x	x	x	x	x	x	x		
MP204 (Motorprotection)		x			1	x	x			*10)	*10)	*10)	*10)	*10)	*10)	x									x	x	x	

A= Autoadapt, Dp= Differential Pressure, P= Const. Pressure, PP= Proportional Pressure, T= Const. Temperature, Dt= Differential Temperature, F= Const Flow, S= Const. Speed/Frequency, L=Level, pH=pH-Wert, Cl2= Chlorine, ClO2=Chlorine dioxide, O3=Ozone, PAA=Peracetic acid, H2O2=Hydrogen peroxide, FA=FlowAdapt

*1) MAGNA3 cascade up to 2 pumps without ext. controller
 *2) TPED
 *3) E-pumps MGE model H/I/J cascade up to 2 pumps, with external Control MPC cascade up to 6 pumps possible. Note: data point "heat energy" only on twinpump available.
 *4) All MGEs model H/I/J: 2 relays
 *5) MGE model H/I/J: CIM interfaces, TPED and MGE model F/G and TPE mod. J: CIU interfaces
 *6) version CIM xx2 needed
 *7) DDA Option E-Box Profibus
 *8) for GRM alternative solution: G501
 *9) CIM interfaces
 *10) CIU interfaces
 *11) incl. differential pressure sensor
 *12) 4-20 mA Sensor required
 x available

Heat recovering		Features Pumps														Pumps												
Recommended product types: Temperature control	Control (depend on connected sensor)	single pump	standby	parallel cascade operation	Relay outputs	Non e-pump	Groundfos GO communication	RTIO Infrared communication	BACnet MS/TP or BACnet IP communication	LONWorks data communication	PROFIBUS DP/ PROFINET data communication	Modbus RTU data communication	EtherNet/IP data communication	Modbus TCP data communication	3G/4G cellular data communication	GIC/ GRM (Grundfos Remote Management) *8)	GENiBus data communication	Ethernet (VNC Server) data communication	No external sensor required	Sensor (0)4-20mA / 0-10V	Sensor installed over the pump	Sensor installed in the system	Analogue setpoint influence (0-10 V)	Graphic display with user interface	Start-up wizard	Motor protection	TP	NB, NK
		MAGNA3	Δp,A,PP,S,F,T,P,FA	x	x	*1)	2	x		*9)	*9)	*9)	*9)	*9)	*9)	*9)	*9)	*9)	x	x	x	x	x	x	x	x	x	x
E-pump TPE, NBE, NKE	Δp,A,S,F,T,P,FA	x	x	*3)	*4)	x	x	*5)	*5)	*5)	*5)	*5)	*5)	*5)	*5)	*5)			x	x	x	x	x	x	x	x		
E-pump TPE,NBE,NKE (MGE model H/I/J)	Δp,A,S,F,T,P,FA	x	x	x	2	x	x	*5)	*5)	*5)	*5)	*5)	*5)	*5)	*5)	*5)			x	x	x	x	x	x	x	x		
Control MPC (CU352)	Δp,PP,S,F,Dt,T,P	x	x	x	2			*9)	*9)	*9)	*9)	*9)	*9)	*9)	*9)	*9)	x	x	x	x	x	x	x	x	x	x		
Control MPC series 2000 (CU352)	Δp,PP,S,F,Dt,T,P	x	x		2			*9)	*9)	*9)	*9)	*9)	*9)	*9)	*9)	*9)	x	x	x	x	x	x	x	x	x			
CUE (Frequency converter)	Δp,PP,S,F,Dt,T,P,L	x	x	*3)	x	2		*10)	*10)	*10)	*10)	*10)	*10)	*10)	*10)	*10)	x		x	x	x	x	x	x	x	x		
MP204 (Motorprotection)		x			1	x	x			*10)	*10)	*10)	*10)	*10)	*10)	x									x	x	x	

A= Autoadapt, Dp= Differential Pressure, P= Const. Pressure, PP= Proportional Pressure, T= Const. Temperature, Dt= Differential Temperature, F= Const Flow, S= Const. Speed/Frequency, L=Level, pH=pH-Wert, Cl2= Chlorine, ClO2=Chlorine dioxide, O3=Ozone, PAA=Peracetic acid, H2O2=Hydrogen peroxide, FA=FlowAdapt

*1) MAGNA3 cascade up to 2 pumps without ext. controller
 *2) TPED
 *3) E-pumps MGE model H/I/J cascade up to 2 pumps, with external Control MPC cascade up to 6 pumps possible. Note: data point "heat energy" only on twinpump available.
 *4) All MGEs model H/I/J: 2 relays
 *5) MGE model H/I/J: CIM interfaces, TPED and MGE model F/G and TPE mod. J: CIU interfaces
 *6) version CIM xx2 needed
 *7) DDA Option E-Box Profibus
 *8) for GRM alternative solution: G501
 *9) CIM interfaces
 *10) CIU interfaces
 *11) incl. differential pressure sensor
 *12) 4-20 mA Sensor required
 x available

3.6 PRESSURE HOLDING

In stead of using a large closed pressure tank, one or more pumps together with an open storage tank will keep a constant static pressure in the system. If the system pressure is exceeding the allowable level a relief valve will lead the water back to the tank. It is recommended to use treated water. It is recommendable always to install a standby pump. If the system is used for refilling the system please note that there is a risk of cavitation in the pump when the system pressure is very low. To avoid this the flow from the pump has to be throttled down.

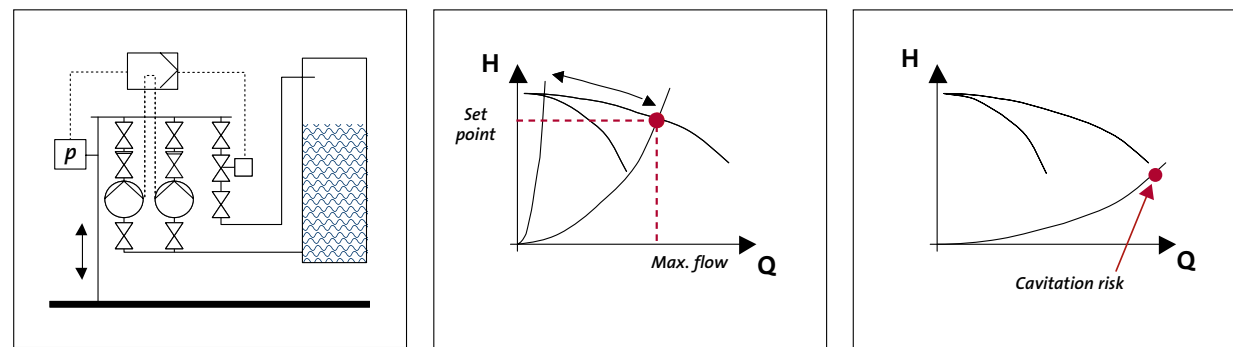

3.7 TERTIARY PUMPS

A cooler battery cools the air, which is blown into the building through the air conditioning system. The temperature in the cooler battery is dependent on the outside temperature and is controlled via the air conditioning system's control unit. To ensure a good heat transmission coefficient, the system requires a constant flow. The cooler battery output is controlled by a temperature controller, using a mixing circuit equipped with either a two-way or three-way valve. Normally the flow is adjusted by a regulating Valve but it may be an advantage to use a variable speed pump.

Cooling Ceiling/ Floors

Due to the risk of condensation, the flow temperature through a chilled beam/floor network must be higher than the temperature in the pipe-work from the chiller. A mixing circuit equipped with either two-way or three-way valves controls this temperature. Due to variation in use and cooling demand in different parts of the building, the cooling duty of the chilled beam / floor network is controlled by two-way valves via a room control unit. By varying the speed of the pump, it is possible to increase the electrical energy saving of the system. It is important to check the efficiency at the duty point where the system has a high number of operating hours. Using MAGNA3 or TPE3 there is no need for an external pressure sensor and a motor protection. It is possible to have proportional pressure without a sensor placed in the system.

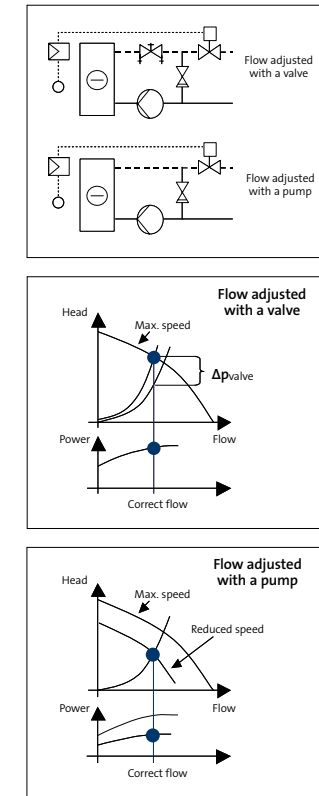

Pressure holding pumps		Features Pumps														Pumps										
Recommended product types: Pressure control	Control (depend on connected sensor)	single pump duty / standby	parallel cascade operation	Non e-pump Relay outputs	Grundfos GO communication	R100 Infrared communication	BACnet MS/TP or BACnet IP communication	LONWorks data communication	PROFIBUS DP/ PROFINET data communication	Modbus RTU data communication	EtherNet/IP data communication	Modbus TCP data communication	3C/4G cellular data communication	GIC/ GRM (Grundfos Remote Management) *8)	GENIBUS data communication	Ethernet (VNC Server) data communication	No external sensor required	Sensor (0)4-20mA / 0-10V	Sensor installed over the pump	Sensor installed in the system	Analogue setpoint influence (0-10 V)	Grafic display with user interface	Start-up wizard	Motor protection	CR	CM
		E-pump CRE	P	x	x	*3)	*4)	x	x	*5)	*5)	*5)	*5)	*5)	*5)	*5)	*5)		x	x	x	x	x	x	x	x
E-pump CRE (MGE model H/I/J)	P	x	x	x	*3)	2	x	*5)	*5)	*5)	*5)	*5)	*5)	*5)	*5)		x	x	x	x	x	x	x	x		
Control MPC (CU352)	Δp,PP,S,F,Dt,T,P	x	x	x	2	x	*9)	*9)	*9)	*9)	*9)	*9)	*9)	*9)	*9)	x	x	x	x	x	x	x	x	x		
Control MPC series 2000 (CU352)	Δp,PP,S,F,Dt,T,P	x	x	2		*9)	*9)	*9)	*9)	*9)	*9)	*9)	*9)	*9)	*9)	x	x	x	x	x	x	x	x	x		
HydroMPC (CU352)	P	x	x	2		*9)	*9)	*9)	*9)	*9)	*9)	*9)	*9)	*9)	*9)	x	x	x	x	x	x	x	x	x		
CUE (Frequency converter)	Δp,PP,S,F,Dt,T,P,L	x	x	*3)	x	2		*10)	*10)	*10)	*10)	*10)	*10)	*10)	*10)	x	x	x	x	x	x	x	x	x		
MP204 (Motorprotection)		x		x	1	x	x		*10)	*10)	*10)	*10)	*10)	*10)	x									x	x	

A= Autoadapt, Dp= Differential Pressure, P= Const. Pressure, PP= Proportional Pressure, T= Const. Temperature, DT= Differential Temperature, F= Const Flow, S= Const. Speed/Frequency, L=Level, pH=pH-Wert, Cl2= Chlorine, ClO2=Chlorine dioxide, O3=Ozone, PAA=Peracetic acid, H2O2=Hydrogen peroxide, FA=FlowAdapt

*1) MAGNA3 cascade up to 2 pumps without ext. controller
 *2) TPED
 *3) E-pumps MGE model H/I/J cascade up to 2 pumps, with external Control MPC cascade up to 6 pumps possible. Note: data point "heat energy" only on twinpump available.
 *4) All MGEs model H/I/J: 2 relays
 *5) MGE model H/I/J: CIM interfaces, TPED and MGE model F/G: CIU interfaces
 *6) version CIM xx2 needed
 *7) DDA Option E-Box Profibus
 *8) for GRM alternative solution: GS01
 *9) CIM interfaces
 *10) CIU interfaces
 *11) incl. differential pressure sensor
 *12) 4-20 mA Sensor required x available

Tertiary pumps/ Fan coils		Features Pumps														Pumps										
Recommended product types: Differential pressure control	Control (depend on connected sensor)	single pump duty / standby	parallel cascade operation	Non e-pump Relay outputs	Grundfos GO communication	R100 Infrared communication	BACnet MS/TP or BACnet IP communication	LONWorks data communication	PROFIBUS DP/ PROFINET data communication	Modbus RTU data communication	EtherNet/IP data communication	Modbus TCP data communication	3C/4G cellular data communication	GIC/ GRM (Grundfos Remote Management) *8)	GENIBUS data communication	Ethernet (VNC Server) data communication	No external sensor required	Sensor (0)4-20mA / 0-10V	Sensor installed over the pump	Sensor installed in the system	Analogue setpoint influence (0-10 V)	Grafic display with user interface	Start-up wizard	Motor protection	TP	UPS
		MAGNA3	Δp,A,PP,S,F,T,P,FA	x	x	*1)	2	x	x	*9)	*9)	*9)	*9)	*9)	*9)	*9)	*9)		x	x	x	x	x	x	x	x
TPE series 2000	Δp	x	*2)	*3)	*4)	x	x	*5)	*5)	*5)	*5)	*5)	*5)	*5)	*5)			*11)	*11)	x	x	x	x	x		
TPE3 (MGE model H/I/J)	Δp,A,PP,S,F,T,P	x	x	x	*3)	2	x	x	*5)	*5)	*5)	*5)	*5)	*5)	*5)			*11)	*11)	x	x	x	x	x		
E-pump TPE, NBE, NKE	Δp,A,S,F,T,P,FA	x	x	x	*3)	*4)	x	x	*5)	*5)	*5)	*5)	*5)	*5)	*5)					x	x	x	x	x		
E-pump TPE,NBE,NKE (MGE model H/I/J)	Δp,A,S,F,T,P,FA	x	x	x	*3)	2	x	x	*5)	*5)	*5)	*5)	*5)	*5)	*5)					x	x	x	x	x		
Control MPC (CU352)	Δp,PP,S,F,Dt,T,P	x	x	x	2		*9)	*9)	*9)	*9)	*9)	*9)	*9)	*9)	*9)	x	x			x	x	x	x	x		
Control MPC series 2000 (CU352)	Δp,PP,S,F,Dt,T,P	x	x	2		*9)	*9)	*9)	*9)	*9)	*9)	*9)	*9)	*9)	*9)	x	x			x	x	x	x	x		
CUE (Frequency converter)	Δp,PP,S,F,Dt,T,P,L	x	x	*3)	x	2		*10)	*10)	*10)	*10)	*10)	*10)	*10)	*10)	x				x	x	x	x	x		
MP204 (Motorprotection)		x		x	1	x	x		*10)	*10)	*10)	*10)	*10)	*10)	x									x	x	

A= Autoadapt, Dp= Differential Pressure, P= Const. Pressure, PP= Proportional Pressure, T= Const. Temperature, DT= Differential Temperature, F= Const Flow, S= Const. Speed/Frequency, L=Level, pH=pH-Wert, Cl2= Chlorine, ClO2=Chlorine dioxide, O3=Ozone, PAA=Peracetic acid, H2O2=Hydrogen peroxide, FA=FlowAdapt

*1) MAGNA3 cascade up to 2 pumps without ext. controller
 *2) TPED
 *3) E-pumps MGE model H/I/J cascade up to 2 pumps, with external Control MPC cascade up to 6 pumps possible. Note: data point "heat energy" only on twinpump available.
 *4) All MGEs model H/I/J: 2 relays
 *5) MGE model H/I/J: CIM interfaces, TPED and MGE model F/G and TPE mod. J: CIU interfaces
 *6) version CIM xx2 needed
 *7) DDA Option E-Box Profibus
 *8) for GRM alternative solution: GS01
 *9) CIM interfaces
 *10) CIU interfaces
 *11) incl. differential pressure sensor
 *12) 4-20 mA Sensor required x available

3.7.B TERTIARY PUMPS

Fan Coils

In order to avoid too cold air flow, the flow temperature through the fan coil network must be higher the water temperature from the chiller.

A mixing circuit with either two-way or three-way valves controls this temperature.

Due to variation in use and cooling demand in different parts of the building, the cooling duty of the fan coil network is controlled by two-way valves via a room control unit. By varying the speed of the pump, it is possible to increase the electrical energy saving of the system.

It is important to check the efficiency at the duty point where the system has a high number of operating hours.

Using TPE3 or MAGNA3 there is no need for an external pressure sensor and a motor protection. It is possible to have proportional pressure without a sensor placed in the system.

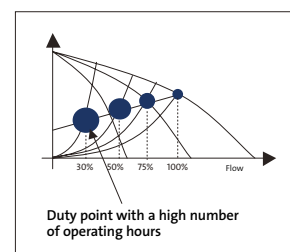
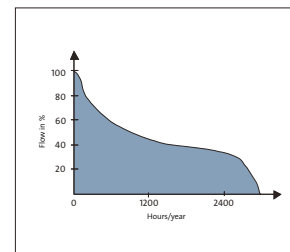
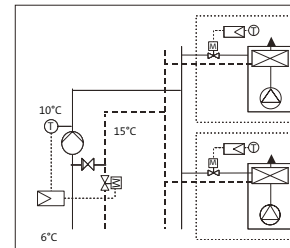

3.8 MIXING LOOPS

Due to variation in use and heat demand in different parts of the building, the system is divided into zones controlled by a mixing loop. The flow temperature will be lower than in the mains supply, which will result in a higher flow in the zone than in the mains supply. This will help obtain a better hydraulic balance in the total system. Speed controlling the pump makes it possible to obtain the maximum energy saving.

When using a two-way valve, the pressure lost in the valve will be managed by the main pump. When using a three-way valve, the pump in the mixing loop also has to manage the pressure lost in the valve.

Using MAGNA3 or TPE3 pumps there is no need for an external pressure sensor and a motor protection. It is possible to have proportional pressure without a sensor placed in the system.

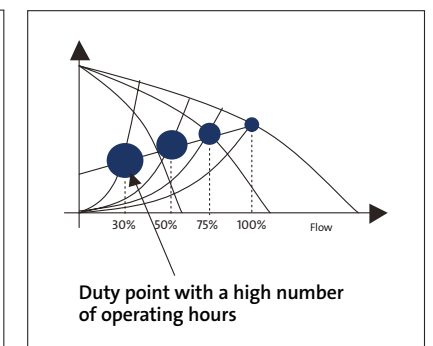
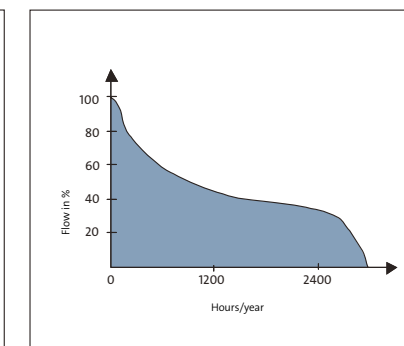
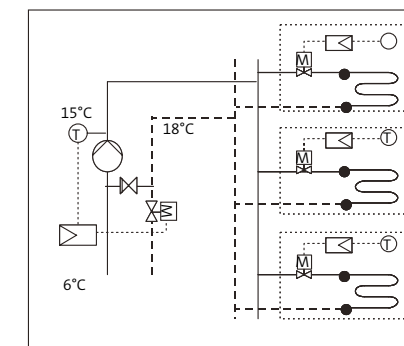

Tertiary pumps/ Fan coils		Features Pumps														Pumps													
Recommended product types: Differential pressure control	Control (depend on connected sensor)	single pump	duty / standby	parallel cascade operation	Non e-pump	Relay outputs	Grundfos GO communication	RTIO Infrared communication	BACnet MS/TP or BACnet IP communication	LONWorks data communication	PROFIBUS DP/ PROFINET data communication	Modbus RTU data communication	EtherNet/IP data communication	Modbus TCP data communication	3G/4G cellular data communication	GIC/ GRM (Grundfos Remote Management) *8)	GENIBUS data communication	Ethernet (VNC Server) data communication	No external sensor required	Sensor (0)4-20mA / 0-10V	Sensor installed over the pump	Sensor installed in the system	Analogue setpoint influence (0-10 V)	Graphic display with user interface	Start-up wizard	Motor protection	TP	UPS	
		MAGNA3	Δp,A,PP,S,F,T,P,FA	x	x	*1)	2	x	*9)	*9)	*9)	*9)	*9)	*9)	*9)	*9)	*9)	*9)	x	x	x	x	x	x	x	x	x	x	x
TPE series 2000	Δp	x	*2)	*3)	*4)	x	*5)	*5)	*5)	*5)	*5)	*5)	*5)	*5)	*5)	*5)			*11)	*11)	x	x	x	x	x	x	x		
TPE3 (MGE model H/I/J)	Δp	x	x	x	2	x	*5)	*5)	*5)	*5)	*5)	*5)	*5)	*5)	*5)	*5)			*11)	*11)	x	x	x	x	x	x	x		
E-pump TPE, NBE, NKE	Δp,A,S,F,T,P,FA	x	x	*3)	*4)	x	*5)	*5)	*5)	*5)	*5)	*5)	*5)	*5)	*5)	*5)			x	x	x	x	x	x	x	x	x		
E-pump TPE,NBE,NKE (MGE model H/I/J)	Δp,A,S,F,T,P,FA	x	x	*3)	2	x	*5)	*5)	*5)	*5)	*5)	*5)	*5)	*5)	*5)	*5)			x	x	x	x	x	x	x	x	x		
Control MPC (CU352)	Δp,PP,S,F,Dt,T,P	x	x	x	2		*9)	*9)	*9)	*9)	*9)	*9)	*9)	*9)	*9)	*9)	x	x	x	x	x	x	x	x	x	x	x		
Control MPC series 2000 (CU352)	Δp,PP,S,F,Dt,T,P	x	x	x	2		*9)	*9)	*9)	*9)	*9)	*9)	*9)	*9)	*9)	*9)	x	x	x	x	x	x	x	x	x	x	x		
CUE (Frequency converter)	Δp,PP,S,F,Dt,T,P,L	x	x	*3)	x	2		*10)	*10)	*10)	*10)	*10)	*10)	*10)	*10)	*10)	x	x	x	x	x	x	x	x	x	x	x		
MP204 (Motorprotection)		x			x	1	x			*10)	*10)	*10)	*10)	*10)	*10)	x										x	x		

A= Autoadapt, Dp= Differential Pressure, P= Const. Pressure, PP= Proportional Pressure, T= Const. Temperature, Dt= Differential Temperature, F= Const Flow, S= Const. Speed/Frequency, L=Level, pH=pH-Wert, Cl2= Chlorine, ClO2=Chlorine dioxide, O3=Ozone, PAA=Peracetic acid, H2O2=Hydrogen peroxide, FA=FlowAdapt

*1) MAGNA3 cascade up to 2 pumps without ext. controller
 *2) TPED
 *3) E-pumps MGE model H/I/J cascade up to 2 pumps, with external Control MPC cascade up to 6 pumps possible. Note: data point "heat energy" only on twinpump available.
 *4) All MGEs model H/I/J: 2 relays
 *5) MGE model H/I/J: CIM interfaces, TPED and MGE model F/G and TPE mod. J: CIU interfaces
 *6) version CIM xx2 needed
 *7) DDA Option E-Box Profibus
 *8) for GRM alternative solution: G501
 *9) CIM interfaces
 *10) CIU interfaces
 *11) incl. differential pressure sensor
 *12) 4-20 mA Sensor required x available

Mixing loops		Features Pumps														Pumps													
Recommended product types: Differential pressure control	Control (depend on connected sensor)	single pump	duty / standby	parallel cascade operation	Non e-pump	Relay outputs	Grundfos GO communication	RTIO Infrared communication	BACnet MS/TP or BACnet IP communication	LONWorks data communication	PROFIBUS DP/ PROFINET data communication	Modbus RTU data communication	EtherNet/IP data communication	Modbus TCP data communication	3G/4G cellular data communication	GIC/ GRM (Grundfos Remote Management) *8)	GENIBUS data communication	Ethernet (VNC Server) data communication	No external sensor required	Sensor (0)4-20mA / 0-10V	Sensor installed over the pump	Sensor installed in the system	Analogue setpoint influence (0-10 V)	Graphic display with user interface	Start-up wizard	Motor protection	TP	UPS	
		MAGNA3	Δp,A,PP,S,F,T,P,FA	x	x	*1)	2	x	*9)	*9)	*9)	*9)	*9)	*9)	*9)	*9)	*9)	*9)	x	x	x	x	x	x	x	x	x	x	x
TPE series 2000	Δp	x	*2)	*3)	*4)	x	*5)	*5)	*5)	*5)	*5)	*5)	*5)	*5)	*5)	*5)			*11)	*11)	x	x	x	x	x	x	x		
TPE3 (MGE model H/I/J)	Δp	x	x	x	2	x	*5)	*5)	*5)	*5)	*5)	*5)	*5)	*5)	*5)	*5)			*11)	*11)	x	x	x	x	x	x	x		
E-pump TPE, NBE, NKE	Δp,A,S,F,T,P,FA	x	x	*3)	*4)	x	*5)	*5)	*5)	*5)	*5)	*5)	*5)	*5)	*5)	*5)			x	x	x	x	x	x	x	x	x		
E-pump TPE,NBE,NKE (MGE model H/I/J)	Δp,A,S,F,T,P,FA	x	x	*3)	2	x	*5)	*5)	*5)	*5)	*5)	*5)	*5)	*5)	*5)	*5)			x	x	x	x	x	x	x	x	x		
Control MPC (CU352)	Δp,PP,S,F,Dt,T,P	x	x	x	2		*9)	*9)	*9)	*9)	*9)	*9)	*9)	*9)	*9)	*9)	x	x	x	x	x	x	x	x	x	x	x		
Control MPC series 2000 (CU352)	Δp,PP,S,F,Dt,T,P	x	x	x	2		*9)	*9)	*9)	*9)	*9)	*9)	*9)	*9)	*9)	*9)	x	x	x	x	x	x	x	x	x	x	x		
CUE (Frequency converter)	Δp,PP,S,F,Dt,T,P,L	x	x	*3)	x	2		*10)	*10)	*10)	*10)	*10)	*10)	*10)	*10)	*10)	x	x	x	x	x	x	x	x	x	x	x		
MP204 (Motorprotection)		x			x	1	x			*10)	*10)	*10)	*10)	*10)	*10)	x										x	x		

A= Autoadapt, Dp= Differential Pressure, P= Const. Pressure, PP= Proportional Pressure, T= Const. Temperature, Dt= Differential Temperature, F= Const Flow, S= Const. Speed/Frequency, L=Level, pH=pH-Wert, Cl2= Chlorine, ClO2=Chlorine dioxide, O3=Ozone, PAA=Peracetic acid, H2O2=Hydrogen peroxide, FA=FlowAdapt

*1) MAGNA3 cascade up to 2 pumps without ext. controller
 *2) TPED
 *3) E-pumps MGE model H/I/J cascade up to 2 pumps, with external Control MPC cascade up to 6 pumps possible. Note: data point "heat energy" only on twinpump available.
 *4) All MGEs model H/I/J: 2 relays
 *5) MGE model H/I/J: CIM interfaces, TPED and MGE model F/G and TPE mod. J: CIU interfaces
 *6) version CIM xx2 needed
 *7) DDA Option E-Box Profibus
 *8) for GRM alternative solution: G501
 *9) CIM interfaces
 *10) CIU interfaces
 *11) incl. differential pressure sensor
 *12) 4-20 mA Sensor required x available

4.4 PRESSURE HOLDING

In stead of using a large closed pressure tank, one or more pumps together with an open storage tank will keep a constant static pressure in the system. If the system pressure is exceeding the allowable level a relief valve will lead the water back to the tank. It is recommended to use treated water. It is recommendable always to install a standby pump. If the system is used for refilling the system please note that there is a risk of cavitation in the pump when the system pressure is very low. To avoid this the flow from the pump has to be throttled down.

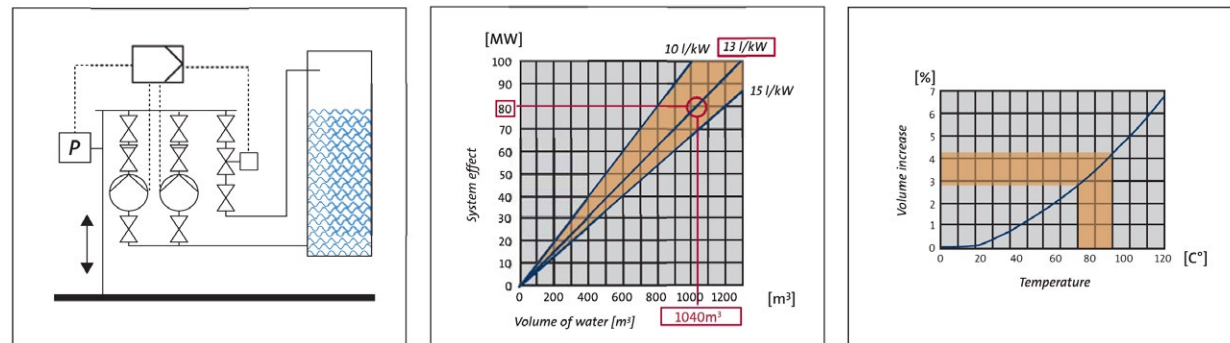

Recommended product types: Differential pressure control	Control (depend on connected sensor)	Features Pumps																Pumps											
		single pump	duty / standby	parallel cascade operation	Non e-pump	Relay outputs	Grundfos GO communication	R100 Infrared communication	BACnet MS/TP or BACnet IP communication	LONWorks data communication	PROFIBUS DP/ PROFINET data communication	Modbus RTU data communication	EtherNet/IP data communication	Modbus TCP data communication	3G/4G cellular data communication	GiC/ GRM (Grundfos Remote Management) * 8)	GENibus data communication	Ethernet (VNC Server) data communication	No external sensor required	Sensor (0)4-20mA / 0-10V	Sensor installed over the pump	Sensor installed in the system	Analogue setpoint influence (0-10 V)	Graphic display with user interface	Start-up wizard	Motor protection	CR	CM	
E-pump CRE	P	x	x	*3)	*4)	x	x	*5)	*5)	*5)	*5)	*5)	*5)	*5)	*5)	*5)			x	x	x	x	x	x	x	x	x		
E-pump CRE (MGE model H/I/J)	P	x	x	x	*3)	2	x	*5)	*5)	*5)	*5)	*5)	*5)	*5)	*5)	*5)			x	x	x	x	x	x	x	x	x		
Control MPC (CU352)	Δp,PP,S,F,Dt,T,P	x	x	x	2	x	*9)	*9)	*9)	*9)	*9)	*9)	*9)	*9)	*9)	x		x	x	x	x	x	x	x	x	x	x		
Control MPC series 2000 (CU352)	Δp,PP,S,F,Dt,T,P	x	x	2		*9)	*9)	*9)	*9)	*9)	*9)	*9)	*9)	*9)	x		x	x	x	x	x	x	x	x	x	x	x		
HydroMPC (CU352)	P	x	x	2		*9)	*9)	*9)	*9)	*9)	*9)	*9)	*9)	*9)	x		x	x	x	x	x	x	x	x	x	x	x		
CUE (Frequency converter)	Δp,PP,S,F,Dt,T,P,L	x	x	*3)	x	2		*10)	*10)	*10)	*10)	*10)	*10)	*10)	x		x	x	x	x	x	x	x	x	x	x	x		
MP204 (Motorprotection)		x		x	1	x	x		*10)	*10)	*10)	*10)	*10)	x													x	x	x

A= Autoadapt, Dp= Differential Pressure, P= Const. Pressure, PP= Proportional Pressure, T= Const. Temperature, Dt= Differential Temperature, F= Const Flow, S= Const. Speed/Frequency, L=Level, pH=pH-Wert, Cl2= Chlorine, ClO2=Chlorine dioxide, O3=Ozone, PAA=Peracetic acid, H2O2=Hydrogen peroxide, FA=FlowAdapt

- *1) MAGNA3 cascade up to 2 pumps without ext. controller
- *2) TPED
- *3) E-pumps MGE model H/I/J cascade up to 2 pumps, with external Control MPC cascade up to 6 pumps possible. Note: data point "heat energy" only on twinpump available.
- *4) All MGEs model H/I/J: 2 relays
- *5) MGE model H/I/J: CIM interfaces, TPED and MGE model F/G: CIU interfaces
- *6) version CIM xx2 needed
- *7) DDA Option E-Box Profibus
- *8) for GRM alternative solution: G501
- *9) CIM interfaces
- *10) CIU interfaces
- *11) incl. differential pressure sensor
- *12) 4-20 mA Sensor required x available

4.5 BOOSTER PUMPS

Booster pumps
In Instead of using a large closed pressure tank, one or more pumps together with an open storage tank will maintain constant static pressure in the system. If the system pressure exceeds the allowable level, a relief valve will lead the water back to the tank. It is recommended that treated water be used.

The set point will be the static pressure of the system.

It is recommendable always to install a standby pump. If the system is used for refilling the system please note that there is a risk of cavitation in the pump when the system pressure is very low. To avoid this the flow from the pump has to be throttled down.

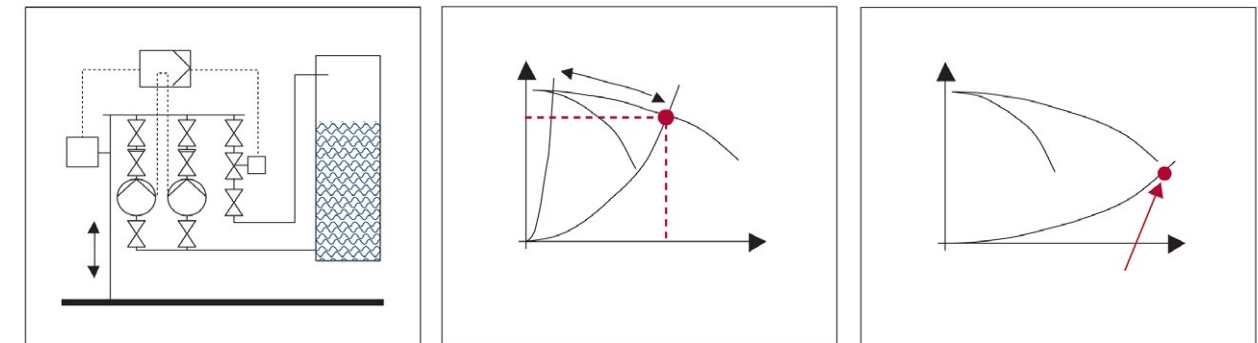

Recommended product types: Pressure control	Control (depend on connected sensor)	Features Pumps																Pumps											
		single pump	duty / standby	parallel cascade operation	Non e-pump	Relay outputs	Grundfos GO communication	R100 Infrared communication	BACnet MS/TP or BACnet IP communication	LONWorks data communication	PROFIBUS DP/ PROFINET data communication	Modbus RTU data communication	EtherNet/IP data communication	Modbus TCP data communication	3G/4G cellular data communication	GiC/ GRM (Grundfos Remote Management) * 8)	GENibus data communication	Ethernet (VNC Server) data communication	No external sensor required	Sensor (0)4-20mA / 0-10V	Sensor installed over the pump	Sensor installed in the system	Analogue setpoint influence (0-10 V)	Graphic display with user interface	Start-up wizard	Motor protection	CR	CM	
E-pump CRE	P	x	x	*3)	*4)	x	x	*5)	*5)	*5)	*5)	*5)	*5)	*5)	*5)			x	x	x	x	x	x	x	x	x			
E-pump CRE (MGE model H/I/J)	P	x	x	x	*3)	2	x	*5)	*5)	*5)	*5)	*5)	*5)	*5)	*5)			x	x	x	x	x	x	x	x	x	x		
Control MPC (CU352)	Δp,PP,S,F,Dt,T,P	x	x	x	2	x	*9)	*9)	*9)	*9)	*9)	*9)	*9)	*9)	x		x	x	x	x	x	x	x	x	x	x	x		
Control MPC series 2000 (CU352)	Δp,PP,S,F,Dt,T,P	x	x	2		*9)	*9)	*9)	*9)	*9)	*9)	*9)	*9)	*9)	x		x	x	x	x	x	x	x	x	x	x	x		
HydroMPC (CU352)	P	x	x	2		*9)	*9)	*9)	*9)	*9)	*9)	*9)	*9)	*9)	x		x	x	x	x	x	x	x	x	x	x	x		
CUE (Frequency converter)	Δp,PP,S,F,Dt,T,P,L	x	x	*3)	x	2		*10)	*10)	*10)	*10)	*10)	*10)	*10)	x		x	x	x	x	x	x	x	x	x	x	x		
MP204 (Motorprotection)		x		x	1	x	x		*10)	*10)	*10)	*10)	*10)	x													x	x	x

A= Autoadapt, Dp= Differential Pressure, P= Const. Pressure, PP= Proportional Pressure, T= Const. Temperature, Dt= Differential Temperature, F= Const Flow, S= Const. Speed/Frequency, L=Level, pH=pH-Wert, Cl2= Chlorine, ClO2=Chlorine dioxide, O3=Ozone, PAA=Peracetic acid, H2O2=Hydrogen peroxide, FA=FlowAdapt

- *1) MAGNA3 cascade up to 2 pumps without ext. controller
- *2) TPED
- *3) E-pumps MGE model H/I/J cascade up to 2 pumps, with external Control MPC cascade up to 6 pumps possible. Note: data point "heat energy" only on twinpump available.
- *4) All MGEs model H/I/J: 2 relays
- *5) MGE model H/I/J: CIM interfaces, TPED and MGE model F/G: CIU interfaces
- *6) version CIM xx2 needed
- *7) DDA Option E-Box Profibus
- *8) for GRM alternative solution: G501
- *9) CIM interfaces
- *10) CIU interfaces
- *11) incl. differential pressure sensor
- *12) 4-20 mA Sensor required x available

4.6 TERTIARY PUMPS

Cooling surface

A cooler battery cools the air, which is blown into the building through the air conditioning system. The temperature in the cooler battery is dependent on the outside temperature and is controlled via the air conditioning system's control unit. To ensure a good heat transmission coefficient, the system requires a constant flow.

The cooler battery output is controlled by a temperature controller, using a mixing circuit equipped with either a two-way or three-way valve. Normally the flow is adjusted by a regulating Valve but it may be an advantage to use a variable speed pump.

Cooling Ceiling/ Floors

Due to the risk of condensation, the flow temperature through a chilled beam/floor network must be higher than the temperature in the pipework from the chiller. A mixing circuit equipped with either two-way or three-way valves controls this temperature.

Due to variation in use and cooling demand in different parts of the building, the cooling duty of the chilled beam / floor network is controlled by two-way valves via a room control unit. By varying the speed of the pump, it is possible to increase the electrical energy saving of the system. It is important to check the efficiency at the duty point where the system has a high number of operating hours.

Using TPE3 or MAGNA3 there is no need for an external pressure sensor and a motor protection. It is possible to have proportional pressure without a sensor placed in the system.

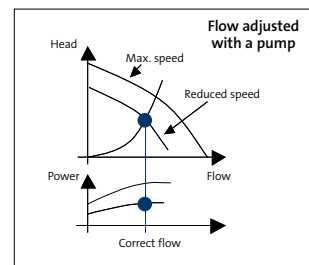
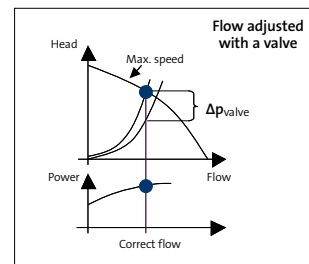
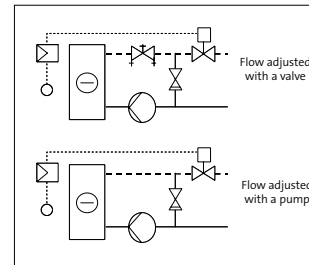

Recommended product types: Differential pressure control	Control (depend on connected sensor)	Features Pumps																	Pumps									
		single pump duty / standby	parallel cascade operation	Non e-pump	Relay outputs	Grundfos GO communication	R100 Infrared communication	BACnet MS/TP or BACnet IP communication	LONworks data communication	PROFIBUS DP/ PROFINET data communication	Modbus RTU data communication	EtherNet/IP data communication	Modbus TCP data communication	3C/4G cellular data communication	GIC/ GRM (Grundfos Remote Management) *8)	GENIbus data communication	Ethernet (VNC Server) data communication	No external sensor required	Sensor (0)4-20mA / 0-10V	Sensor installed over the pump	Sensor installed in the system	Analogue setpoint influence (0-10 V)	Graphic display with user interface	Start-up wizard	Motor protection	TP	NB, NK	
MAGNA3	Δp,A,PP,S,F,T,P,FA	x	x	*1)		2	x	*9)	*9)	*9)	*9)	*9)	*9)	*9)	*9)	*9)	x	x	x	x	x	x	x	x	x	x		
TPE series 2000	Δp	x	*2)	*3)		*4)	x	*5)	*5)	*5)	*5)	*5)	*5)	*5)	*5)			*11)	*11)									
TPE3 (MGE model H/I/J)	Δp	x	x	x		2	x	*5)	*5)	*5)	*5)	*5)	*5)	*5)	*5)			*11)	*11)			x	x	x	x	x		
E-pump TPE, NBE, NKE	Δp,A,S,F,T,P,FA	x	x	*3)		*4)	x	*5)	*5)	*5)	*5)	*5)	*5)	*5)	*5)			x	x	x	x							
E-pump TPE,NBE,NKE (MGE model H/I/J)	Δp,A,S,F,T,P,FA	x	x	*3)		2	x	*5)	*5)	*5)	*5)	*5)	*5)	*5)	*5)			x	x	x	x	x	x	x	x	x		
CUE (Frequency converter)	Δp,PP,S,F,DT,T,P,L	x	x	*3)	x	2		*10)	*10)	*10)	*10)	*10)	*10)	*10)	*10)	x		x	x	x	x	x	x	x	x	x	x	x
MP204 (Motorprotection)		x			x	1	x	x		*10)	*10)	*10)	*10)	*10)	*10)	x										x	x	x

A= Autoadapt, Dp= Differential Pressure, P= Const. Pressure, PP= Proportional Pressure, T= Const. Temperature, DT= Differential Temperature, F= Const Flow, S= Const. Speed/Frequency, L=Level, pH=pH-Wert, Cl2= Chlorine, ClO2=Chlorine dioxide, O3=Ozone, PAA=Peracetic acid, H2O2=Hydrogen peroxide, FA=FlowAdapt

*1) MAGNA3 cascade up to 2 pumps without ext. controller
 *2) TPED
 *3) E-pumps MGE model H/I/J cascade up to 2 pumps, with external Control MPC cascade up to 6 pumps possible. Note: data point "heat energy" only on twinpump available.
 *4) All MGEs model H/I/J: 2 relays
 *5) MGE model H/I/J: CIM interfaces, TPED and MGE model F/G and TPE mod. J: CIU interfaces
 *6) version CIM xx2 needed
 *7) DDA Option E-Box Profibus
 *8) for GRM alternative solution: GS01
 *9) CIM interfaces
 *10) CIU interfaces
 *11) incl. differential pressure sensor
 *12) 4-20 mA Sensor required x available

Real life calculation case

In connection with the renovation of one particular 23-year-old air-conditioning system, all the three-way control valves were replaced with two-way valves, to alter the system from constant flow to variable flow. The constant-speed pumps were also subsequently replaced with Grundfos variable-speed pumps. The following example shows the impact on the main pumps.

Area with air conditioning: 23,000 m²
 Cooling season: 7,000 hours
 Fan coils: 450 pcs.
 Air handling units: 35 pcs.
 Total cooling power: 1,200 kW

System 1

Flow: constant • Configuration: one constant-speed pump selected at best efficiency point.
 Pump configuration:

System 2

Flow: variable • Configuration: two speedcontrolled pumps
 • Control: PFU
 Pump configuration: proportional pressure control measured within the system.

Life Cycle Cost – 20 years operation

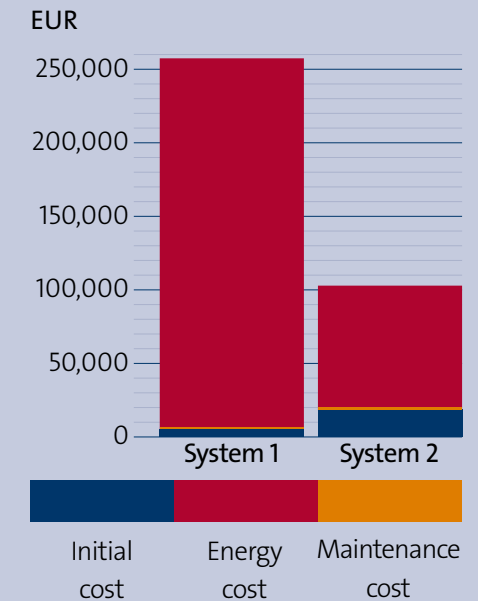

5. PRESSURE BOOSTING

MEDIUM/ LARGE BUILDINGS

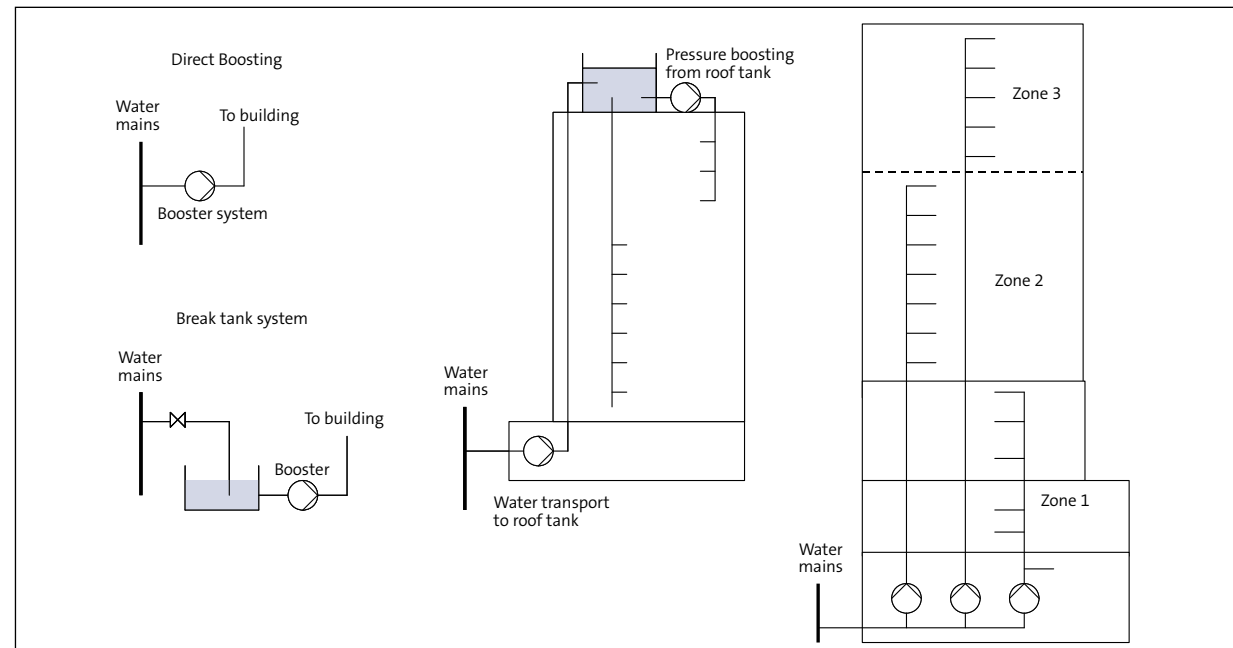

Pressure boosting large buildings is necessary whenever the public water supply is inadequate, either because of too low pressure or because of too low flow to supply the building during peak consumption. The objective is to ensure a constant pressure throughout the building. The profile depends of what the building is used for, but most multi-storey buildings are used for commercial matters. Commercial buildings have quite predictable variations during the day. The Multi-E is normally the perfect choice for this application. It has the capability to follow the fluctuations of demand because of the 2-3 speed controlled pumps, but also the reliability and user-friendliness that is needed for multi-storey buildings.

Application

Whenever water has to be moved from ground-level and upwards in a building, there is always a risk of a pipe bursting due to the pressure. The soft pressure build-up function in the MPC protects the piping during start-up of the system, and provides the user with protection from costly flooding.



5.1 PB WITH BREAK TANKS

The water supply to a building have to be reliable and comfortable. To fulfil this requirement a pressure boosting system is very recommendable. A complete pressure boosting system will automatically compensate for the variations in the pre pressure from the water mains and the variations in consumption and by varying performance – ensure that the supply pressure to the building is constant.

We recommend the speed controlled Hydro MPC E pressure boosting systems, which can give a constant pressure to the building and at the same time ensures optimum operation costs and supply security.

If system cost is very important, the lower cost systems Hydro Multi-E can be selected.

If standby pump capacity is not required, the Hydro Solo-E solution can be recommended.

Use the Consumption Profile as the basis for selecting the optimum system. The number of pumps and the size of these shall fit to profile.

Grundfos pressure boosting systems are easy to install. Connect the unit to mains supply and the piping, prime the system and we are ready to go.

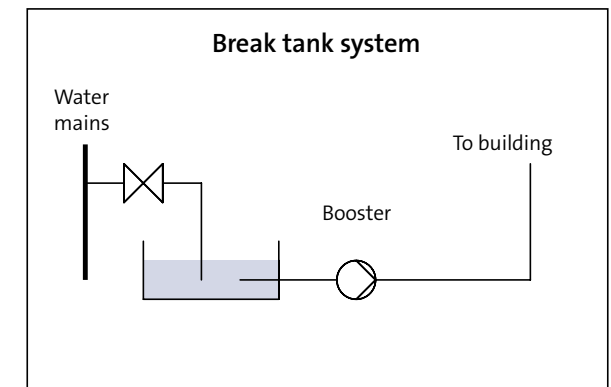

It is recommendable to install a water shortage detection on the suction side the booster. By direct boosting systems a pressure switch can be used – in case of a break tank system, a level switch in the tank will be the best solution.

Break tanks are often required in areas where:

- the piping in the mains are weak and can't stand pressure surges caused by pumps starting and stopping.
- local requirements

PB with break tank		Features Pumps														Pumps												
Recommended product types: Pressure control	Control (depend on connected sensor)	single pump	parallel cascade operation	Non e-pump	Relay outputs	Grundfos GO communication	R100 Infrared communication	BACnet MS/TP or BACnet IP communication	LONWorks data communication	PROFIBUS DP/ PROFINET data communication	Modbus RTU data communication	EtherNet/IP data communication	Modbus TCP data communication	3G/4G cellular data communication	GiC/ GRM (Grundfos Remote Management) *8)	GENIBUS data communication	Ethernet (VNC Server) data communication	No external sensor required	Sensor (0/4-20mA / 0-10V)	Sensor installed over the pump	Sensor installed in the system	Analogue setpoint influence (0-10 V)	Grafic display with user interface	Start-up wizard	Motor protection	CR	CM	
		E-pump CRE	P	x	x	*3)	*4)	x	x	*5)	*5)	*5)	*5)	*5)	*5)	*5)	*5)	x	x	x	x	x	x	x	x	x	x	x
E-pump CRE (MGE model H/I/J)	P	x	x	x	*3)	2	x	x	*5)	*5)	*5)	*5)	*5)	*5)	*5)	x	x	x	x	x	x	x	x	x	x	x		
Hydro Multi-S	P	x			1																							
Hydro Multi-E	P	x	x		1	x		*10)	*10)	*10)	*10)		*10)	*10)	*10)	x		x	x	x	x	x	x	x	x			
Control MPC (CU352)	Δp,PP,S,F,Dt,T,P	x	x	x	2			*9)	*9)	*9)	*9)	*9)	*9)	*9)	*9)	x		x	x	x	x	x	x	x	x	x	x	x
Control MPC series 2000 (CU352)	Δp,PP,S,F,Dt,T,P	x	x		2			*9)	*9)	*9)	*9)	*9)	*9)	*9)	*9)	x		x	x	x	x	x	x	x	x	x	x	x
HydroMPC (CU352)	P	x	x		2			*9)	*9)	*9)	*9)	*9)	*9)	*9)	*9)	x		x	x	x	x	x	x	x	x	x	x	x
CUE (Frequency converter)	Δp,PP,S,F,Dt,T,P,L	x	x	*3)	x	2		*10)	*10)	*10)	*10)	*10)	*10)	*10)	*10)	x		x	x	x	x	x	x	x	x	x	x	x
MP204 (Motorprotection)		x			1	x	x		*10)	*10)			*10)	*10)	x										x	x	x	x

A= Autoadapt, Dp= Differential Pressure, P= Const. Pressure, PP= Proportional Pressure, T= Const. Temperature, Dt= Differential Temperature, F= Const Flow, S= Const. Speed/Frequency, L=Level, pH=pH-Wert, Cl2= Chlorine, ClO2=Chlorine dioxide, O3=Ozone, PAA=Peracetic acid, H2O2=Hydrogen peroxide, FA=FlowAdapt

*1) MAGNA3 cascade up to 2 pumps without ext. controller
 *2) TPED
 *3) E-pumps MGE model H/I/J cascade up to 2 pumps, with external Control MPC cascade up to 6 pumps possible. Note: data point "heat energy" only on twin pump available.

*4) All MGEs model H/I/J: 2 relays
 *5) MGE model H/I/J: CIM interfaces, TPED and MGE model F/G: CIU interfaces
 *6) version CIM xx2 needed
 *7) DDA Option E-Box Profibus

*8) for GRM alternative solution: GS01
 *9) CIM interfaces
 *10) CIU interfaces
 *11) incl. differential pressure sensor
 *12) 4-20 mA Sensor required x available

5.2 PB WITH DIRECT CONNECTION

The system layout have to be considered before the booster system can be selected.

Direct boosting – or break tank

The connection to the water supply mains can either be directly or via a break tank. If direct connection is allowed this will be recommendable.

The pressure requirement to a pressure boosting system with direct connection will be less than systems with break tank, as the system then can use the water supply mains pressure as a pre-pressure.

Depending of area the water supply mains pressure typically will be in the range 1.5 – 4.0 bar.

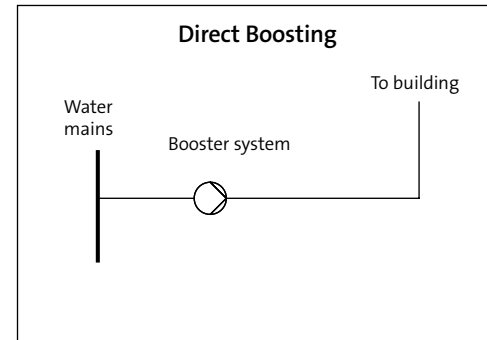

5.3. PB WITH ROOF TANKS

The system layout have to be considered before the booster system can be selected.

Roof tank systems

In some areas roof tank systems are required. The reason is to ensure water supply for a certain period also if the electrical power supply disappears.

The transfer pump can pump from a break tank or direct from supply mains.

Water supply (pressure) to the building is obtained by a Booster System, boosting down to the 3-4 upper floors. The rest of the building is supplied by gravit

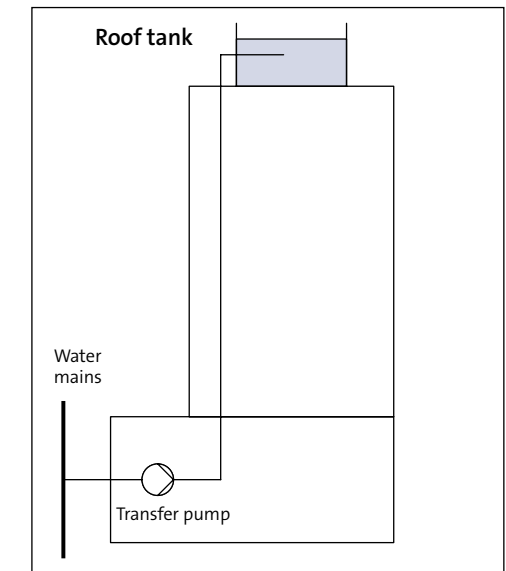

PB with direct connection		Features Pumps														Pumps												
Recommended product types: Pressure control	Control (depend on connected sensor)	single pump	duty / standby	parallel cascade operation	Non e-pump	Relay outputs	Grundfos GO communication	R100 Infrared communication	BACnet MS/TP or BACnet IP communication	LONWorks data communication	PROFIBUS DP/ PROFINET data communication	Modbus RTU data communication	EtherNet/IP data communication	Modbus TCP data communication	3C/4G cellular data communication	Gic/ GRM (Grundfos Remote Management) *8)	GENiBus data communication	Ethernet (VNC Server) data communication	No external sensor required	Sensor (0)4-20mA / 0-10V	Sensor installed over the pump	Sensor installed in the system	Analogue setpoint influence (0-10 V)	Grafic display with user interface	Start-up wizard	Motor protection	CR	CM
		E-pump CRE	P	x	x	*3)		*4)	x	x	*5)	*5)	*5)	*5)	*5)	*5)	*5)				x	x	x	x			x	
E-pump CRE (MGE model H/I/J)	P	x	x	x	*3)		2	x	x	*5)	*5)	*5)	*5)	*5)	*5)				x	x	x	x	x	x	x			
Hydro Multi-S	P	x				1																						
Hydro Multi-E	P	x	x			1	x		*10)	*10)	*10)	*10)		*10)	*10)				x	x	x	x			x			
Control MPC (CU352)	Δp,PP,S,F,Dt,T,P	x	x	x	2			*9)	*9)	*9)	*9)	*9)	*9)	*9)	*9)				x	x	x	x	x	x	x	x	x	x
Control MPC series 2000 (CU352)	Δp,PP,S,F,Dt,T,P	x	x		2			*9)	*9)	*9)	*9)	*9)	*9)	*9)	*9)				x	x	x	x	x	x	x			
HydroMPC (CU352)	P	x	x		2			*9)	*9)	*9)	*9)	*9)	*9)	*9)	*9)				x	x	x	x	x	x	x	x	x	x
CUE (Frequency converter)	Δp,PP,S,F,Dt,T,P,L	x	x	*3)	x	2		*10)	*10)	*10)	*10)	*10)	*10)	*10)	*10)				x	x	x	x	x	x	x	x	x	x
MP204 (Motorprotection)		x			x	1	x		*10)	*10)															x	x	x	

A= Autoadapt, Dp= Differential Pressure, P= Const. Pressure, PP= Proportional Pressure, T= Const. Temperature, DT= Differential Temperature, F= Const Flow, S= Const. Speed/Frequency, L=Level, pH=pH-Wert, Cl2= Chlorine, ClO2=Chlorine dioxide, O3=Ozone, PAA=Peracetic acid, H2O2=Hydrogen peroxide, FA=FlowAdapt

- *1) MAGNA3 cascade up to 2 pumps without ext. controller
- *2) TPED
- *3) E-pumps MGE model H/I/J cascade up to 2 pumps, with external Control MPC cascade up to 6 pumps possible. Note: data point "heat energy" only on twinpump available.
- *4) All MGEs model H/I/J: 2 relays
- *5) MGE model H/I/J: CIM interfaces, TPED and MGE model F/G: CIU interfaces
- *6) version CIM xx2 needed
- *7) DDA Option E-Box Profibus
- *8) for GRM alternative solution: G501
- *9) CIM interfaces
- *10) CIU interfaces
- *11) incl. differential pressure sensor
- *12) 4-20 mA Sensor required x available

PB with roof tank		Features Pumps														Pumps												
Recommended product types: Pressure control	Control (depend on connected sensor)	single pump	duty / standby	parallel cascade operation	Non e-pump	Relay outputs	Grundfos GO communication	R100 Infrared communication	BACnet MS/TP or BACnet IP communication	LONWorks data communication	PROFIBUS DP/ PROFINET data communication	Modbus RTU data communication	EtherNet/IP data communication	Modbus TCP data communication	3C/4G cellular data communication	Gic/ GRM (Grundfos Remote Management) *8)	GENiBus data communication	Ethernet (VNC Server) data communication	No external sensor required	Sensor (0)4-20mA / 0-10V	Sensor installed over the pump	Sensor installed in the system	Analogue setpoint influence (0-10 V)	Grafic display with user interface	Start-up wizard	Motor protection	CR	CM
		E-pump CRE	P	x	x	*3)		*4)	x	x	*5)	*5)	*5)	*5)	*5)	*5)	*5)				x	x	x	x			x	
E-pump CRE (MGE model H/I/J)	P	x	x	x	*3)		2	x	x	*5)	*5)	*5)	*5)	*5)	*5)				x	x	x	x	x	x	x			
Hydro Multi-S	P	x				1																						
Hydro Multi-E	P	x	x			1	x		*10)	*10)	*10)	*10)		*10)	*10)				x	x	x	x			x			
Control MPC (CU352)	Δp,PP,S,F,Dt,T,P	x	x	x	2			*9)	*9)	*9)	*9)	*9)	*9)	*9)	*9)				x	x	x	x	x	x	x	x	x	x
Control MPC series 2000 (CU352)	Δp,PP,S,F,Dt,T,P	x	x		2			*9)	*9)	*9)	*9)	*9)	*9)	*9)	*9)				x	x	x	x	x	x	x			
HydroMPC (CU352)	P	x	x		2			*9)	*9)	*9)	*9)	*9)	*9)	*9)	*9)				x	x	x	x	x	x	x	x	x	x
CUE (Frequency converter)	Δp,PP,S,F,Dt,T,P,L	x	x	*3)	x	2		*10)	*10)	*10)	*10)	*10)	*10)	*10)	*10)				x	x	x	x	x	x	x	x	x	x
MP204 (Motorprotection)		x			x	1	x		*10)	*10)															x	x	x	

A= Autoadapt, Dp= Differential Pressure, P= Const. Pressure, PP= Proportional Pressure, T= Const. Temperature, DT= Differential Temperature, F= Const Flow, S= Const. Speed/Frequency, L=Level, pH=pH-Wert, Cl2= Chlorine, ClO2=Chlorine dioxide, O3=Ozone, PAA=Peracetic acid, H2O2=Hydrogen peroxide, FA=FlowAdapt

- *1) MAGNA3 cascade up to 2 pumps without ext. controller
- *2) TPED
- *3) E-pumps MGE model H/I/J cascade up to 2 pumps, with external Control MPC cascade up to 6 pumps possible. Note: data point "heat energy" only on twinpump available.
- *4) All MGEs model H/I/J: 2 relays
- *5) MGE model H/I/J: CIM interfaces, TPED and MGE model F/G: CIU interfaces
- *6) version CIM xx2 needed
- *7) DDA Option E-Box Profibus
- *8) for GRM alternative solution: G501
- *9) CIM interfaces
- *10) CIU interfaces
- *11) incl. differential pressure sensor
- *12) 4-20 mA Sensor required x available

5.4 TRANSPORT TO ROOF TANKS

When an application requires a rooftop speed controlled boostersystem can be beneficial in order to make sure that the filling of the tank takes place in a manner where the pipes are protected from waterhammer and pressure surges that in the end can result in pipebursts and noise.

Boostersystems that are used for tank filling should incorporate a fillingphase that slowly fills the pipe up and make s sure that the noise and surge from the start up of the pumps are kept at a minimum.

The Hydro Multi-B with dedicated tankfilling software gives the possibility to do excatly that.

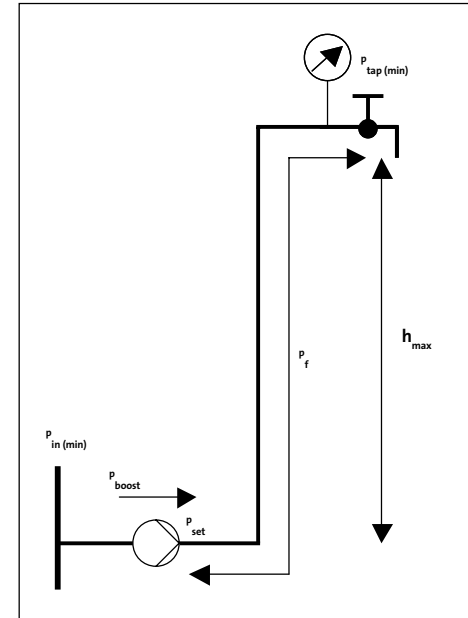

5.5 PB ZONE DEVIDED

Zones

In high rise buildings it is necessary to split the water supply system up in zones to ensure: that the pressure from one floor to an other doesn't vary too much. Min. pressure upper floor in each zone shouldnot be lower than 1.5-2 bar
Max. pressure in lowest floor in each zone should not be higher than 4-4.5 bar

System layout can be with :

1. All booster systems in basement. Boosting up in the building (see figure).
2. Cascade booster system layout. One booster in the basement supplies all the water up to zone 1, where a second booster will boost up to zone 2, etc.
3. In combination with roof tank.A booster on the roof top are boosting down to the 3-4 upper floors. The rest of the building is supplied by gravity.

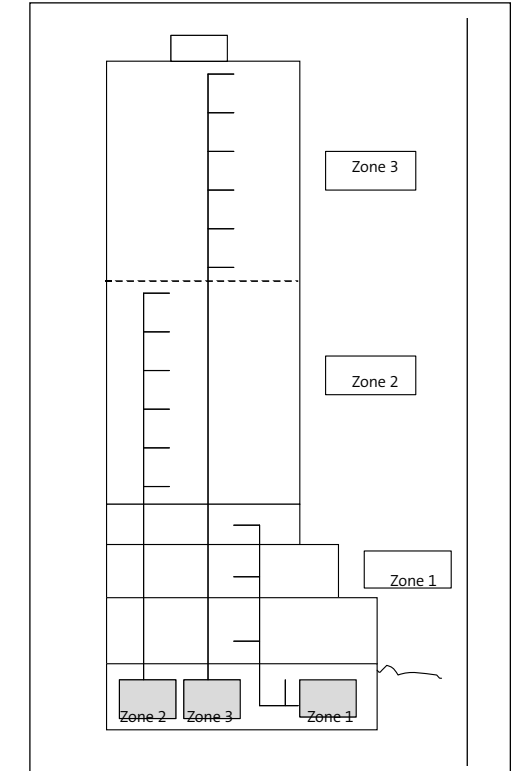

Transport to roof tank		Features Pumps																Pumps									
Recommended product types: Level control, pressure control	Control (depend on connected sensor)	single pump	parallel cascade operation	Non e-pump	Relay outputs	Grundfos GO communication	R100 Infrared communication	BACnet MS/TP or BACnet IP communication	LONWorks data communication	PROFIBUS DP/ PROFINET data communication	Modbus RTU data communication	EtherNet/IP data communication	Modbus TCP data communication	3G/4G cellular data communication	GiC/ GRM (Grundfos Remote Management) *8)	GENIBus data communication	Ethernet (VNC Server) data communication	No external sensor required	Sensor (0/4-20mA / 0-10V)	Sensor installed over the pump	Sensor installed in the system	Analogue setpoint influence (0-10 V)	Grafic display with user interface	Start-up wizard	Motor protection	CR	CM
		E-pump CRE	P	x	x	*3)		*4)	x	x	*5)	*5)	*5)	*5)	*5)	*5)	*5)			x	x	x	x	x	x	x	x
E-pump CRE (MGE model H/I/J)	P	x	x	x	*3)		2	x	x	*5)	*5)	*5)	*5)	*5)	*5)			x	x	x	x	x	x	x	x		
Hydro Multi-S	P	x				1																			x		
Hydro Multi-E	P	x	x			1	x		*10)	*10)	*10)	*10)	*10)	*10)	*10)	x		x	x	x	x	x	x	x	x		
Hydro Multi-B	P	x	x						*9)	*9)	*9)	*9)	*9)	*9)	*9)												
Control MPC (CU352)	Δp,PP,S,F,Dt,T,P	x	x	x	2				*9)	*9)	*9)	*9)	*9)	*9)	*9)	x		x	x	x	x	x	x	x	x	x	x
Control MPC series 2000 (CU352)	Δp,PP,S,F,Dt,T,P	x	x		2				*9)	*9)	*9)	*9)	*9)	*9)	*9)	x		x	x	x	x	x	x	x	x	x	
HydroMPC (CU352)	P	x	x		2				*9)	*9)	*9)	*9)	*9)	*9)	*9)	x		x	x	x	x	x	x	x	x	x	
CUE (Frequency converter)	Δp,PP,S,F,Dt,T,P,L	x	x	*3)	x	2			*10)	*10)	*10)	*10)	*10)	*10)	*10)	x		x	x	x	x	x	x	x	x	x	
MP204 (Motorprotection)		x			x	0	x	x		*10)	*10)	*10)	*10)	*10)	*10)	x									x	x	x

A= Autoadapt, Dp= Differential Pressure, P= Const. Pressure, PP= Proporational Pressure, T= Const. Temperature, DT= Differential Temperature, F= Const Flow, S= Const. Speed/Frequency, L=Level, pH=pH-Wert, Cl2= Chlorine, ClO2=Chlorine dioxide, O3=Ozone, PAA=Peracitic acid, H2O2=Hydrogen peroxide, FA=FlowAdapt

*1) MAGNA3 cascade up to 2 pumps without ext. controller
*2) TPED

*3) E-pumps MGE model H/I/J cascade up to 2 pumps, with external Control MPC cascade up to 6 pumps possible. Note: data point "heat energy" only on twinpump available.

*4) All MGEs model H/I/J: 2 relays
*5) MGE model H/I/J: CIM interfaces, TPED and MGE model F/G: CIU interfaces

*6) version CIM xx2 needed
*7) DDA Option E-Box Profibus

*8) for GRM alternative solution: G501

*9) CIM interfaces
*10) CIU interfaces
*11) incl. differential pressure sensor
*12) 4-20 mA Sensor required x available

PB zone devided		Features Pumps																Pumps									
Recommended product types: Pressure control	Control (depend on connected sensor)	single pump	parallel cascade operation	Non e-pump	Relay outputs	Grundfos GO communication	R100 Infrared communication	BACnet MS/TP or BACnet IP communication	LONWorks data communication	PROFIBUS DP/ PROFINET data communication	Modbus RTU data communication	EtherNet/IP data communication	Modbus TCP data communication	3G/4G cellular data communication	GiC/ GRM (Grundfos RemoteManagement) *8)	GENIBus data communication	Ethernet (VNC Server) data communication	No external sensor required	Sensor (0/4-20mA / 0-10V)	Sensor installed over the pump	Sensor installed in the system	Analogue setpoint influence (0-10 V)	Grafic display with user interface	Start-up wizard	Motor protection	CR	CM
		E-pump CRE	P	x	x	*3)		*4)	x	x	*5)	*5)	*5)	*5)	*5)	*5)	*5)					x	x	x	x	x	x
E-pump CRE (MGE model H/I/J)	P	x	x	x	*3)		2	x	x	*5)	*5)	*5)	*5)	*5)	*5)					x	x	x	x	x	x		
Hydro Multi-S	P	x				1																			x		
Hydro Multi-E	P	x	x			1	x		*10)	*10)	*10)	*10)	*10)	*10)	*10)	x		x	x	x	x	x	x	x	x		
Control MPC (CU352)	Δp,PP,S,F,Dt,T,P	x	x	x	2				*9)	*9)	*9)	*9)	*9)	*9)	*9)	x		x	x	x	x	x	x	x	x	x	x
Control MPC series 2000 (CU352)	Δp,PP,S,F,Dt,T,P	x	x		2				*9)	*9)	*9)	*9)	*9)	*9)	*9)	x		x	x	x	x	x	x	x	x	x	x
HydroMPC (CU352)	P	x	x		2				*9)	*9)	*9)	*9)	*9)	*9)	*9)	x		x	x	x	x	x	x	x	x	x	x
CUE (Frequency converter)	Δp,PP,S,F,Dt,T,P,L	x	x	*3)	x	2			*10)	*10)	*10)	*10)	*10)	*10)	*10)	x		x	x	x	x	x	x	x	x	x	x
MP204 (Motorprotection)		x			x	1	x	x		*10)	*10)	*10)	*10)	*10)	*10)	x									x	x	x

A= Autoadapt, Dp= Differential Pressure, P= Const. Pressure, PP= Proporational Pressure, T= Const. Temperature, DT= Differential Temperature, F= Const Flow, S= Const. Speed/Frequency, L=Level, pH=pH-Wert, Cl2= Chlorine, ClO2=Chlorine dioxide, O3=Ozone, PAA=Peracitic acid, H2O2=Hydrogen peroxide, FA=FlowAdapt

*1) MAGNA3 cascade up to 2 pumps without ext. controller
*2) TPED

*3) E-pumps MGE model H/I/J cascade up to 2 pumps, with external Control MPC cascade up to 6 pumps possible. Note: data point "heat energy" only on twinpump available.

*4) All MGEs model H/I/J: 2 relays

*5) MGE model H/I/J: CIM interfaces, TPED and MGE model F/G: CIU interfaces

*6) version CIM xx2 needed
*7) DDA Option E-Box Profibus
*8) for GRM alternative solution: G501

*9) CIM interfaces
*10) CIU interfaces
*11) incl. differential pressure sensor
*12) 4-20 mA Sensor required x available

5.B. RAINWATER

MEDIUM/ LARGE BUILDINGS

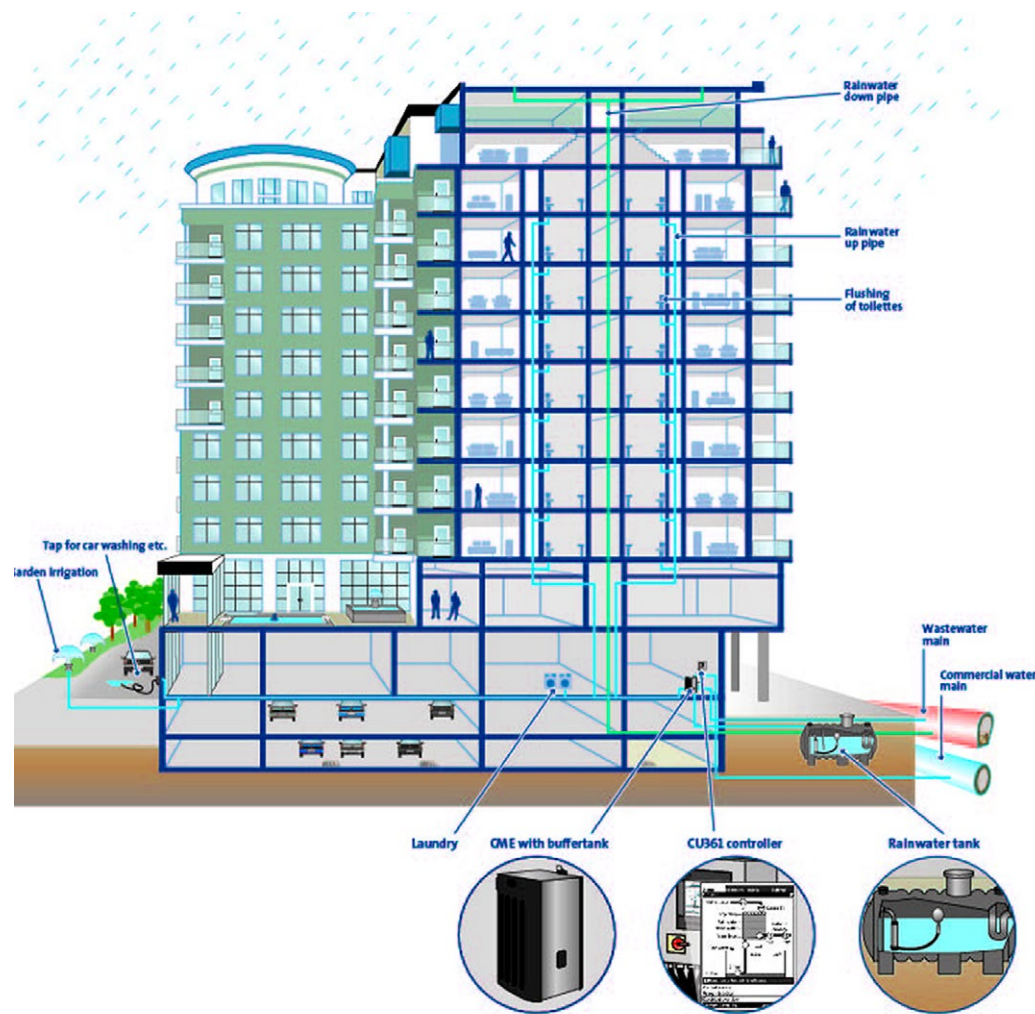

A well-designed rainwater harvesting system integrates several design disciplines, including civil, mechanical and electrical engineering, architecture and landscape architecture, toward the common goal of using one of nature's most renewable resources. Depending on the application, rainwater becomes the sole or partial source of water for water closets and urinals, landscape irrigation, hose bibs, water features, cooling towers or secondary fire suppression. From a building owner's perspective, rainwater harvesting offers the opportunity to decrease water and wastewater costs, which are rising faster than energy costs in some parts of the countries. It can ease the burden of system development charges that often are assessed on new buildings to help pay for expanding municipal infrastructure and separate storm water management systems.

Rainwater harvesting also can turn a potential liability—runoff and resulting erosion—into an asset.

Perhaps the best and most prevalent reason, for integrating rainwater harvesting into a new building's design is increasing interest in green building. Rainwater harvesting is a relatively easy and excellent way to demonstrate environmental stewardship to the community and stakeholders. And, depending on the design, rainwater harvesting can help a project garner up to achieve points toward the U.S. Green Building Council's Leadership in Energy and Environmental Design (LEED) rating, making it easier to achieve LEED Silver, Gold or Platinum levels.



5.B.1 RAINWATER CONTROL

Reliability

Absence of multistage centrifugal self-priming pumps. Their absence can overcome all the problems or the suction lines are likely to suffer. In addition, the designer of the building will not be considered to be constrained by laws that restrict the hydraulic suction pump self-priming up to MWK 10.33. (Note: This value corresponds to the maximum height; it should be corrected according to the dynamic pressure drop and NPSH value (net positive suction) of the pump)

Energy efficiency

Very important, especially in case of shortage of rainfall and water use necessary potable. The standard EN1717 and guidelines in this area clearly state that the pressure of the water should be reduced to atmospheric pressure before being again brought to its pressure by a pump. In large buildings dimensions characterized by the presence of many sampling points does not require the distribution of drinking water, farmers often face a shortage of rainfall.

User friendly and easy to set

The installation is done through Grundfos RCME graphic display (CU 372). The range of Grundfos Hydro booster blowers MPC and consoles Dedicated Control Controls pumps for waste water have also this proven technology.



Synthesis

Designed to supply rainwater sampling points installed in the non-residential buildings and does not require the distribution of drinking water, this Grundfos offers is under the sign of reliability, energy efficiency and operational safety. If this system has no self-priming pump to prevent any problems likely to affect the suction (air pockets, irregular slope of the pipe, etc.), however it is equipped with a pump power of steel stainless steel tank connected to a rainwater tank hybrid. In case of shortage of rainfall, the system switches to the installation of water potable. This constant pressure pump and control the rotation speed has a high efficiency motor that provides water sampling points.

Rainwater harvesting		Features Pumps														Pumps											
Recommended product types: Rainwater control	Control (depend on connected sensor)	single pump	parallel cascade operation	Non e-pump	Relay outputs	Grundfos GO communication	R100 Infrared communication	BACnet data communication	LONworks data communication	PROFIBUS DP/ PROFINET communication	Modbus data communication	EtherNet/IP data communication	Modbus TCP data communication	3G/4G cellular data communication	GiC/ GRM data communication (Grundfos Remote Management)	GENibus data communication	Ethernet (VNC Server) data communication	No external sensor required	Sensor (0)4-20mA / 0-10V	Sensor installed over the pump	Sensor installed in the system	Analogue setpoint influence (0-10 V)	Graphic display with user interface	Start-up wizard	Motor protection	SPO (feed pump)	CME
		RCME	P	x			2										*9)	*9)	x	x	x	x	x	x	x	x	x

A= Autoadapt, Dp= Differential Pressure, P= Const. Pressure, PP= Proportional Pressure, T= Const. Temperature, DT= Differential Temperature, F= Const Flow, S= Const. Speed/Frequency, L=Level, pH=pH-Wert, Cl2= Chlorine, ClO2=Chlorine dioxide, O3=Ozone, PAA=Peracetic acid, H2O2=Hydrogen peroxide, FA=FlowAdapt

*1) MAGNA3 cascade up to 2 pumps without ext. controller
 *2) TPED
 *3) E-pumps MGE model H/I/J cascade up to 2 pumps, with external Control MPC cascade up to 6 pumps possible. Note: data point "heat energy" only on twin pump available.
 *4) All MGEs model H/I/J: 2 relays

*5) MGE model H/I/J: CIM interfaces, TPED and MGE model F/G: CIU interfaces
 *6) version CIM xx2 needed
 *7) DDA Option E-Box Profibus
 *8) for GRM alternative solution: G501

*9) CIM interfaces
 *10) CIU interfaces
 *11) incl. differential pressure sensor
 *12) 4-20 mA Sensor required x available

6. WASTEWATER

MEDIUM/ LARGE BUILDINGS

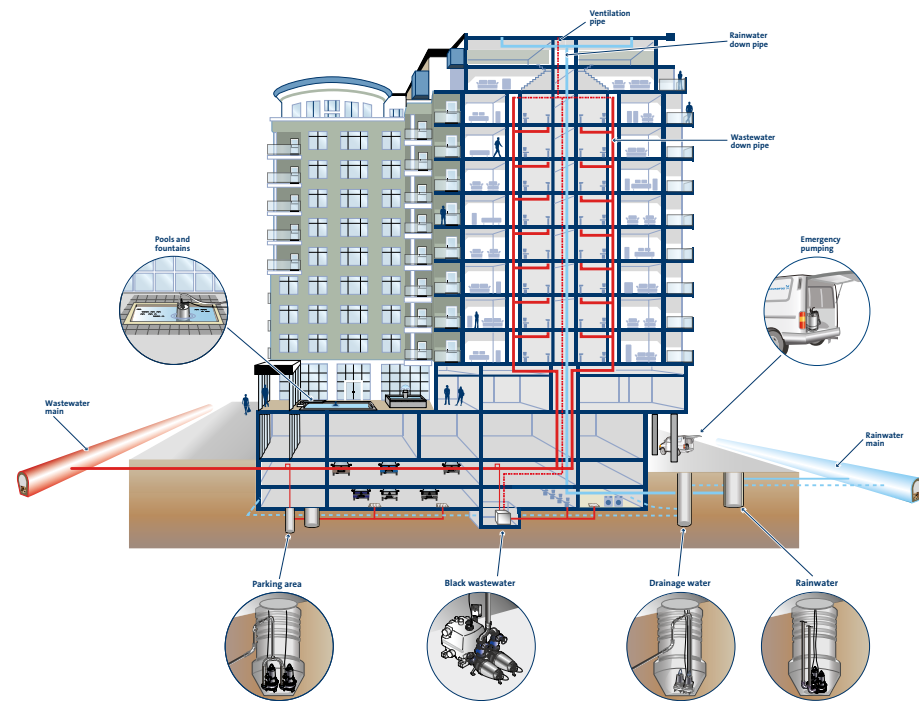

Wastewater in building, especially in commercial building need to be collected and discharged to the main sewer systems outside the building when sanitary appliances, cantines, backwashfilter from swimming pools, drainage, deep-level garages etc. are located in the basements below the sewer system outside. The must to effluent these sections of the buildings is beyond dispute. Wastewater from a building is divided into blackwater with faeces from toilets and greywater w/o faeces e.g. from washing machines, showers, wash basins etc.. And in close connections to the building also drainage-, surface- and rainwater need to be collected. That must happen outside the building in pumping stations and not be led into the building. The portfolio of solutions is wide for single sanitary appliances up to dewater whole basement installations with e.g. cantines, rest rooms and/or spa areas. Pump solutions in buildings can be implemented as single or double pump units in concrete wells inside the basement plate, ready to install lifting stations with a composite or polyethylen collecting tank with pumps, level detection and controller pre-assembled or in pumping stations outside the building.

One pump solutions with a level switch or a small control device are premilary used for domestic applications in single family houses or light commercial use when wastewater transport can be interrupted in case of service, maintenance or failure. For more security an alarm device or a controller with separate level detection and several alarm indications (min. a high water level alarm) is recommended.

For most of commercial applications wastewater transport isn't allowed to be interrupted. Grundfos recommend double pump units with level detection and controller to get the best security level for building investments. That contains

- parallel operation of both pumps in case of high peak inflow
- changeover in normal operation mode to get same runtimes for both pumps
- fault changeover to the other pump to secure continous wastewater transport
- high water level alarm

For more useful functions see controller section.

* It is not recommended to use a PS station with a grinder for drainage or surface water.

Type of wastewater	Pumps			Lifting Stations		Pumping Stations
	Unilift	DP/EP	SEL, SEV, SEG	Uno/Duolift	Multilift-Series	Grundfos Pumping Stations
Drainage water	✓	✓	✓			✓*
Grey water	✓	✓	✓	✓	✓	✓
Black water			✓	✓	✓	✓
Surface water	✓	✓	✓			✓*

6.1 WASTEWATER FROM BASEMENT

Submersible wastewater pumps:

UNILIFT (up to 1,5kW) - are available with level switch for automatic start and stop. Or without for usage of a separate level detection and controller. They can be installed in customized concrete wells in the basement plate or special collecting tanks like Liftaway C, Liftaway B, Uno-/Duolift and Grundfos Pumping Stations.

DP, EF and small SL (up to 1,5kW) - are available as a complete stand-alone solution (AutoAdapt) with build-in level transmitter, motor protections and control unit. They are also available as traditional pumps which require a separate level detection and control unit. They are intended for submersible installation in concrete or pre-fabricated pumping stations.

SEG (grinder pump up to 4kW) - are e or pre-fabricated pumping stations available as a complete stand-alone solution (AutoAdapt) with build-in level transmitter, motor protections and control unit. They are also available as traditional pumps which require a separate level detection and control unit. They are intended for submersible installation in concrete.

SE and SL (up to 30kW) - are available as traditional pumps which require a separate level detection and control unit. They are intended for dry-installation (SE) or submersible installation (SL) in concrete or pre-fabricated pumping stations.

Pre-assembled lifting stations:

SOLOLIFT2 - are designed for a limited number of sanitary appliances (e.g. single toilet, wash basin, shower). All SOLOLIFT2 are

available with a collecting tank, a pump unit, level switch and control device for start and stop. An additional alarm PCB can be ordered. A choice of external controller is not needed.

MULTILIFT - are designed to dewater areas or complete basements. They are supplied as complete units consisting of a collecting polyethylen tanks (66-1350 litre) , one or two pumps, non-return valve(s) and a level sensor connected to a controller LC220 or LC221. Delivered complete pre assembled and ready for installation. A choice of external controller is not needed.

UNO-/DUOLIFT - are designed to dewater areas or complete basements. They are supplied as complete units consisting of a collecting polyethylen tanks (270 and 540 litre) , one or two submersible pumps inside (UNILIFT, SEG, small SL) and a level switches connected to a LC(D) controller. A choice of external controller is not needed.

Pumping stations:

PS - are designed to dewater complete buildings up to whole districts depending on the size. They are supplied customized, complete units consisting of a collecting well (300 - 2000 litre) , one or two pumps, complete pipework with non-return valve(s), a level sensor connected to a controller which need to be selected due to application and the the pump type and size.

LC/LCD 115 Controllers with level transmitter:

For liquid level control in drainage applications and wastewater pump pits.

Wastewater from basement		Features Pumps														Pumps																				
Recommended product types: Level control	Control (depend on connected sensor)	single pump	double pump (duty / standby)	parallel cascade operation	Non e-pump	Relay outputs	Grundfos GO communication	R100 Infrared communication	BACnet data communication	LONWorks data communication	PROFIBUS DP/PROFINET data communication	Modbus RTU data communication	EtherNet/IP data communication	Modbus TCP data communication	3G/4G cellular data communication	GiC / GRM data communication (Grundfos Remote Management)	GENIBus data communication	Ethernet (VNC Server) data communication	No external sensor required	Sensor (0)4-20mA / 0-10V	Sensor installed over the pump	Sensor installed in the system	Analogue setpoint influence (0-10 V)	Grafic display with user interface	Start-up wizard	Motor protection	UNILIFT CC, KP, AP	Small SL / DP/ EF/ SEG (w/o AutoAdapt3)	SE, SL, S	MULTILIFT	UNO-/DUOLIFT					
		MULTILIFT with Controller	L	x	x	x	x	4-6												x						x	x	x	x							
DP,EF, small SL / SEG with AutoAdapt	A	x	x	x	x	1	x	*10			*6	*6			*6	*6	*6	x								x		x								
LC / LCD 107	L	x	x	x	x	2												x								x	x	x	x							
LC / LCD 108	L	x	x	x	x	2													x							x	x	x	x							
LC / LCD 110	L	x	x	x	x	2														x						x	x	x	x							
LC / LCD 115	L	x	x	x	x	2														x						x	x	x	x							
Control DC (Dedicated Controls)	L	x	x	x	x	2				*9	*9		*9	*9	*9	*9	x					x	x	x	x	x	x	x	(x)	x		(x)				
MP204 (Motor protection)		x				1	x	x		*10	*10		*10	*10	*10	*10	x										x		(x)	x						
IO113 signal converter		x																																		
SM 113		x																																		

A= Autoadapt, Dp= Differential Pressure, P= Const. Pressure, PP= Proporational Pressure, T= Const. Temperature, DT= Differential Temperature, F= Const Flow, S= Const. Speed/Frequency, L=Level, pH=pH-Wert, Cl2= Chlorine, ClO2=Chlorine dioxide, O3=Ozone, PAA=Peracetic acid, H2O2=Hydrogen peroxide

*6) version CIU xx2 needed
*7) DDA Option E-Box Profibus
*8) GENIBusmodule MPC

*9) CIM interfaces
*10) CIU interfaces
*11) incl. differential pressure sensor

*12) 4-20 mA Sensor required
x available

6.2 DRAINAGE

When installed permanently in a pump pit, the pumps are typically used for drainage and pumping effluent from cellars, air handling units, boiler rooms, elevator shafts or other situations where water is unwanted in and around buildings. In drainage systems the min. free passage for the pump must not be less than 5 -10 mm.

The Unilift KP and Unilift AP pump range is ideal for permanent installation in the Liftaway B pump pits and allows for a very fast and flexible installation. With a flow switch connected, the pump can be used for automatic operation.

For larger quantities of drainage water the range of Grundfos DP and DPK pumps can meet virtually all systems in and around buildings. The most common used installation is submerged into position on guide rails, and it automatically connects with the discharge pipe system.

To prevent backflow, a non-return valve is normally installed in connection with the system.

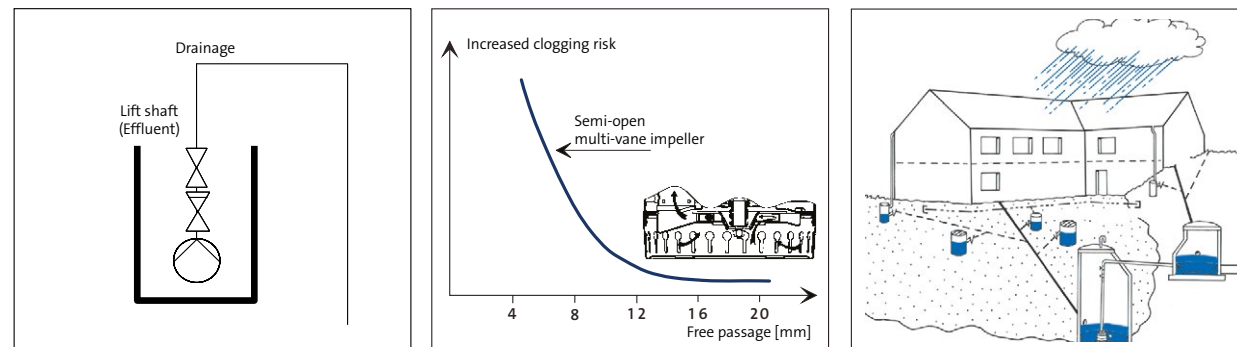

6.3 SURFACE WATER

Rain water from catchment areas of the building is in most cases gathered in a pit. Often there is a need for a pump to pump the water into the municipality rainwater system. The amount of drainage collected depends on both the vertical area of the building as well as the roof and gravel area surrounding the building incl. parking areas and gardens. In rain water systems the min. free passage for the pump must not be less than 25 – 30 mm.

Pump failure in rain water systems will normally cause heavy expenses for considerable cleaning and disinfection before drying-out can take place. Therefore we recommend 100% spare capacity in the system.

Common to all the variants in the Grundfos pump range is their easy-to-install design. The Unilift KP and Unilift AP pump range is ideal for permanent installation in pump pits and allows for a very flexible installation. With a flow switch connected, the pump can be used for automatic operation.

For larger quantities of surface water the range of Grundfos EF, SL, SE, S Pumps can meet virtually all systems in and around buildings.

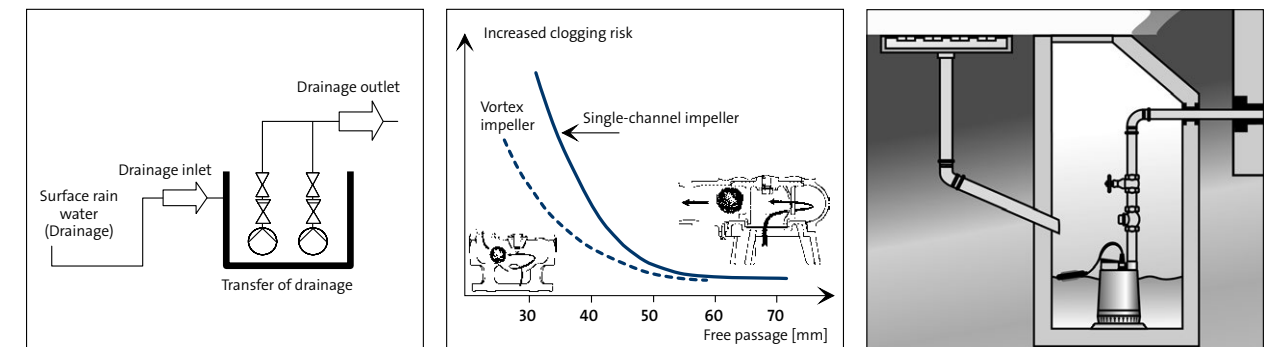

Drainage		Features Pumps														Pumps												
Recommended product types: Level control	Control (depend on connected sensor)	single pump	double pump (duty / standby)	parallel cascade operation	Non e-pump	Relay outputs	Grundfos GO communication	R100 Infrared communication	BACnet data communication	LONWorks data communication	PROFIBUS DP/ PROFINET data communication	Modbus RTU data communication	EtherNet/IP data communication	Modbus TCP data communication	3G/4G cellular data communication	GiC/ GRM data communication (Grundfos Remote Management)	GENIBUS data communication	Ethernet (VNC Server) data communication	No external sensor required	Sensor (0)4-20mA / 0-10V	Energy optimizing functions	Grafic display with user interface	Start-up wizard	Motor protection	DP, DPK, EF, SL, SE	Unilift AP/KP/CC	DP, EF, SL AUTOADAPT	
		CUE (Frequency converter)	Δp, PP, S, F, Dt, T, P, L	x	x	*3	x	2			*10	*10	*10	*10	*10	*10	*10	*10	x			x	x	x	x	x	x	
Control DC (Dedicated Controls)	L	x	x	x	x	2				*9	*9	*9	*9	*9	*9	*9	x			x	x	x	x	x	x			
LLC 1000W	L	x																										x
LC/ LCD	L	x	x	x	x	2													x				x	x	x	x		
MP204 (Motor protection)		x			x	1	x	*10		*10	*10	*10	*10	*10	x								x	x	x			
IO113 signal converter		x																						x	x			
WW AUTOADAPT	L	x	x	x		1			*6	*6	*6	*6	*6	*6	*6	*6	x		x				x	x			x	

A= Autoadapt, Dp= Differential Pressure, P= Const. Pressure, PP= Proportional Pressure, T= Const. Temperature, DT= Differential Temperature, F= Const Flow, S= Const. Speed/Frequency, L=Level, pH=pH-Wert, Cl2= Chlorine, ClO2=Chlorine dioxide, O3=Ozone, PAA=Peracetic acid, H2O2=Hydrogen peroxide

- *6) version CIU xx2 needed
- *7) DDA Option E-Box Profibus
- *8) GENIBUSmodule MPC
- *9) CIM interfaces
- *10) CIU interfaces
- *11) incl. differential pressure sensor
- *12) 4-20 mA Sensor required
- *13) prepared for CIM interface, profiles follow later
- x available

Surface water		Features Pumps														Pumps												
Recommended product types: Level control	Control (depend on connected sensor)	single pump	double pump (duty / standby)	parallel cascade operation	Non e-pump	Relay outputs	Grundfos GO communication	R100 Infrared communication	BACnet data communication	LONWorks data communication	PROFIBUS DP/ PROFINET data communication	Modbus RTU data communication	EtherNet/IP data communication	Modbus TCP data communication	3G/4G cellular data communication	GiC/ GRM data communication (Grundfos Remote Management)	GENIBUS data communication	Ethernet (VNC Server) data communication	No external sensor required	Sensor (0)4-20mA / 0-10V	Energy optimizing functions	Grafic display with user interface	Start-up wizard	Motor protection	EF, SL, SE, S	Unilift AP/KP/CC	EF, SL AUTOADAPT	
		CUE (Frequency converter)	Δp, PP, S, F, Dt, T, P, L	x	x	*3	x	2				*10	*10	*10	*10	*10	*10	*10	x			x	x	x	x	x	x	
Control DC (Dedicated Controls)	L	x	x	x	x	2					*9	*9	*9	*9	*9	*9	x			x	x	x	x	x	x			
LC/ LCD	L	x	x	x	x	2																	x	x	x			
MP204 (Motor protection)		x			x	1	x	x			*10	*10	*10	*10	*10	x								x	x			
IO113 signal converter		x																							x			
WW AUTOADAPT	L	x	x	x		1	x	*6			*6	*6	*6	*6	*6	*6	x		x				x	x			x	

A= Autoadapt, Dp= Differential Pressure, P= Const. Pressure, PP= Proportional Pressure, T= Const. Temperature, DT= Differential Temperature, F= Const Flow, S= Const. Speed/Frequency, L=Level, pH=pH-Wert, Cl2= Chlorine, ClO2=Chlorine dioxide, O3=Ozone, PAA=Peracetic acid, H2O2=Hydrogen peroxide

- *6) version CIU xx2 needed
- *7) DDA Option E-Box Profibus
- *8) GENIBUSmodule MPC
- *9) CIM interfaces
- *10) CIU interfaces
- *11) incl. differential pressure sensor
- *12) 4-20 mA Sensor required
- x available

6.4 SEWAGE

Pumping stations are designed for collecting and pumping sewage and effluent from discharge levels below the sewer line. The Super Vortex hydraulic is specially designed to handle unscreened sewage and its performance is superior in situations where small volumes of flow are pumped against high heads. For larger volumes channel hydraulics is normally used.

The range of Grundfos SEG, SL, SE, S Wastewater Pumps is used for pumping sewage, wastewater and considerable quantities of surface water and ground water.

Pump failures in a sewage system may additionally result in evacuation and rehousing of people, due to contamination. Therefore we recommend always to have 100% spare capacity in the system.

For larger quantities of wastewater the most common used installation is submerged in a pumping station, where the pump is lowered into position on guide rails, and it automatically connects with the discharge pipe system.

If space is available, the pumps can also be installed either vertically or horizontally, in dry rooms.

Grundfos offer a wide range of PS pre-fabricated pumping station, for this purpose. Sewage pumps in common systems are frequently operated in parallel to enhance output.

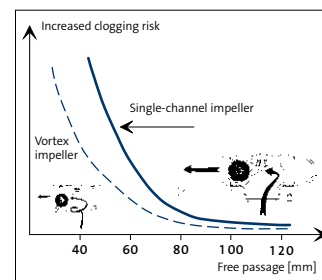
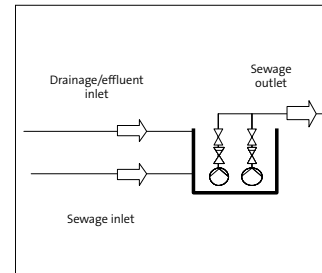

6.5 DEWATERING

For emptying of smaller tanks, ponds and pools the lightweight composite Unilift CC or stainless steel range of Unilift KP, Unilift AP and DP pumps are very easy to handle and install.

For larger quantities of drainage water, and more demanding applications like excavation of construction sites for larger buildings, or flooded basements, the range of Grundfos DP, DPK, DWK pumps can meet virtually all demands in and around buildings.

The vertical discharge port at the top of the pumps allows for quick installation. The pump range is ideal for temporary as well as permanent installation, and allows for vertical, horizontal or even inclined installation.

In the systems the min. free passage for the pump must not be less than 10 mm.

With a flow switch connected, the pump can be used for automatic operation. The DW pumps offers own integrated automatic start-stop system. To prevent backflow, a non-return valve is normally installed in connection with the system.

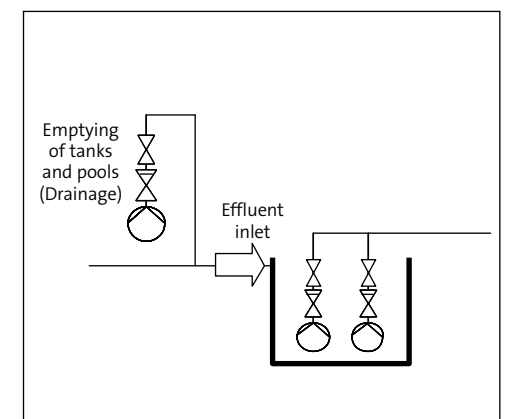

Sewage		Features Pumps																Pumps									
Recommended product types: Level control	Control (depend on connected sensor)	single pump	double pump (duty / standby)	parallel cascade operation	Non e-pump	Relay outputs	Grundfos GO communication	R100 Infrared communication	BACnet data communication	LONWorks data communication	PROFIBUS DP/ PROFINET data communication	Modbus RTU data communication	EtherNet/IP data communication	Modbus TCP data communication	3C/4G cellular data communication	GIC/ GRM data communication (Grundfos Remote Management)	GENibus data communication	Ethernet (VNC Server) data communication	No external sensor required	Sensor (0)4-20mA / 0-10V	Energy optimizing functions	Graphic display with user interface	Start-up wizard	Motor protection	SEG, SL, SE, S	SEG, SL-AUTOADAPT	
		Multilift	L	x	x	x	x	4																			
CUE (Frequency converter)	Δp,PP,S,F,Dt,T,P,L	x	x	*3	x	2			*10	*10	*10	*10	*10	*10	*10	*10	x			x	x	x	x	x	x	x	x
Control DC (Dedicated Controls)	L	x	x	x	x	2					*9	*9		*9	*9	*9											
LC/ LCD	L	x	x	x	x	2																					
MP204 (Motor protection)		x			x	1	x	x			*10	*10		*10	*10	*10	x										
IO113 signal converter		x																									
WW AUTOADAPT	L	x	x	x		1	x	*6			*6	*6		*6	*6	*6	*6	x									

A= Autoadapt, Dp= Differential Pressure, P= Const. Pressure, PP= Proportional Pressure, T= Const. Temperature, Dt= Differential Temperature, F= Const Flow, S= Const. Speed/Frequency, L=Level, pH=pH-Wert, Cl2= Chlorine, ClO2=Chlorine dioxide, O3=Ozone, PAA=Peracetic acid, H2O2=Hydrogen peroxide

- *6) version CIU xx2 needed
- *7) DDA Option E-Box Profibus
- *8) GENibusmodule MPC
- *9) CIM interfaces
- *10) CIU interfaces
- *11) incl. differential pressure sensor
- *12) 4-20 mA Sensor required
- x available

Dewatering		Features Pumps																Pumps									
Recommended product types: Level control	Control (depend on connected sensor)	single pump	double pump (duty / standby)	parallel cascade operation	Non e-pump	Relay outputs	Grundfos GO communication	R100	BACnet data communication	LONWorks data communication	PROFIBUS DP/ PROFINET data communication	Modbus RTU data communication	EtherNet/IP data communication	Modbus TCP data communication	3C/4G cellular data communication	GIC/ GRM data communication (Grundfos Remote Management)	GENibus data communication	Ethernet (VNC Server) data communication	No external sensor required	Sensor (0)4-20mA / 0-10V	Energy optimizing functions	Graphic display with user interface	Start-up wizard	Motor protection	DP, DPK, DW, DWK	Unilift AP/KP/CC	DP AUTOADAPT
		CUE (Frequency converter)	Δp,PP,S,F,Dt,T,P,L	x	x	*3	x	2					*10	*10	*10	*10	*10										
Control DC (Dedicated Controls)	L	x	x	x	x	2					*9	*9	*10		*9	*9											
LC/ LCD	L	x	x	x	x	2																					
MP204 (Motor protection)		x			x	1	x	x			*10	*10	*10		*10	*10											
WW AUTOADAPT	L	x	x	x		1	x	*6			*6	*6	*6	*6	*6	*6	x										

A= Autoadapt, Dp= Differential Pressure, P= Const. Pressure, PP= Proportional Pressure, T= Const. Temperature, Dt= Differential Temperature, F= Const Flow, S= Const. Speed/Frequency, L=Level, pH=pH-Wert, Cl2= Chlorine, ClO2=Chlorine dioxide, O3=Ozone, PAA=Peracetic acid, H2O2=Hydrogen peroxide

- *6) version CIU xx2 needed
- *7) DDA Option E-Box Profibus
- *8) GENibusmodule MPC
- *9) CIM interfaces
- *10) CIU interfaces
- *11) incl. differential pressure sensor
- *12) 4-20 mA Sensor required
- x available

7. FIRE

MEDIUM/ LARGE BUILDINGS

Beyond standard products

Grundfos provides top performance electric - and diesel firepump systems with all relevant listings and approvals. The fire pump sets are tested thoroughly to ensure maximum performance and premium reliability. Grundfos has the widest range of firepumps, covering the Fire pump approvals globally i.e. FM, UL, VDS, LPCB, VNIIPPO, CCCF, EN 12845, OKF, PAVUS, CNBOP etc. etc.

Fire pump ranges

Our quick delivery programme contains more than the electrically or diesel-driven End Suction and Horizontal Split Case pumps. We also supply: In-Line fire pumps * Vertical turbine pumps (for wet pit applications, or applications where positive inlet pressure is not available).

Modularised systems

Grundfos designs and builds customised systems that meet your specific needs. We mount the fire pump, driver, controller and piping with complete interconnected wiring on a common base or a modularised base frame for final assembly on location.

Packaged / containerised systems

With Grundfos' enclosed systems, your installation-to-operation time is minimal. Our enclosed systems are typically built as an integrated pump and control centre with:

- Diesel engine
- All the required controllers
- In-house piping
- Fittings
- Interconnected wiring
- A complete installation that meets the requirements of UL, FM, NFPA 13 and NFPA 20

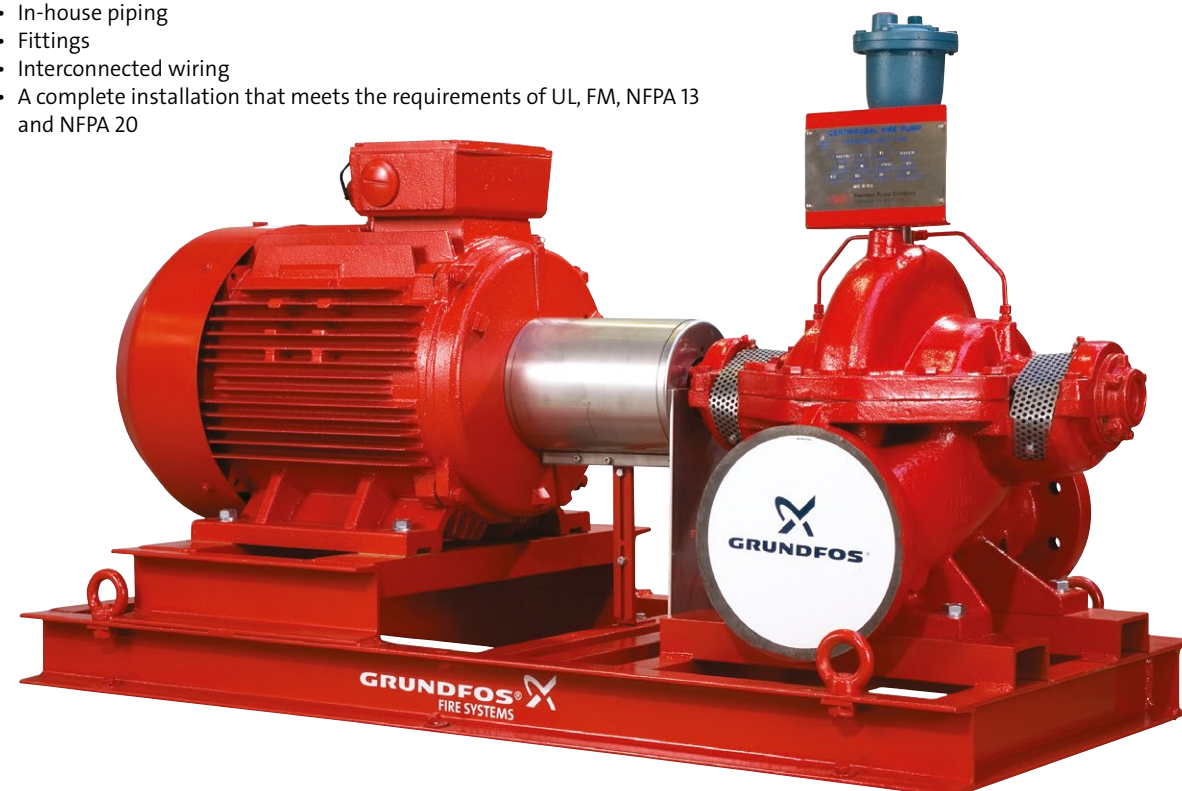

7.1 JOCKEY PUMP

The Jockey pump is activated by a signal from the pressure switch, to maintain the pressure in the pipesystem.

Standard CR pump, that are activated by pressure switch.

3 different controller alternatives :

- Controlled by the - Electric fire pump controller "VDS Control FS1" (optional feature in this sprinkler pump controller)
- Controlled by a separate standard pump controller "Hydro Mono"
- Controlled by a separate special Jockey pump controller "Control CS 1" From 0,75 - 18,5 kW - this is a special jockey pump controller with features: runtime, power, run, error indicators, start/test set.

7.2 Hydrant Pump systems

Beyond standard products

Grundfos provides fire pump systems for hydrants/ hose reel systems. The firepumps can be CR - or NB/NK pumps including controller compliant to local standards.



7.3 Sprinkler Pump systems

Grundfos provides Fire pump systems to automatic sprinkler systems. The Fire pumps can be NBF, NKF, DNF, HSEF, HSM and VTF including controllers compliant to local standards.

Electric Firepump controllers

- Control FS 1 Electric - approved by VdS
- Hydro MX Electric controller - approved by VNIIPPO (Russia)
- LPC Electric controller – compliant to BS EN 12845
- EN 12845 electric controller - compliant to EN 12845
- NFPA 20 Electric controller – approved by UL FM
- DBI 251 Electric controller – approved by DBI

Diesel Firepump controllers

- Control FS 1 Diesel - approved by VdS
- EN 12845 Diesel controller HIGH SPEC - approved by ANPI - NEW
- EN 12845 Diesel controller – approved by APSAD - NEW
- EN 12845 Diesel controller - compliant to EN 12845
- NFPA 20 Diesel Firepump controller – approved by UL FM
- LPC Diesel controller – approved by LPC
- DBI 251 Diesel controller – approved by DBI

For details of analog and digital signals and available data communication or GRM as accessory please ask your fire control cabinet builder (e.g GWP, GMR, GBW)

8. CONST PRESSURE – SPEED CONTROLLED OR ON/OFF REGULATED

INDUSTRY



Consumption patterns vary from one industry to the next. Some require frequent use of water in smaller amounts while others need to fill several large tanks in no time – without it affecting the water supply in different parts of the building. Grundfos' extensive range of utility pumps have been carefully developed to ensure constant pressure at all times in water supply applications.

Depending on your specific application, our reliable pumps can be customised to provide the exact pressure required. Single-stage and multistage pumps are available to guarantee constant pressure in critical or demanding applications. Multi pump systems can be delivered complete with VFDs and controls.

8.1 CONST PRESSURE

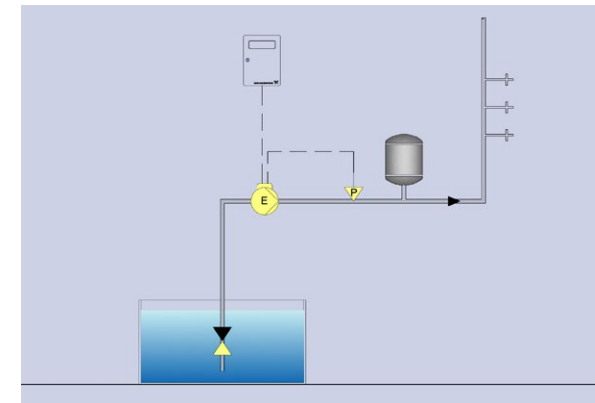

Single pump control
Constant Pressure - speed control:
(The function is described in details in the Grundfos Pump Handbook)

Pump will operate with constant pressure from Q_{min} to Q_n . From zero flow to Q_{min} the system will operate in On/Off mode by use of an attached tank.
Surveillance and monitoring can be attached i.e.
- Dry run protection
- Protection against closed valve
- Protection against busted pipe
- e.t.c.

Remote / Satellite operations is possible if needed. (Several Fieldbus standards are supported and also the GRM (Grundfos Remote Monitoring), e.t.c.)

8.2 ON/OFF PRESSURE CONTROL

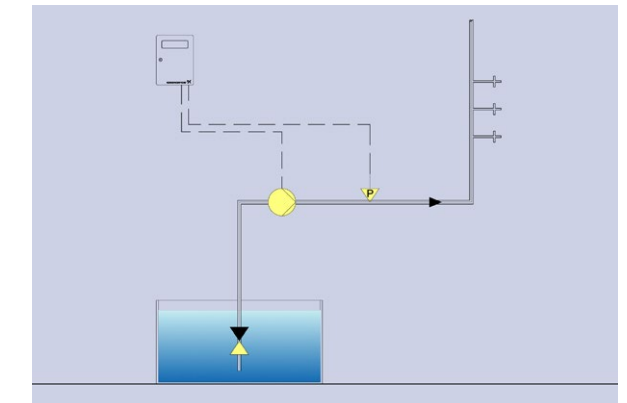

On/off pressure control:
By means of pressure switch, connected to a relay, and MP204 motor protection unit we have an operation, protection and surveillance in one package.
This can be used for monitoring of pumps in remote areas or for advanced control of large pumps in demanding applications.

Const pressure		Features														Pumps									
Recommended product types: Pressure control, flow control	Control (depend on connected sensor)	single pump	parallel cascade operation	Non e-pump	Relay outputs	Grundfos GO communication	R100 Infrared communication	BACnet data communication	LONWorks data communication	PROFIBUS DP/ PROFINET data communication	Modbus RTU data communication	EtherNet/IP data communication	Modbus TCP data communication	3G/4G cellular data communication	GiC/ GRM (Grundfos Remote Management)	GENIBUS data communication	Ethernet (VNC Server) data communication	No external sensor required	Sensor (0/4-20mA / 0-10V)	Analogue setpoint influence (0-10 V)	Graphic display with user interface	Start-up wizard	Motor protection	CR	CM
		E-pump CRE, CME	P	x	x	*3)	*4)	x	x	*5)	*5)	*5)	*5)	*5)	*5)	*5)	*5)	*5)			x	x			x
E-pump CRE (MGE model H/I/J)	P	x	x	x*3)	2	x	x	*5)	*5)	*5)	*5)	*5)	*5)	*5)	*5)	*5)			x	x	x	x	x	x	
Control MPC (CU352)	$\Delta p, PP, S, F, Dt, T, P$		x	x	2			*9)	*9)	*9)	*9)	*9)	*9)	*9)	*9)	*9)	x		x	x	x	x	x	x	x
CUE (Frequency converter)	$\Delta p, PP, S, F, Dt, T, P, L$	x	x	*3)	x	2		*10)	*10)	*10)	*10)	*10)	*10)	*10)	*10)	*10)	x		x	x	x	x	x	x	x
Control MP204 + IO112	$\Delta p, F, Dt, T, P$			x	1					*10)	*10)		*10)	*10)	*10)								x	x	x
MP204 (Motorprotection)		x			x	1	x	x		*10)	*10)		*10)	*10)	*10)	x							x	x	x

A= Autoadapt, Dp= Differential Pressure, P= Const. Pressure, PP= Proportional Pressure, T= Const. Temperature, Dt= Differential Temperature, F= Const. Flow, S= Const. Speed/Frequency, L=Level, pH=pH-Wert, Cl2= Chlorine, ClO2=Chlorine dioxide, O3=Ozone, PAA=Peracetic acid, H2O2=Hydrogen peroxide, FA=FlowAdapt

*1) E-pumps (MGE model H) + MAGNA3 cascade up to 2 pumps without ext. controller
*2) TPED
*3) E-pumps MGE model H/I/J cascade up to 2 pumps, with external Control MPC cascade up to 6 pumps possible. Note: data point "heat energy" only on twinpump available.

*4) MGE 3kW 2p./ 2,2kW 4.p -7,5 kW: 1 relay, 11-22kW: 2 relays
*5) MGE model H/I/J: CIM interfaces, TPED and MGE model F/G: CIM interfaces
*6) version CIM xx2 needed
*7) DDA Option E-Box Profibus

*8) GENIBUSmodule MPC
*9) CIM interfaces
*10) CIU interfaces
*11) incl. differential pressure sensor
*12) 4-20 mA Sensor required x available

9. TEMPERATURE CONTROL INDUSTRY

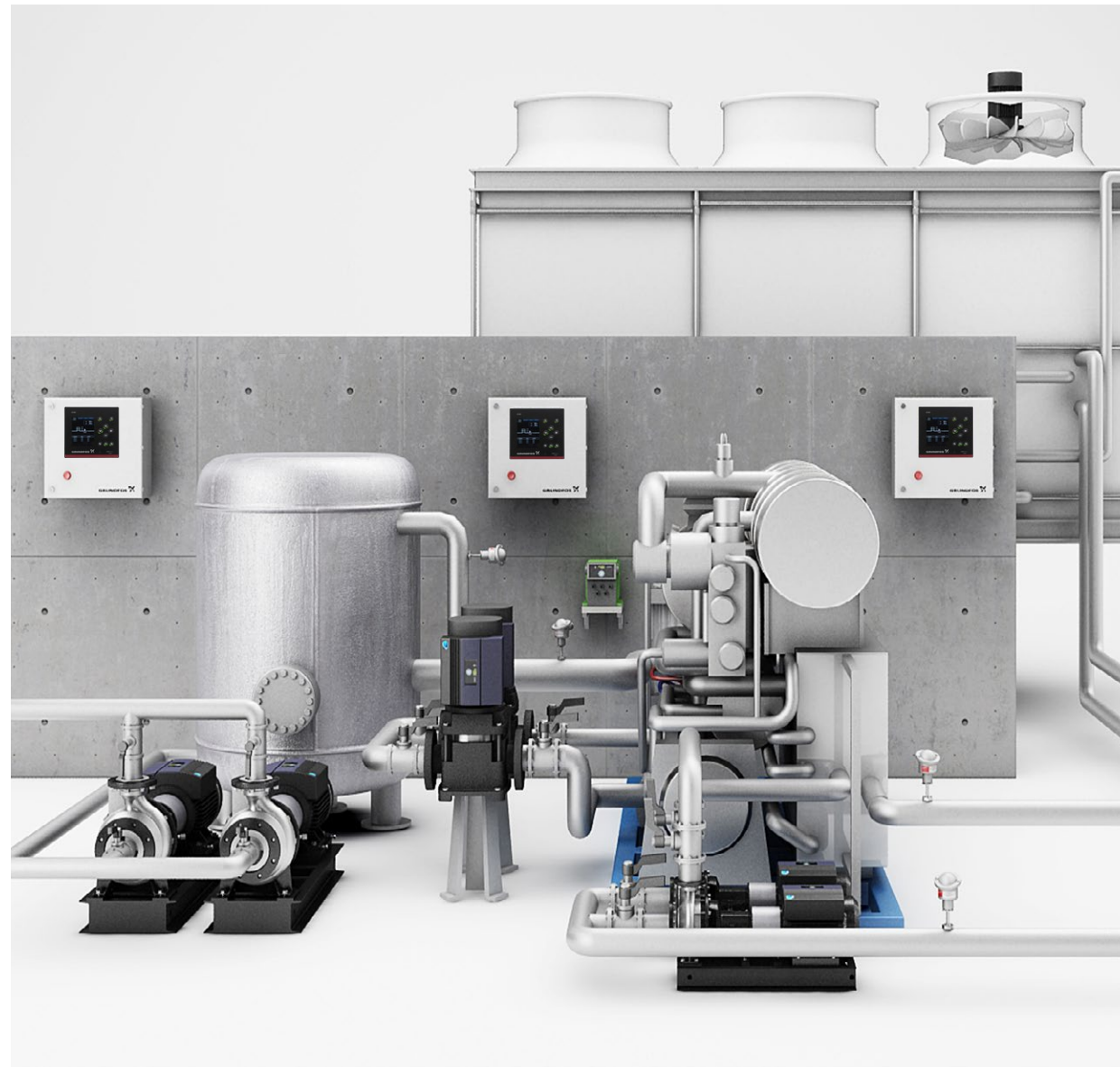

Based on decades of experience, Grundfos' E-solutions offer professional control that will add even more value to your system. Specifically in applications where reliable temperature control is essential, an E-solution will guarantee that the temperature never deviates the slightest from what is necessary to ensure optimum operating conditions. E-pumps with integrated frequency converter offer a superb array of pump-related functionality that will benefit most

systems in terms of comfort, user-friendliness, process adaptability and not least operating economy. By regulating pump speed according to demand energy consumption and operating costs are significantly reduced. Compared to conventional fixed-speed pump solutions E-solutions enable annual energy savings up to 50%.

9.1 PROCESS COOLING OR HEATING

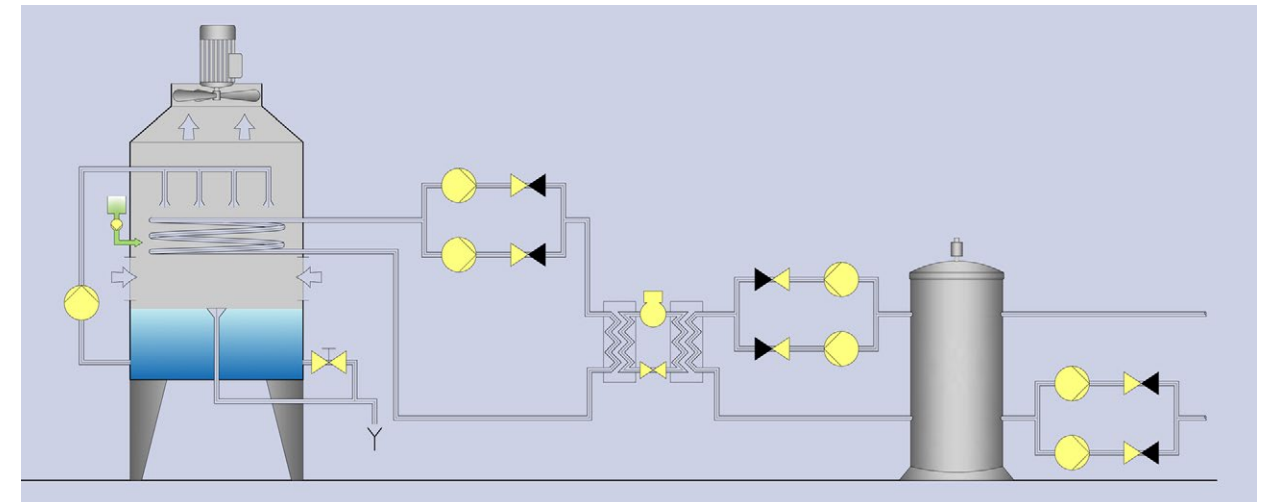

Additional benefits of E-solutions are:

- > Constant temperature – temperature is kept constant irrespective of the flow.
- > Automated derating – ensures optimum tolerance of ambient temperatures.
- > Set point influence – ensures reliable and precise response to parameter regulations.
- > Stand still heating – heats up the motor during stand still to avoid damaging condensation.
- > Communication with most SCADA systems

> Fewer components – pump, motor and converter are built into one to make installation, maintenance and service much easier.

Naturally, Grundfos E-solutions can be customised to meet specific requirements. Pump curves can be stretched, extra functions can be added and special operating panels can be included to mention but a few of the options. So if standard optimisation just isn't enough, please contact us for dedicated solutions.

Recommended product types: Pressure control, flow control	Control (depend on connected sensor)	Features													Pumps										
		single pump duty / standby	parallel cascade operation	Non e-pump	Relay outputs	Grundfos GO communication	R100 Infrared communication	BACnet data communication	LONWorks data communication	PROFIBUS DP/ PROFINET data communication	Modbus RTU data communication	EtherNet/IP data communication	Modbus TCP data communication	3G/4G cellular data communication	GiC/ GRM (Grundfos Remote Management)	GENibus data communication	Ethernet (VNC Server) data communication	No external sensor required	Sensor (0/4-20mA / 0-10V)	Analogue setpoint influence (0-10 V)	Grafic display with user interface	Start-up wizard	Motor protection	CR	CM
E-pump CRE, CME	P	x	x	*3)	*4)	x	x	*5)	*5)	*5)	*5)	*5)	*5)	*5)	*5)	x	x	x	x	x	x	x	x		
E-pump CRE (MGE model H/I/J)	P	x	x	x*3)	2	x	x	*5)	*5)	*5)	*5)	*5)	*5)	*5)	*5)			x	x	x	x	x	x		
Control MPC (CU352)	$\Delta p, PP, S, F, Dt, T, P$		x	x	2			*9)	*9)	*9)	*9)	*9)	*9)	*9)	*9)	x		x	x	x	x	x	x	x	x
CUE (Frequency converter)	$\Delta p, PP, S, F, Dt, T, P, L$	x	x	*3)	x	2		*10)	*10)	*10)	*10)	*10)	*10)	*10)	*10)	x		x	x	x	x	x	x	x	x
Control MP204 + IO112	$\Delta p, F, Dt, T, P$				x	1			*10)	*10)	*10)	*10)	*10)	*10)	x							x	x	x	x
MP204 (Motorprotection)		x			x	1	x	x		*10)	*10)	*10)	*10)	*10)	x							x	x	x	x

A= Autoadapt, Dp= Differential Pressure, P= Const. Pressure, PP= Proportional Pressure, T= Const. Temperature, DT= Differential Temperature, F= Const Flow, S= Const. Speed/Frequency, L=Level, pH=pH-Wert, Cl2= Chlorine, ClO2=Chlorine dioxide, O3=Ozone, PAA=Peracetic acid, H2O2=Hydrogen peroxide, FA=FlowAdapt

*1) E-pumps (MGE model H) + MAGNA3 cascade up to 2 pumps without ext. controller
 *2) TPED
 *3) E-pumps MGE model H/I/J cascade up to 2 pumps, with external Control MPC cascade up to 6 pumps possible. Note: data point "heat energy" only on twinpump available.

*4) MGE 3kW 2p/ 2.2kW 4.p -7.5 kW: 1 relay, 11-22kW: 2 relays
 *5) MGE model H/I/J: CIM interfaces, TPED and MGE model F/G: CIU interfaces
 *6) version CIM xx2 needed
 *7) DDA Option E-Box Profibus

*8) GENibusmodule MPC
 *9) CIM interfaces
 *10) CIU interfaces
 *11) incl. differential pressure sensor
 *12) 4-20 mA Sensor required x available

10. BOILER FEED - DUTY/STANDBY LEVEL CONTROL /SPEED CONTROL

INDUSTRY

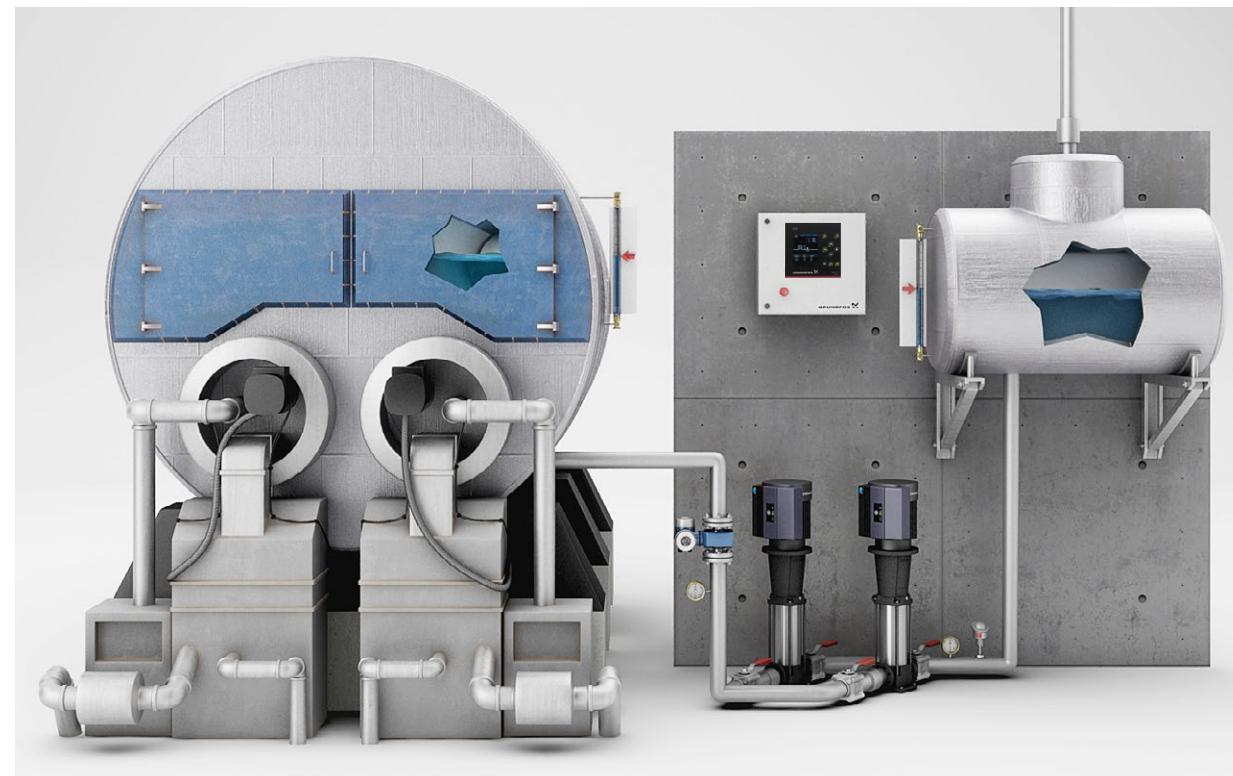

Hot water boiler:

Grundfos' single-stage and multistage pumps for hot water boilers are available for temperatures up to 140°C. All pumps can be controlled by a frequency converter which is either integrated in the motor or in a standard wall-mounted version, ensuring that the pressure and temperature in the system are constant. If the boiler requires a shunt in order to avoid thermal stress, we offer highly reliable pump solutions that will keep the temperature difference over the boiler constant.

Steam boiler:

Grundfos' unique feeding pumps for steam boilers offer unsurpassed efficiency. CR multistage pumps are capable of feeding boilers between 0.5 and 180 m³ water at 180°C per hour, and the volume is easily increased by applying more pumps.

Designed to withstand the high pressure, the high media and ambient temperatures and the significant number of starts and stops encountered in boiler applications, the pumps have been optimised in every aspect – and are even capable of efficiently handling poor inlet conditions. The pumps can further be supplied with an air-cooled top that protects the shaft seal from any damage caused by high temperatures.

Thermal oil:

Thermal oil is a highly suitable – and safe – alternative to steam in many processes, particularly where the dangers of high pressure are to be avoided. Grundfos' range of feeding pumps for thermal oil applications handles temperatures up to 240°C.

10.1 BOILER FEED

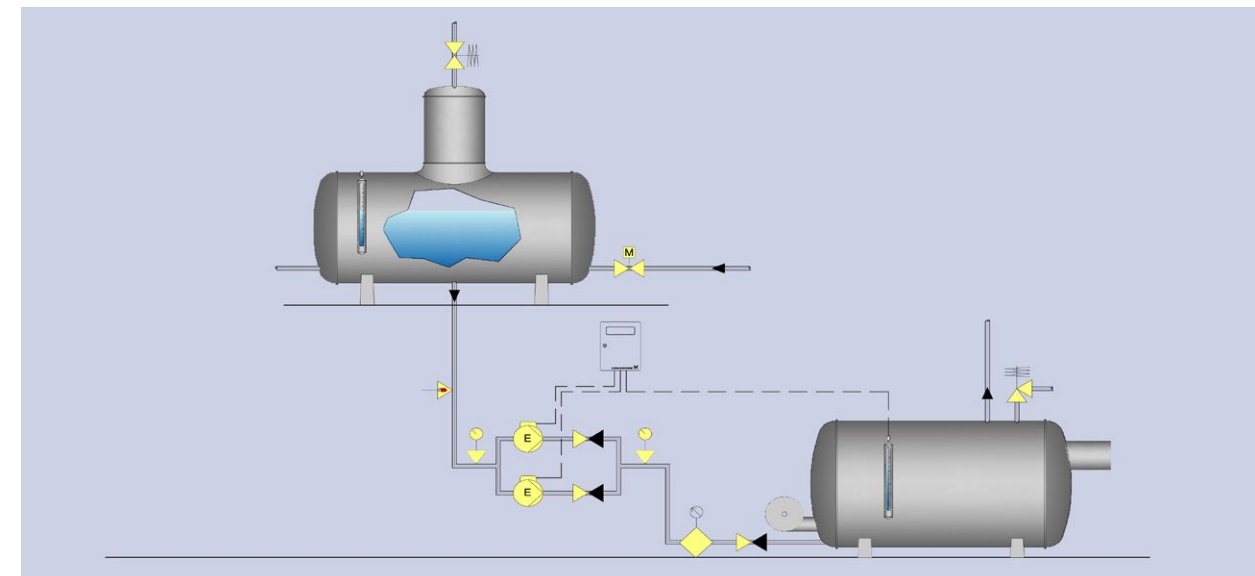

Boiler feed

Note: Boiler feed application is described in details in the Grundfos Engineering manual including this topic.

Hot water boiler:

- Constant pressure and constant temperature control on shunt pump.

Steam boiler:

- Constant level control, against high system pressure.
- Cavitation prevention, by controlling the duty point.
- Curve compensation of unstable pump characteristics
- Duty stand by function.

Thermal oil boiler:

- Constant pressure and constant temperature control on shunt pump.

Boiler feed		Features														Pumps										
Recommended product types: Pressure control, flow control	Control (depend on connected sensor)	single pump	duty / standby	parallel cascade operation	Non e-pump	Relay outputs	Grundfos GO communication	R100 Infrared communication	BACnet data communication	LONworks data communication	PROFIBUS DP/ PROFINET data communication	Modbus RTU data communication	EtherNet/IP data communication	Modbus TCP data communication	3G/4G cellular data communication	GIC/GRM (Grundfos Remote Management)	GENibus data communication	Ethernet (VNC Server) data communication	No external sensor required	Sensor (0)4-20mA / 0-10V	Analogue setpoint influence (0-10 V)	Graphic display with user interface	Start-up wizard	Motor protection	CR	CM
		E-pump CRE, CME	P	x	x	*3)		*4)	x	x	*5)	*5)	*5)	*5)	*5)	*5)	*5)	*5)	*5)			x	x			
E-pump CRE (MGE model H/I/J)	P	x	x	x*3)		2	x	x	*5)	*5)	*5)	*5)	*5)	*5)	*5)	*5)	*5)					x	x	x	x	
Control MPC (CU352)	Δp,PP,S,F,Dt,T,P			x	x	2			*9)	*9)	*9)	*9)	*9)	*9)	*9)	*9)	*9)	x				x	x	x	x	x
CUE (Frequency converter)	Δp,PP,S,F,Dt,T,P,L	x	x	*3)	x	2			*10)	*10)	*10)	*10)	*10)	*10)	*10)	*10)	*10)	x				x	x	x	x	x
Control MP204 + IO112	Δp,F,Dt,T,P				x	1				*10)	*10)	*10)	*10)	*10)	*10)	*10)	*10)	x		*12)			x	x	x	
MP204 (Motorprotection)		x				x	1	x			*10)	*10)	*10)	*10)	*10)	*10)	x						x	x	x	

A= Autoadapt, Dp= Differential Pressure, P= Const. Pressure, PP= Proportional Pressure, T= Const. Temperature, DT= Differential Temperature, F= Const Flow, S= Const. Speed/Frequency, L=Level, pH=pH-Wert, Cl2= Chlorine, ClO2=Chlorine dioxide, O3=Ozone, PAA=Peracetic acid, H2O2=Hydrogen peroxide, FA=FlowAdapt

*1) E-pumps (MGE model H) + MAGNA3 cascade up to 2 pumps without ext. controller
*2) TPED
*3) E-pumps MGE model H/I/J cascade up to 2 pumps, with external Control MPC cascade up to 6 pumps possible. Note: data point "heat energy" only on twinpump available.

*4) MGE 3kW 2p./ 2,2kW 4.p -7.5 kW: 1 relay, 11-22kW: 2 relays
*5) MGE model H/I/J: CIM interfaces, TPED and MGE model F/G: CIU interfaces
*6) version CIM xx2 needed
*7) DDA Option E-Box Profibus

*8) GENibusmodule MPC
*9) CIM interfaces
*10) CIU interfaces
*11) incl. differential pressure sensor
*12) 4-20 mA Sensor required x available

12. WASH 'N' CLEAN

INDUSTRY

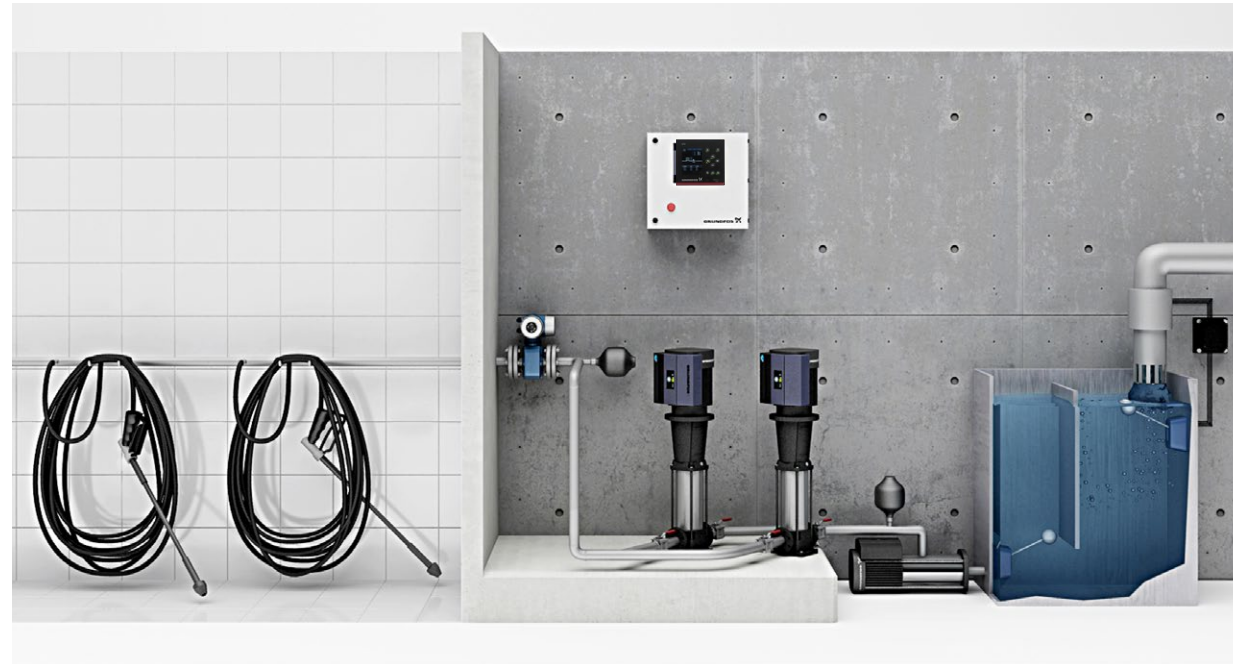

Grundfos has many years of experience in the wash and cleaning business. We offer a variety of dedicated solutions for e.g.:

- Vehicle washes
- Wash-down systems
- Part washers
- CIP/SIP.

The thoroughly tested range is built on more than 60 years of experience and includes very compact pumps that will save you space without compromising performance. In addition to the pumps themselves, Grundfos offers you an array of motors, speed controls and monitors that will improve the performance of the system.

If you are building a new washing and cleaning system, we recommend that you talk to us as early in the development process as possible. By far the majority of our pumps can be easily adjusted to match your specific requirements and optimise the entire system.

Grundfos' pumps are highly suitable for part washer applications in the industry, allowing the pumps to be customised in terms of flow and pressure to accommodate individual requirements.

The single-stage or multistage centrifugal pumps operate in temperatures up to 180°C and at pressures up to 50 bar in a large variety of applications.

On top of the range of standard pumps available for washers, Grundfos also offers special pumps developed to handle different media. If the water contains oil, the shaft seal material must be able to withstand this specific liquid – while particularly aggressive detergents require that also the pump material has been designed for this challenge. Naturally, all pumps for part washers can be supplied with dosing pumps that accurately dose the detergent and solvents.

CIP (Cleaning In Place) and SIP (Sterilisation In Place) systems are ideal in industries where hygiene is of the utmost importance and contamination must be avoided at all costs. Without dismantling any equipment, tanks, pipes and entire process lines can be efficiently cleaned, saving time and in turn money. Grundfos' CIP pumps, handling temperatures all the way up to 180 °C, are made of stainless steel to be able to withstand the aggressive detergents encountered in cleaning processes. As the CIP system is never in contact with the actual process – be it food or pharmaceuticals – sanitary pumps are not required. CIP pumps are, however, usually electro-polished to make sure that no residues stick to the inside. Precise dosing pumps can further speed up the CIP process by adding only the necessary detergent, consequently reducing the flushing of the system. As for the slightly more demanding SIP process, Grundfos multistage pumps are used to feed the boiler producing the steam that efficiently cleans e.g. bottles at very high temperatures.

12.1 WASH 'N' CLEAN

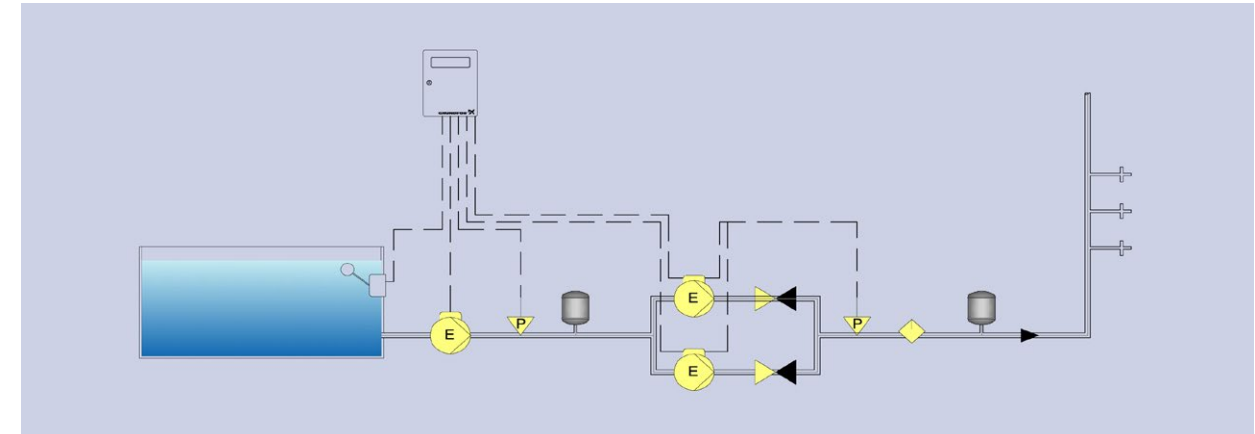

Wash and cleaning operate with a variety of control principles. The idea is to have the pump running and generating pressure when the washing is going on. For systems with feeding pressure, they typically start on flow signal from either flow switch or flow-meter. They stop on either pressure or flow signal, and operate without tank or accumulation.

For systems with break tank, they need a small tank to keep pressure. Stop signal comes from either flow or pressure signal. Start will typically be on pressure, but can be combined with flow signal.

Signal can here mean both analog signal and switch. The instrumentation can be used for monitoring and control.

Wash n' clean		Features														Pumps																		
Recommended product types: Pressure control, flow control	Control (depend on connected sensor)	single pump	parallel cascade operation	Relay outputs	Non e-pump	Grundfos GO communication	R100 Infrared communication	BACnet data communication	LONWorks data communication	PROFIBUS DP/ PROFINET data communication	Modbus RTU data communication	EtherNet/IP data communication	Modbus TCP data communication	3C/4G cellular data communication	Gic/ GRM (Grundfos Remote Management)	GENIBUS data communication	Ethernet (VNC Server) data communication	No external sensor required	Sensor (0/4-20mA / 0-10V)	Analogue setpoint influence (0-10 V)	Grafic display with user interface	Start-up wizard	Motor protection	CR	CM	SMART-Digital S (DDE-P, DDC, DDA)	Smart Digital XL (DDE-AR, DDA)	DME-AR	DMX/DMH-AR	DNX/DMH-AT				
		E-pump CRE, CME	S,F,Dt,T,P	x	x	*3)	*4)	x	x	*5)	*5)	*5)	*5)	*5)	*5)	*5)	*5)			x	x													
E-pump CRE (MGE model H/I/J)	S,F,Dt,T,P	x	x	x*3)	2	x	x	*5)	*5)	*5)	*5)	*5)	*5)	*5)	*5)			x	x	x	x	x	x											
Control MPC (CU352)	Δp,PP,S,F,Dt,T,P		x	x	2			*9)	*9)	*9)	*9)	*9)	*9)	*9)	*9)			x	x	x	x	x	x	x	x									
CUE (Frequency converter)	Δp,PP,S,F,Dt,T,P,L	x	x	*3)	x	2		*10)	*10)	*10)	*10)	*10)	*10)	*10)	*10)	x			x	x	x	x	x	x	x									
MP204 (Motorprotection)		x			x	1	x	x		*10)	*10)		*10)	*10)	*10)	x							x	x	x									
DID	pFCI, TCI, ClO2, H2O2, PAA, ORP, pH, Cond.,T	x			2						x								x		x													x

A= Autoadapt, Dp= Differential Pressure, P= Const. Pressure, PP= Propotional Pressure, T= Const. Temperature, Dt= Differential Temperature, F= Const Flow, S= Const. Speed/Frequency, L=Level, pH=pH-Wert, Cl2= Chlorine, ClO2=Chlorine dioxide, O3=Ozone, PAA=Peracetic acid, H2O2=Hydrogen peroxide, FA=FlowAdapt

- *1) E-pumps (MGE model H) + MAGNA3 cascade up to 2 pumps without ext. controller
- *2) TPED
- *3) E-pumps MGE model H/I/J cascade up to 2 pumps, with external Control MPC cascade up to 6 pumps possible. Note: data point "heat energy" only on twinpump available.
- *4) MGE 3kW 2p./ 2,2kW 4.p -7,5 kW: 1 relay, 11-22kW: 2 relays
- *5) MGE model H/I/J: CIM interfaces, TPED and MGE model F/G: CIU interfaces
- *6) version CIM xx2 needed
- *7) DDA:E-Box, DDA XL: CIU
- *8) GENIBUSmodule MPC
- *9) CIM interfaces
- *10) CIU interfaces
- *11) incl. differential pressure sensor
- *12) 4-20 mA Sensor required x available

13. FILTER APPLICATION

INDUSTRY

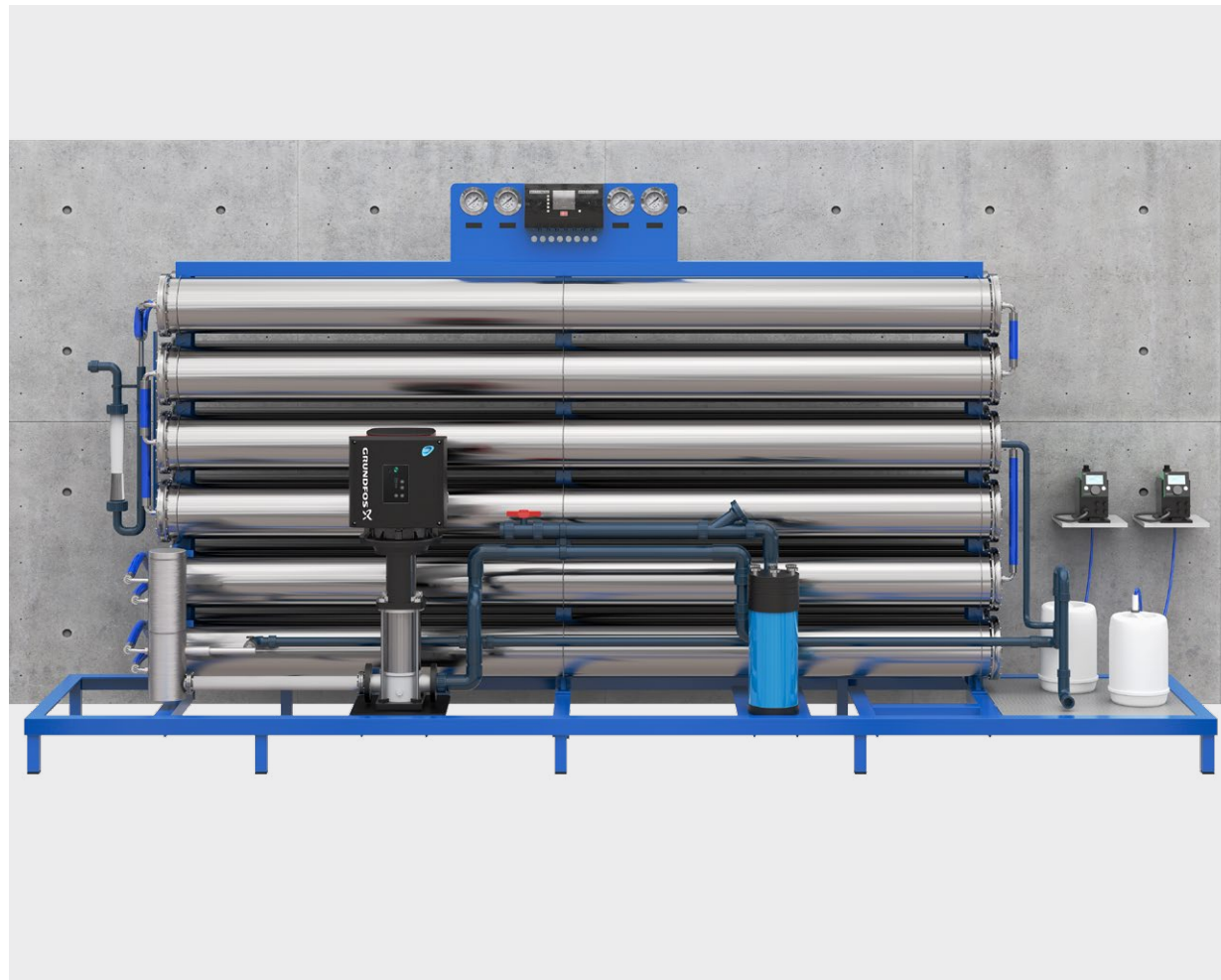

Reliable filtration is crucial in many industrial applications, prolonging the life of the products, pumped media, machines etc. Grundfos offers dedicated pumps for any filtration application.

Our range includes single-stage and multistage pumps, offering a very high flow essential to some filtration processes. Specifically for applications with particles in the media conveying into the filtration system, pumps with open impellers – and yet high efficiency – are available.

The pumps are ideal for both single filtration systems and central filtration systems and can be optionally supplied with E-solutions to optimise processes and increase reliability even further. Single filtration systems include for example:

- Paper belt filter

- Edge filter
- Vacuum filter
- Hydrostatic filter
- Drum filter
- Centrifugal filter
- Conveyors
- etc.

13.1 FILTER APPLICATION

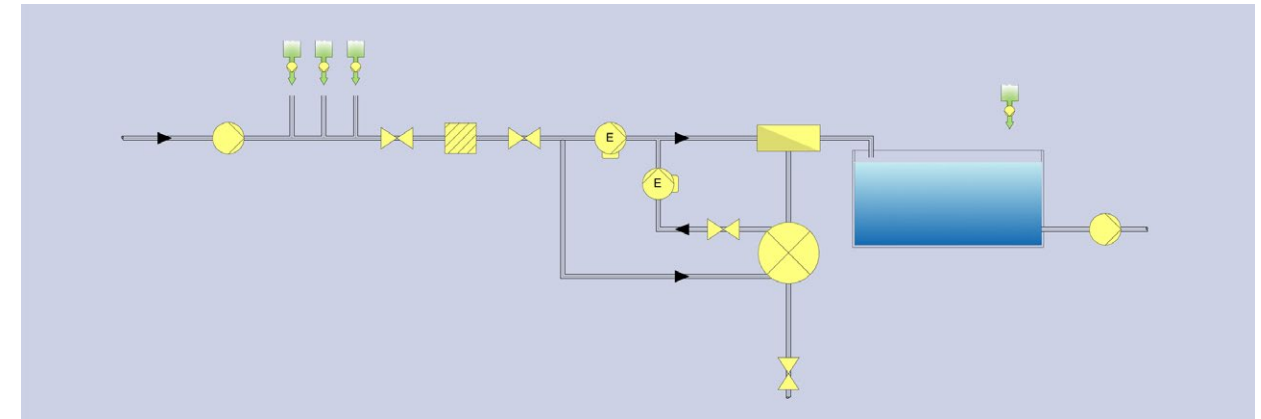

For operating the pumps we can use a variety of control systems. Some of the control ways normally used in filter applications are as follows.

- Constant pressure.
- Constant differential pressure across a filter unit.
- Constant flow through filters.
- Change in duty point for backflushing.
- etc.

Monitoring functions for filter units.

- Clogging
- Filter burst

Filter application	Recommended product types: Pressure control, flow control	Control (depend on connected sensor)	Features												Pumps											
			single pump duty / standby	parallel cascade operation	Non e-pump	Relay outputs	Grundfos CO communication	R100 Infrared communication	BACnet data communication	LONWorks data communication	PROFIBUS DP/ PROFINET data communication	Modbus RTU data communication	EtherNet/IP data communication	Modbus TCP data communication	3G/4G cellular data communication	GIC/ GRM (Grundfos Remote Management)	GENIbus data communication	Ethernet (VNC Server) data communication	No external sensor required	Sensor (0)4-20mA / 0-10V	Analogue setpoint influence (0-10 V)	Grafic display with user interface	Start-up wizard	Motor protection	CR, CM	NB;NK, TP; HS
E-pump CRE	S,F,Dt,T,P	x x *3)	x	x	*4)	x	x	*5)	*5)	*5)	*5)	*5)	*5)	*5)	*5)			x	x			x				
E-pump NBE	S,F,Dt,T,P	x		*3)	*4)	x	x	*5)	*5)	*5)	*5)	*5)	*5)	*5)					x	x			x			
E-pump NKE	S,F,Dt,T,P	x		*3)	*4)	x	x	*5)	*5)	*5)	*5)	*5)	*5)						x	x			x			
E-pump CRE (MGE model H/I/J)	S,F,Dt,T,P	x x x,*3)	x	x	x	x	x	x	x	x	x	x	x	x	x	x	x	x	x	x	x	x	x	x	x	x
Control MPC (CU352)	Δp,PP,S,F,Dt,T,P		x	x	x	2			*9)	*9)	*9)	*9)	*9)	*9)	*9)	*9)	x		x	x	x	x	x	x	x	x
CUE (Frequency converter)	Δp,PP,S,F,Dt,T,PL	x x *3)	x	x	2				*10)	*10)	*10)	*10)	*10)	*10)	*10)	x			x	x	x	x	x	x	x	x
MP204 (Motorprotection)		x			x	1	x	x				*10)	*10)			x			x			x	x	x	x	x
Smart Digital S (DDE-P(R), DDC, DDA), Smart Digital XL (DDE-AR, DDA), DME-AR, DMX/DMH-AR, DMX/DMH-AT"												*7)	*7)			DDA										

A= Autoadapt, Dp= Differential Pressure, P= Const. Pressure, PP= Propotional Pressure, T= Const. Temperature, Dt= Differential Temperature, F= Const Flow, S= Const. Speed/Frequency, L=Level, pH=pH-Wert, Cl2= Chlorine, ClO2=Chlorine dioxide, O3=Ozone, PAA=Peracetic acid, H2O2=Hydrogen peroxide, FA=FlowAdapt

*1) E-pumps (MGE model H) + MAGNA3 cascade up to 2 pumps without ext. controller
 *2) TPED
 *3) E-pumps MGE model H/I/J cascade up to 2 pumps, with external Control MPC cascade up to 6 pumps possible. Note: data point "heat energy" only on twinpump available.
 *4) MGE 3kW 2p./ 2,2kW 4.p -7,5 kW: 1 relay, 11-22kW: 2 relays
 *5) MGE model H/I/J: CIM interfaces, TPED and MGE model F/G: CIU interfaces
 *6) version CIM xx2 needed
 *7) DDA:E-Box, DDA XL: CIU
 *8) GENIbusmodule MPC
 *9) CIM interfaces
 *10) CIU interfaces
 *11) incl. differential pressure sensor
 *12) 4-20 mA Sensor required x available

15.2 SURFACE WATER

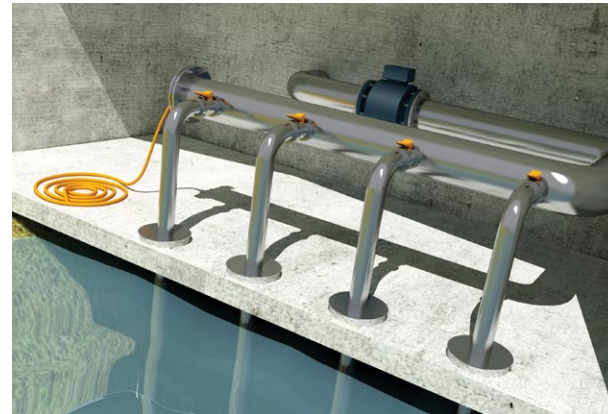

Surface water intake relates to pump systems that draw water from lakes, rivers or spring wells. The installation power can go up to several hundred Kilowatts in order to feed large water treatment plants or irrigation systems. Different site conditions and varying seasonal water qualities require tailored solutions for the pump unit and customized control solutions. Drawing surface water from a shallow well at a lake shore or river bank provides easily treatable water that has been naturally filtered. Grundfos submersible multistage SP are ideal for such installations. The logical consequence for higher capacities is a switchover to vertical turbine pumps, vertical column

pipe installations and all types of large single stage centrifugal pumps such as the Grundfos Splitcase range. A direct water extraction from lakes and rivers always needs proper screening at the intake in combination with a settling basin (optional) and a suitable pump that allows for remaining particles.

The fully automated disinfection systems developed by Grundfos offer an easy solution for chlorine-based disinfection methods. Grundfos can advise and supply disinfection solutions using chlorine compounds such as chlorine gas (Cl₂), sodium hypochlorite (NaOCl), and chlorine dioxide (ClO₂).

By integrating variable speed drives and motor protection, controls and communication systems, Grundfos can offer complete systems that are pre-engineered to work together. Grundfos CUE frequency converters represent one of the most comprehensive and versatile ranges of external variable speed drives for pump applications currently on the market. Together with the easy to use MP204 (for SP) or Control MPC motor protection, we provide robust control systems and ensure 24-hour monitoring and control of all vital parameters, such as dry-running or overload, to ensure operational stability.

Adding the benefits of remote management could mean savings of up to 20% on power consumption, chemicals and testing at final treatment. Together with stand of the art communication systems, the Grundfos products can be easily embedded into SCADA and automation systems.

15.3 SEA WATER



Factories and power generating plants are using large amounts of seawater for their cooling systems. Moreover, fish farms are increasingly raise fish in land-based ponds by pumping in seawater. In addition, desalination of seawater is rapidly becoming an additional and necessary source of potable water in many parts of the world, and Grundfos is a market leader supplying total pumping solutions for desalination.

Grundfos can equip reverse osmosis plants operating in a one-stage or two-stage systems utilising pumps constructed in stainless steel with high corrosion classes and energy recovery

systems with pump turbines at discharge. Such a construction can result in cost savings on maintenance, repair, power consumption and chemicals at the desalination plant. Seawater is best treated at source to ensure the easiest discharge and minimise the extent of corrosion risk. Depending on the flow requirements and the salt content, a seawater intake may be hundreds of meters out to sea, while an on-shore seawater intake could be corrosion-safe beach wells or coastal bank filtration.

Grundfos can supply pumps for both dry and submerged installation. In particular, Grundfos SPRE pumps are specifically designed to withstand corrosion, especially where the water has a high concentration of hydrocarbons and many chemicals.

The fully automated disinfection systems developed by Grundfos offer an easy solution for chlorine-based disinfection methods. Grundfos can advise and supply disinfection solutions using chlorine compounds such as chlorine gas (Cl₂), sodium hypochlorite (NaOCl), and chlorine dioxide (ClO₂). The automated processes require very little maintenance, provide very high efficiency, and reduce running costs.

By integrating variable speed drives and motor protection components, Grundfos can offer complete systems that are pre-engineered to work together. Grundfos CUE frequency converters represent one of the most comprehensive and versatile ranges of external variable speed drives for pump applications currently on the market. Together with the easy to use MP 204 motor protection, we ensure 24-hour monitoring and control of all vital parameters, such as dry-running or overload, to ensure operational stability.

Surface water		Features														Pumps															
Recommended product types: Dosing, level control, pressure control, flow control	Control (depend on connected sensor)	single pump	parallel cascade operation	Non e-pump	Relay outputs	Grundfos GO communication	R100 Infrared communication	BACnet data communication	LonWorks data communication	PROFIBUS DP/ PROFINET data communication	Modbus RTU data communication	EtherNet/IP data communication	Modbus TCP data communication	3C/4G cellular data communication	GIC/ GRM data communication (Grundfos Remote Management)	GENibus data communication	Ethernet (VNC Server) data communication	No external sensor required	Sensor (0/4-20mA / 0-10V)	Energy optimizing functions	Graphic display with user interface	Start-up wizard	Motor protection	SP	NK, TP, CR	LS, HS, RP, S	Peerless pumps + YCC pumps	KPL, KWM	**SMART-Digital (DDE-P, DDC, DDA) DDA Smart XL, DME-AR, DMX/DMH-AT**		
		Control MPC (CU352)	Δp, PP, S, F, Dt, T, P	x	x	x	2					*9	*9	*9	*9	*9	*9	*9	x	x	x	x	x	x	x	x	x	x	x	x	x
CUE (Frequency converter)	Δp, PP, S, F, Dt, T, P, L	x	x	*3	x	2				*10	*10	*10	*10	*10	*10	*10	x	x	x	x	x	x	x	x	x	x	x	x	x	x	
MP 204 (Motor protection)		x			1	x				*10	*10	*10	*10	*10	*10	x															
Conex DIA-1	pH, Redox, Cl ₂ , ClO ₂ , O ₃ , PAA, H ₂ O ₂	x								DDA *7)	DDA *7)					DDA															x
Conex DIA-2	pH, Redox, Cl ₂ , ClO ₂ , O ₃ , H ₂ O ₂	x																													x
Conex DIA-2Q	pH, Redox, Cl ₂ , ClO ₂ , O ₃ , PAA, H ₂ O ₂	x																													x
DIP	pH, Redox, Cl ₂	x																													x
Conex DIS-D	Cl ₂ , ClO ₂ , O ₃	x																													x
Conex DIS-PR	pH, Redox	x																													x
Conex DIS-C	conductivity inductive/ conductive	x																													
"SMART-Digital (DDE-P, DDC, DDA) DDA Smart XL, DME-AR, DMX/DMH-AT"										*7)	*10	*10				DDA															

A= Autoadapt, Dp= Differential Pressure, P= Const. Pressure, PP= Proportional Pressure, T= Const. Temperature, DT= Differential Temperature, F= Const Flow, S= Const. Speed/Frequency, L=Level, pH=pH-Wert, Cl₂= Chlorine, ClO₂=Chlorine dioxide, O₃=Ozone, PAA=Peracetic acid, H₂O₂=Hydrogen peroxide

*3) E-pumps MGE model H/I/J cascade up to 2 pumps, with external Control MPC cascade up to 6 pumps possible. Note: data point "heat energy" only on twinpump available.

*6) version CIU xx2 needed
*7) DDA:E-Box, DDA XL: CIU
*8) GENibusmodule MPC
**9) CIM interfaces

10) CIU interfaces
*11) incl. differential pressure sensor
*12) 4-20 mA Sensor required
x available

Sea water		Features														Pumps															
Recommended product types: Dosing, level control, pressure control, flow control	Control (depend on connected sensor)	single pump	parallel cascade operation	Non e-pump	Relay outputs	Grundfos GO communication	R100 Infrared communication	BACnet data communication	LonWorks data communication	PROFIBUS DP/ PROFINET data communication	Modbus data communication	EtherNet/IP data communication	Modbus TCP data communication	3C/4G cellular data communication	GIC/ GRM data communication (Grundfos Remote Management)	GENibus data communication	Ethernet (VNC Server) data communication	No external sensor required	Sensor (0/4-20mA / 0-10V)	Energy optimizing functions	Graphic display with user interface	Start-up wizard	Motor protection	SP	NB, NK	CR	BM / BME (T)	HS, Peerless VTP, YCC, Morris and KII KSN	**SMART-Digital (DDE-P, DDC, DDA) DDA Smart XL, DME-AR, DMX/DMH-AR, DMX/DMH-AT**		
		Control MPC (CU352)	Δp, PP, S, F, Dt, T, P	x	x	x	2					*9	*9	*9	*9	*9	*9	*9	x	x	x	x	x	x	x	x	x	x	x	x	x
CUE (Frequency converter)	Δp, PP, S, F, Dt, T, P, L	x	x	*3	x	2				*10	*10	*10	*10	*10	*10	*10	x	x	x	x	x	x	x	x	x	x	x	x	x	x	
MP 204																															
DID	FCI, TCI, ClO ₂ , H ₂ O ₂ , PAA, ORP, pH, Cond, T	x			2																										x
Smart Digital 5 (DDE-P(R), DDC, DDA) Smart Digital XL (DDE-AR, DDA), DME-AR, DMX/DMH-AR, DMX/DMH-AT**										*7)	*10	*10				DDA															

A= Autoadapt, Dp= Differential Pressure, P= Const. Pressure, PP= Proportional Pressure, T= Const. Temperature, DT= Differential Temperature, F= Const Flow, S= Const. Speed/Frequency, L=Level, pH=pH-Wert, Cl₂= Chlorine, ClO₂=Chlorine dioxide, O₃=Ozone, PAA=Peracetic acid, H₂O₂=Hydrogen peroxide

*3) E-pumps MGE model H/I/J cascade up to 2 pumps, with external Control MPC cascade up to 6 pumps possible. Note: data point "heat energy" only on twinpump available.

*6) version CIU xx2 needed
*7) DDA:E-Box, DDA XL: CIU
*8) GENibusmodule MPC
**9) CIM interfaces

10) CIU interfaces
*11) incl. differential pressure sensor
*12) 4-20 mA Sensor required
x available

16. WATER TREATMENT

MUNICIPAL WATERWORKS

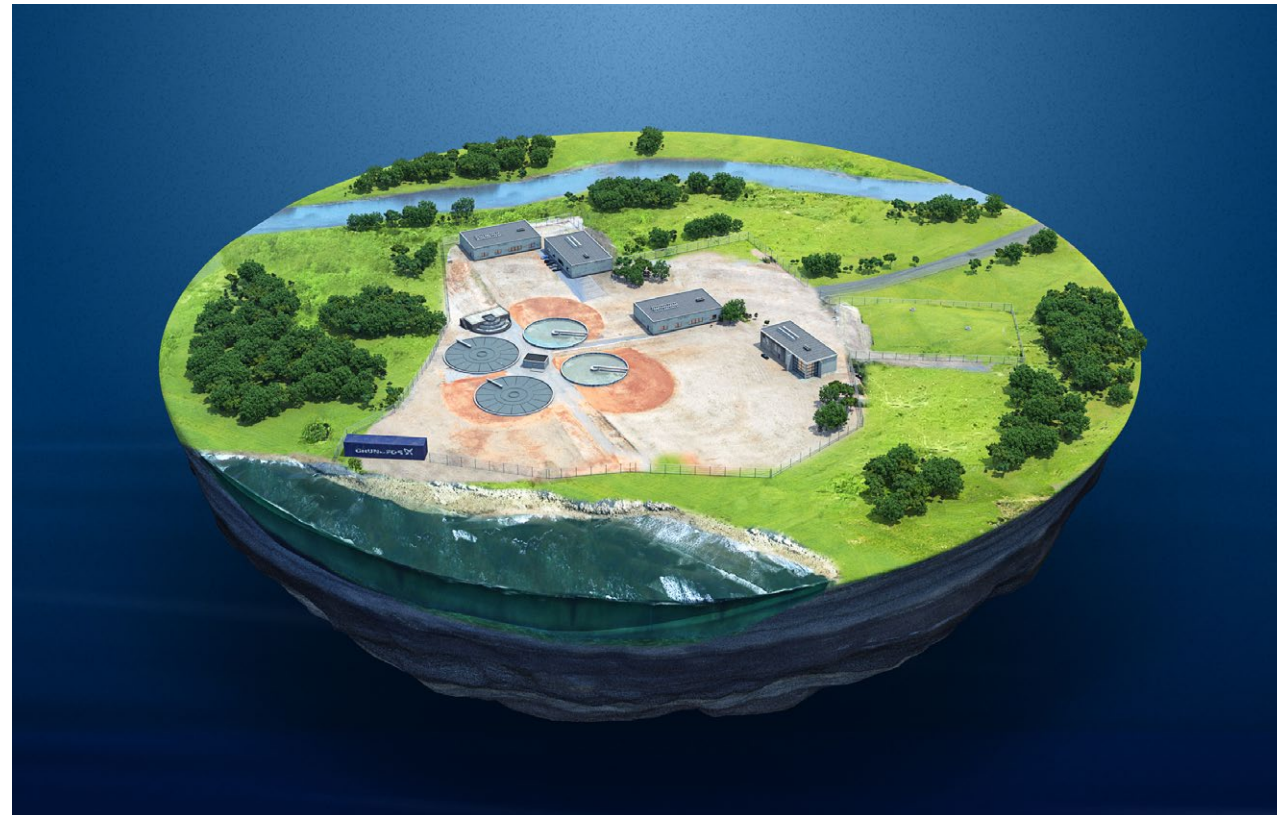

Even with a good water source, water treatment should be considered to ensure a good water quality. Water treatment describes those processes used to make water more acceptable for a desired end-use and to ensure that stringent quality standards to the consumer are maintained. Grundfos can supply pumping solutions for solids separation using mechanical treatments such as settling and filtration, dosing solutions for chemical treatments such as disinfection and coagulation.

For example, dissolved substances that are removed during drinking water treatment include calcium and magnesium from hard water, sulphur and carbon dioxide from acid water, iron from red water, manganese from brownish-black water, nitrate from fertiliser-contaminated water, hydrogen sulphide gas from rotten-egg smelling water, and sediments and organic matter from turbid water, where minerals may also be dissolved in high concentrations. Other desired end-uses for water could be for industrial processes or medical use.

Grundfos pump systems range from submersibles to end-suction pumps and huge split-case pumps as well as our highly successful vertical multistage centrifugal pump (CR).

Our complete range of dosing pump systems are for large or small volumes and based on different technologies; electronic and electrochemical accessories offer complete control; and PLC-controlled, fully automatic systems for dry material preparation and reliable dosing.

The sustainability of water treatment solutions requires that the pumping solution is durable, ensuring cost effective and trouble-free operation. Grundfos has decades of experience developing controller and monitoring systems for pumping solutions and manufactures its own pump motors for all fluid types and flow requirements.

External frequency converters (CUE) for variable speed drives and motor protection (MP204) to monitor motor conditions ensure optimal adaptation to changing conditions. This ensures a perfect match with hydraulics, motors, electrics, and all other mechanical components that make up a comprehensive pumping solution, ensuring the best possible efficiency point.

16.1. FILTRATION/ BACKWASH

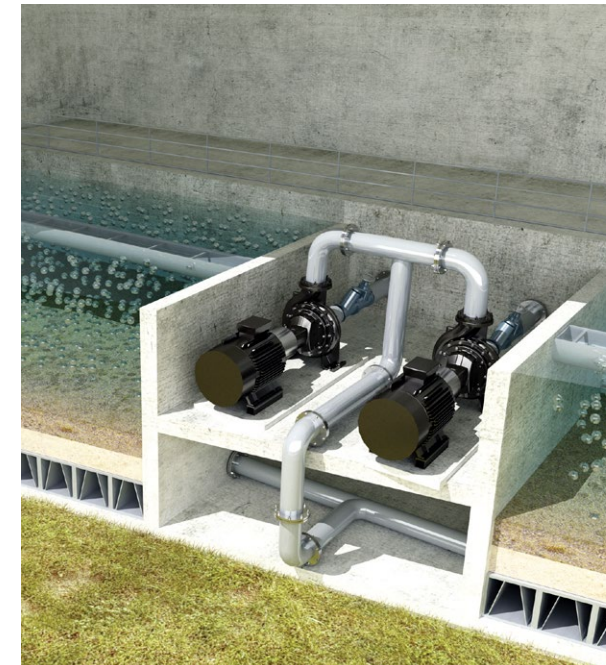

Final filtering of water for distribution is efficiently assisted by the Grundfos ranges of high-capacity pumps offering any pressure for any flow. Filtering processes range from a simple physical barrier to chemical or biological processes. Grundfos can supply pumping solutions to cope with the hugely varying flow requirements of water to be filtered or for backwashing, ranging from huge split-case and mixed-flow pumps, where the focus is on moving water rather than added pressure, to our highly successful vertical multistage centrifugal pump (CR) – and covering all performance requirements in between.

Backwashing refers to the reverse-pumping of water, for example for the periodic washing of filters. Grundfos can supply pumping solutions that deliver the very strong force with well-executed flush times and speeds required for effective backwashing. Backwashing is a form of preventive maintenance to prevent further clogging of the filter medium. Backwashing in water treatment plants is an automated process, usually run by programmable logic controllers (PLCs). The backwash cycle is usually triggered when the differential pressure over the filter exceeds a set value.

Filtration/ backwash		Features												Pumps															
Recommended product types: Dosing, level control, differential pressure control	Control (depend on connected sensor)	single pump	parallel cascade operation	Non e-pump	Relay outputs	Grundfos GO communication	R100 Infrared communication	BACnet data communication	LONWorks data communication	PROFIBUS DP/ PROFINET data communication	Modbus RTU data communication	EtherNet/IP data communication	Modbus TCP data communication	3G/4G cellular data communication	GiC/ GRM data communication	GENIBUS data communication	Ethernet (VNC Server) data communication	Night flow supervision / Remote pressure logging / wireless remote sensors	Sensor (0/4-20mA / 0-10V)	Energy optimizing functions	Graphic display with user interface	Start-up wizard	Motor protection	SP	NB, NK	CR	RM / BME (T)	HS	SMART-Digital (DDE-P, DDC, DDA) DDA Smart XL, DME-AR, DMX/DMH-AT*
		E-pump CRE	S,F,Dt,T,P	x	x	*3)	*4)	x	x	*5)	*5)	*5)	*5)	*5)	*5)	*5)	*5)			x	x				x				
E-pump NBE	S,F,Dt,T,P	x		*3)	*4)	x	x	*5)	*5)	*5)	*5)	*5)	*5)	*5)	*5)			x					x						
E-pump NKE	S,F,Dt,T,P	x		*3)	*4)	x	x	*5)	*5)	*5)	*5)	*5)	*5)	*5)	*5)			x											
E-pump CRE (MGE model H/I/J)	S,F,Dt,T,P	x	x	x,*3)	2	x	x	*5)	*5)	*5)	*5)	*5)	*5)	*5)	*5)			x	x	x	x	x	x	x	x				
Control MPC (CU352)	Δp,PP,S,F,Dt,T,P	x	x	x	2			*9)	*9)	*9)	*9)	*9)	*9)	*9)	*9)			x	x	x	x	x	x						
CUE (Frequency converter)	Δp,PP,S,F,Dt,T,PL	x	x	*3)	x	2		*10)	*10)	*10)	*10)	*10)	*10)	*10)	*10)			x	x	x	x	x	x	x	x				
MP 204 (Motor protection)		x			x	1	x			*10)	*10)		*10)	*10)									x	x	x	x			
Dosing & disinfection	pH, Redox, Cl2, ClO2, O3, PAA, H2O2	x																										x	
Smart Digital S (DDE-P(R), DDC, DDA) Smart Digital XL (DDE-AR, DDA), DME-AR, DMX/DMH-AR, DMX/DMH-AT*										*7)	*10)		*10)				DDA												

A= Autoadapt, Dp= Differential Pressure, P= Const. Pressure, PP= Proportional Pressure, T= Const. Temperature, DT= Differential Temperature, F= Const Flow, S= Const. Speed/Frequency, L=Level, pH=pH-Wert, Cl2= Chlorine, ClO2=Chlorine dioxide, O3=Ozone, PAA=Peracetic acid, H2O2=Hydrogen peroxide

*1) MAGNA3 cascade up to 2 pumps without ext. controller
 *2) TPED
 *3) E-pumps MGE model H/I/J cascade up to 2 pumps, with external Control MPC cascade up to 6 pumps possible. Note: data point "heat energy" only on twinpump available.

*4) All MGEs model H/I/J: 2 relays
 *5) MGE model H/I/J: CIM interfaces, TPED and MGE model F/G: CIU interfaces
 *6) version CIU xx2 needed
 *7) DDA:E-Box, DDA XL: CIU

*8) GENIBUSmodule MPC
 *9) CIM interfaces
 *10) CIU interfaces
 *11) incl. differential pressure sensor
 *12) 4-20 mA Sensor required x available

16.4 FLOCCULATION



Flocculation and sedimentation are widely employed in the purification of drinking water. Flocculants are used in water treatment processes to improve the sedimentation or filterability of small particles, for example to aid removal of microscopic particles that would otherwise cause the water to be turbid (cloudy) and which would be difficult or impossible to remove by filtration alone.

Correct flocculation requires reliable flow management from pumps systems and mixers and dosing pump systems – and Grundfos can supply all components. The Grundfos range of SE pumps are specifically designed for durable use and flow management, and can be installed dry or submerged. They offer the reliability you need to ensure correct sedimentation.

Grundfos can supply complete dosing pumps systems for large or small volumes and based on different technologies for flocculation, disinfection, and pH adjustment. Moreover, the Grundfos range of electronic and electrochemical accessories offers complete control of your dosing and disinfection processes and can be seamlessly integrated into your system.

Water quality improvement with an efficient, economical system for dry-material preparation is increasingly used for water treatment. Grundfos can supply PLC-controlled, fully automatic systems to handle preparation and the reliable dosing of organic coagulants or poly-electrolytes.

Changing load conditions require a pumps system that can handle large flows at low head. Grundfos AFG flowmakers offer an optimum, energy-efficient solution for mixing in big tanks, creating a bulk-flow with an almost uniform flow-velocity and limited risk of dead zones. Where tank design doesn't allow the use of flowmakers, Grundfos AMD and AMG mixers offer a robust design with corrosion resistant materials, easy service and maintenance, and trouble-free operation in difficult environments.

16.5 SEDIMENTATION

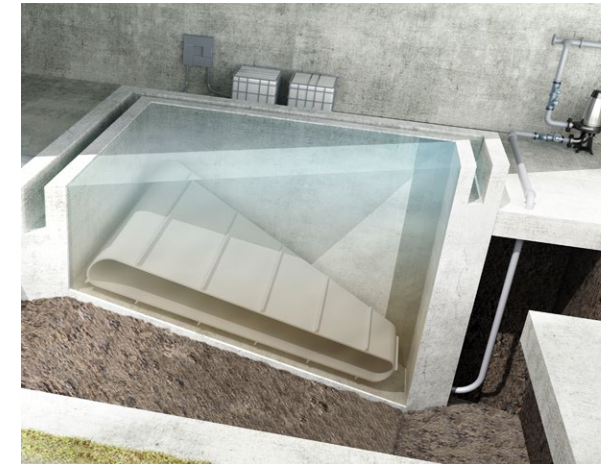

Sedimentation is a physical water treatment process used to settle out suspended solids in water under the influence of gravity. One of the requirements for correct sedimentation is maintaining gentle fluid handling with a pump system that is designed to avoid contact between the sediment and vital pump parts, reducing wear and tear.

Grundfos can supply pump systems that match these demands, and in addition has a range of disinfection solutions that lead to an increase in the settling speed of suspended material and help raise water quality.

Maintaining gentle and controlled flows in sedimentation tanks and moving water to and from the tanks places many demands on a pumping solution. Grundfos pump systems range from huge split-case and mixed-flow pumps, where the focus is on moving water rather than added pressure to our highly successful vertical multistage centrifugal pump (CR) – and covering all performance requirements in between.

Grundfos can supply complete dosing pump systems for large or small volumes and based on different technologies for flocculation, disinfection, and pH adjustment. Moreover, the Grundfos range of electronic and electrochemical accessories offers complete control of your dosing and disinfection processes and can be seamlessly integrated into your system.

Water quality improvement with an efficient, economical system for dry-material preparation is increasingly used for water treatment. Grundfos can supply PLC-controlled, fully automatic systems to handle preparation and the reliable dosing of organic coagulants or poly-electrolytes

Flocculation		Features																Pumps											
Recommended product types: Dosing, level control, pressure control, flow control	Control (depend on connected sensor)	single pump	parallel	Non e-pump	Relay outputs	Grundfos GO communication	R100 Infrared communication	BACnet data communication	LONWorks data communication	PROFIBUS DP/ PROFINET data communication	Modbus RTU data communication	EtherNet/IP data communication	Modbus TCP data communication	3G/4G cellular data communication	GIC/ GRM data communication (Grundfos Remote Management)	GENibus data communication	Ethernet (VNC Server) data communication	No external sensor required	Sensor (0)4-20mA / 0-10V	Energy optimizing functions	Graphic display with user interface	Start-up wizard	Motor protection	S-SE,SL	SRP Recirculation pumps	AMG, AMD,AFG Mixer	"SMART-Digital (DDE-P, DDC, DDA)	DDA Smart XL, DME-AR, DMX/DMH-AR, DMX/DMH-AT"	
		E-pump CRE	S,F,Dt,T,P	x	x	*3	*4	x	x	*5	*5	*5	*5	*5	*5	*5	*5	*5											
E-pump NBE	S,F,Dt,T,P	x		*3	*4	x	x	*5	*5	*5	*5	*5	*5	*5	*5	*5													
E-pump NKE	S,F,Dt,T,P	x		*3	*4	x	x	*5	*5	*5	*5	*5	*5	*5	*5	*5													
E-pump CRE (MGE model H/I/J)	S,F,Dt,T,P	x	x	*3	2	x	x	*5	*5	*5	*5	*5	*5	*5	*5	*5													
Control MPC (CU352)	Δp,PP,S,F,Dt,T,P	x	x	x	2			*9	*9	*9	*9	*9	*9	*9	*9	*9	x												
CUE (Frequency converter)	Δp,PP,S,F,Dt,T,P,L	x	x	*3	x	2		*10	*10	*10	*10	*10	*10	*10	*10	x													
MP 204 (Motor protection)		x			x	1	x	x		*10	*10																		
Dosing & disinfection	pH, Redox, Cl2, ClO2, O3, PAA, H2O2	x																											x
Smart Digital S (DDE-P(R), DDC, DDA) Smart Digital XL (DDE-AR, DDA), DME-AR, DMX/DMH-AR, DMX/DMH-AT"										*7	*10																		

A= Autoadapt, Dp= Differential Pressure, P= Const. Pressure, PP= Proportional Pressure, T= Const. Temperature, DT= Differential Temperature, F= Const Flow, S= Const. Speed/Frequency, L=Level, pH=pH-Wert, Cl2= Chlorine, ClO2=Chlorine dioxide, O3=Ozone, PAA=Peracetic acid, H2O2=Hydrogen peroxide

*1) MAGNA3 cascade up to 2 pumps without ext. controller
*2) TPED
*3) E-pumps MGE model H/I/J cascade up to 2 pumps, with external Control MPC cascade up to 6 pumps possible. Note: data point "heat energy" only on twinpump available.

*4) All MGEs model H/I/J: 2 relay
*5) MGE model H/I/J: CIM interfaces, TPED and MGE model F/G: CIU interfaces
*6) version CIU xx2 needed
*7) DDA:E-Box, DDA XL: CIU

*8) GENibusmodule MPC
*9) CIM interfaces
*10) CIU interfaces
*11) incl. differential pressure sensor
*12) 4-20 mA Sensor required
x available

Sedimentation		Features																Pumps											
Recommended product types: Dosing, level control, pressure control, flow control	Control (depend on connected sensor)	single pump	parallel	Non e-pump	Relay outputs	Grundfos GO communication	R100 Infrared communication	BACnet data communication	LONWorks data communication	PROFIBUS DP/ PROFINET data communication	Modbus RTU data communication	EtherNet/IP data communication	Modbus TCP data communication	3G/4G cellular data communication	GIC/ GRM data communication (Grundfos Remote Management)	GENibus data communication	Ethernet (VNC Server) data communication	No external sensor required	Sensor (0)4-20mA / 0-10V	Energy optimizing functions	Graphic display with user interface	Start-up wizard	Motor protection	NB;NK;TP;HS,CR	S-SE	AMG, AMD,AFG Mixer	"SMART-Digital (DDE-P, DDC, DDA)	DDA Smart XL, DME-AR, DMX/DMH-AR, DMX/DMH-AT"	
		E-pump CRE	S,F,Dt,T,P	x	x	*3	*4	x	x	*5	*5	*5	*5	*5	*5	*5	*5	*5											
E-pump NBE	S,F,Dt,T,P	x		*3	*4	x	x	*5	*5	*5	*5	*5	*5	*5	*5	*5													
E-pump NKE	S,F,Dt,T,P	x		*3	*4	x	x	*5	*5	*5	*5	*5	*5	*5	*5	*5													
E-pump CRE (MGE model H/I/J)	S,F,Dt,T,P	x	x	*3	2	x	x	*5	*5	*5	*5	*5	*5	*5	*5	*5													
Control MPC (CU352)	Δp,PP,S,F,Dt,T,P	x	x	x	2			*9	*9	*9	*9	*9	*9	*9	*9	*9	x												
CUE (Frequency converter)	Δp,PP,S,F,Dt,T,P,L	x	x	*3	x	2		*10	*10	*10	*10	*10	*10	*10	*10	*10	x												
MP 204 (Motor protection)		x			x	1	x	x		*10	*10																		
Dosing & disinfection	pH, Redox, Cl2, ClO2, O3, PAA, H2O2	x																											x
Smart Digital S (DDE-P(R), DDC, DDA) Smart Digital XL (DDE-AR, DDA), DME-AR, DMX/DMH-AR, DMX/DMH-AT"																													
Control DC (Dedicated Controls)	L	x	x	x	x	2				*9	*9			*9	*9	*9	x												

A= Autoadapt, Dp= Differential Pressure, P= Const. Pressure, PP= Proportional Pressure, T= Const. Temperature, DT= Differential Temperature, F= Const Flow, S= Const. Speed/Frequency, L=Level, pH=pH-Wert, Cl2= Chlorine, ClO2=Chlorine dioxide, O3=Ozone, PAA=Peracetic acid, H2O2=Hydrogen peroxide

*1) MAGNA3 cascade up to 2 pumps without ext. controller
*2) TPED
*3) E-pumps MGE model H/I/J cascade up to 2 pumps, with external Control MPC cascade up to 6 pumps possible. Note: data point "heat energy" only on twinpump available.

*4) All MGEs model H/I/J: 2 relay
*5) MGE model H/I/J: CIM interfaces, TPED and MGE model F/G: CIU interfaces
*6) version CIU xx2 needed
*7) DDA:E-Box, DDA XL: CIU

*8) GENibusmodule MPC
*9) CIM interfaces
*10) CIU interfaces
*11) incl. differential pressure sensor
*12) 4-20 mA Sensor required
x available

17. WATER DISTRIBUTION

MUNICIPAL WATERWORKS

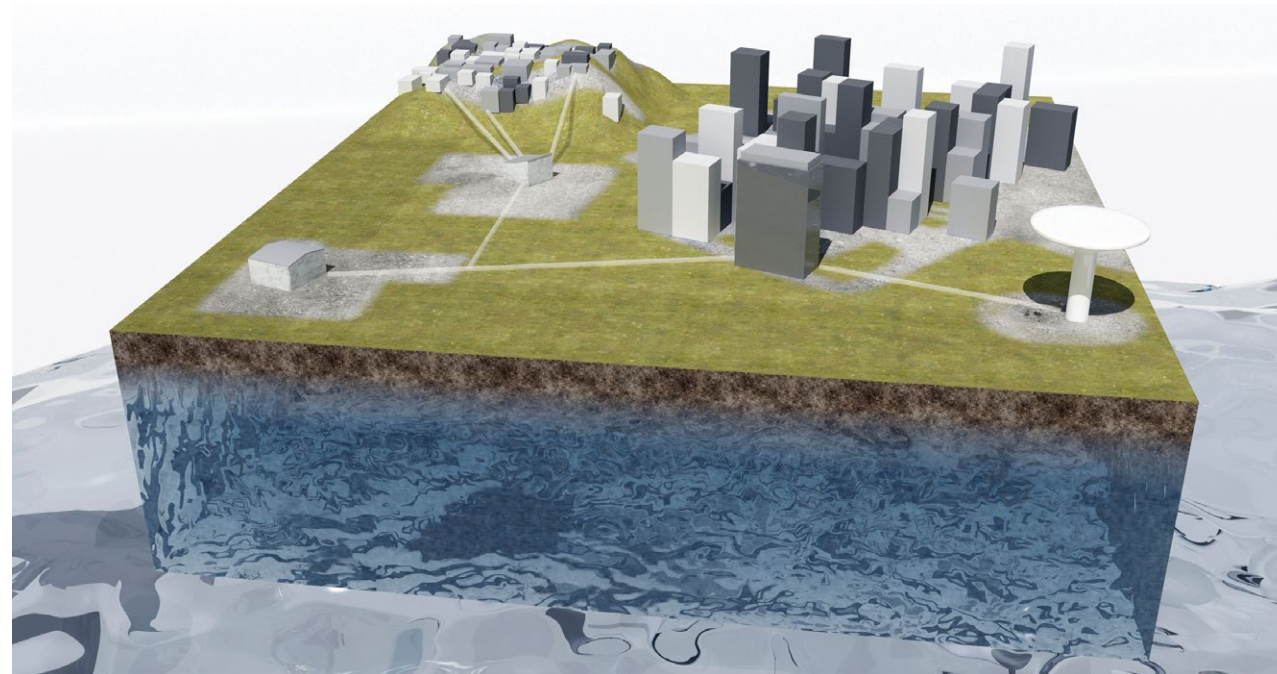

The reliable, clean and safe distribution of drinking water to homes and businesses is the obvious first priority of any water supplier. However, leakage and overflow can cost water companies much more than the water lost from the distribution system.

How water is distributed depends on topography and local regulation, and often a mix of gravity pipes and pressure pipes systems are used for the best results. Grundfos can supply pumps and controls for the entire water distribution system, including main and local pumping stations, ensuring reliable management of pressure zones throughout the pipes network.

Grundfos helps reduce costs and limit water loss in a water distribution system by effective pressure control. This is done by compensating for surplus pressure in the pipes system and by reducing water hammer which causes new holes.

Grundfos Demand Driven Distribution is a multi-pump solution operating at proportional pressure, where the system is designed to supply precisely the flow needed at the pressure required, with a number of pumps running at best efficiency point, instead of one big pump. The Grundfos Control MPC provides proportional pressure control, gradual ramp-up and ramp-down, the cascade operation of up to six pumps, and monitoring and control with clear text messages. The Grundfos Control MPC works with all pump types, offering substantial economic benefits from energy savings and reduced leakage losses.

The sustainability of water distribution systems from a source over time requires that the pumping solution is durable, ensuring cost effective and trouble-free operation. Grundfos has decades of experience developing controller and monitoring systems for pumping solutions and manufactures its own pump motors for all fluid types and flow requirements. This ensures a perfect match with hydraulics, motors, electrics, and all other mechanical components that make up a comprehensive pumping solution, ensuring the best possible efficiency point.

The high-efficiency motors developed by Grundfos, with or without an integrated or external variable frequency drive, meet and in some cases exceed the requirements set by motor-efficiency legislation around the world. Considering that on average 85% of a normal pump system's Life Cycle Cost (LCC) is energy costs, switching to high-efficiency motor technology can mean a LCC reduction of up to 50% and a reduction in environmental impact.

Control and monitoring systems increase the potential for improving both efficiency and reliability. Grundfos supplies external variable speed drives (Grundfos CUE), Dedicated Controls and internet-based supervision (GiC / GRM cloud) that are fully integrated into a pumping system. Dedicated Controls enable easy controlling of pump functionalities with an easy-to-use SCADA interface. Grundfos monitoring and control systems include plug-and-play communication interfaces that communicate with 95% of the communication standards available on the market.

17.1 PUMPING STATION



Ensuring the right balance between self-contained systems and pressure zones is a very important part of managing a water distribution system. The precision management of pressure zones offered by the Grundfos Hydro MPC range of

multistage pressure boosting systems using vertical multi-stage centrifugal pump (CR) pumps ensures system reliability and minimised system stress.

The Grundfos series of level controllers offers highly reliable monitoring and control for up to six pumps, and can work together with motor protection and frequency converters. A comprehensive range of sensor accessories – such as level, flow and temperature sensors – ensures that you have the data required for your pumps' control system.

Grundfos has developed a range of dedicated communication modules and controls to cover every eventuality, from sensors through BUS units to remote controls and customised software, we make sure you can get the data and control you want. Our products are all open protocol, so they work with the system you prefer.

Traditionally, chlorine compounds are the most widely used method for chemical disinfection. Grundfos can advise and supply disinfection solutions using chlorine compounds.

Grundfos can supply complete dosing pump systems for large or small volumes and based on different technologies for flocculation, disinfection, and pH adjustment. Moreover, the Grundfos range of electronic and electrochemical accessories offers complete control of your dosing and disinfection processes and can be seamlessly integrated into your system.

Pumping station		Features													Pumps														
Recommended product types: Dosing, level control, pressure control, flow control	Control (depend on connected sensor)	single pump duty / standby	parallel cascade operation	Non e-pump	Relay outputs	Grundfos GO communication	R100 Infrared communication	BACnet data communication	LONworks data communication	PROFIBUS DP/ PROFINET data communication	Modbus RTU data communication	EtherNet/IP data communication	Modbus TCP data communication	3G/4G cellular data communication	GiC/ GRM data communication	GENIBUS data communication	Ethernet (VNC Server) data communication	Night flow supervision / Remote pressure logging / wireless remote sensors	Sensor (0)4-20mA / 0-10V	Energy optimizing functions	Graphic display with user interface	Start-up wizard	Motor protection	CR	NB, NK, TP	HS; Peerless TU, LS	"SMART-Digital (DDE-P, DDC, DDA)	DDA Smart-XL, DME-AR, DMX/DMH-AR, DMX/DMH-AT"	
		E-pump CRE	S, F, Dt, T, P	x	x	*3		*4	x	x	*5	*5	*5	*5	*5	*5	*5												
E-pump CRE (MGE model H/I/J)	S, F, Dt, T, P	x	x	*3		*4	x	x	*5	*5	*5	*5	*5	*5	*5														
Hydro MPC (CU352)	P	x	x	x	*3		2	x	*9	*9	*9	*9	*9	*9	*9														
Control DDD ((CU 354))	Δp, PP, S, F, Dt, T, P	x	x	x		2	x	x	*9	*9	*9	*9	*9	*9	*9														
CUE (Frequency converter)	Δp, PP, S, F, Dt, T, P, L	x	x	*3		x	2	x	*10	*10	*10	*10	*10	*10	*10														
MP 204 (Motor protection)		x				x	1	x	x	*10	*10	*10	*10	*10	*10														
Dosing & disinfection	pH, Redox, Cl2, ClO2, O3, PAA, H2O2	x																											
Smart Digital S (DDE-PR), DDC, DDA										*7	*10	*10																	
Smart Digital XL (DDE-AR, DDA), DME-AR, DMX/DMH-AR, DMX/DMH-AT"																													

A= Autoadapt, Dp= Differential Pressure, P= Const. Pressure, PP= Proportional Pressure, T= Const. Temperature, DT= Differential Temperature, F= Const Flow, S= Const. Speed/Frequency, L=Level, pH=pH-Wert, Cl2= Chlorine, ClO2=Chlorine dioxid, O3=Ozone, PAA=Peracetic acid, H2O2=Hydrogen peroxide

*1) MAGNA3 cascade up to 2 pumps without ext. controller
 *2) TPED
 *3) E-pumps MGE model H/I/J cascade up to 2 pumps, with external Control MPC cascade up to 6 pumps possible. Note: data point "heat energy" only on twinpump available.

*4) All MGEs model H/I/J: 2 relay
 *5) MGE model H/I/J: CIM interfaces, TPED and MGE model F/G: CIU interfaces
 *6) version CIU xx2 needed
 *7) DDA:E-Box, DDA XL: CIU

*8) GENIBUSmodule MPC
 *9) CIM interfaces
 *10) CIU interfaces
 *11) incl. differential pressure sensor
 *12) 4-20 mA Sensor required x available

17.2 WATER TOWERS



Distribution from the water tower is often the final step before delivery to the consumer. Grundfos offers a user-friendly range of dosing pumps for those final adjustments, ensuring prime water quality.

Grundfos can supply complete dosing pump systems for large or small volumes and based on different technologies for flocculation, disinfection, and pH adjustment. Moreover, the Grundfos range of electronic and electrochemical accessories offers complete control of your dosing and disinfection processes and can be seamlessly integrated into your system.

Grundfos can advise and supply disinfection solutions using chlorine compounds. Grundfos monitoring and control systems e.g. Grundfos Remote management system increase the potential for improving both efficiency and reliability.

17.3 BOOSTING



The Grundfos range of electronic and electrochemical accessories offers complete control of your dosing and disinfection processes and can be seamlessly integrated into your system. HydroProtect from Grundfos is a compact ClO₂ disinfection system with an integrated booster station that can be tailored precisely for your requirements. HydroProtect is our solution for preventing the build-up of detectable organic chlorine compounds and is used extensively for water treatment in the food and beverage industry.

The Grundfos series of level controllers offers highly reliable monitoring and control for up to six pumps, and can work together with motor protection and frequency converters. A comprehensive range of sensor accessories – such as level, flow and temperature sensors – ensures that you have the data required for your pumps' control system.

Pressure boosting requirements can vary; from small systems for remote villages to separate urban pressure zones that guarantee swift responses to contamination scenarios. The precision management of pressure zones offered by the Grundfos Hydro MPC range of multistage pressure boosting systems using vertical multistage centrifugal pump (CR) pumps ensures system reliability and minimised system stress.

The considered application of technology ensures the best possible fit to your pumping requirements. Grundfos submersible multistage pumps bring together pump controllers (Control MPC), external frequency converters (CUE) for variable speed drives, motor protection (MP204) to monitor motor conditions and adapt to changing conditions, and a flexible riser hose for keeping system friction to a minimum.

GRM / GIC system can monitor the status of the complete system.

Water towers		Features																Pump									
Recommended product types: Dosing, level control, pressure control	Control (depend on connected sensor)	single pump	parallel cascade operation	Relay outputs	Grundfos GO communication	R100 Infrared communication	BACnet data communication	LONWorks data communication	PROFIBUS DP/ PROFINET data communication	Modbus data communication	EtherNet/IP data communication	Modbus TCP data communication	3C/4G cellular data communication	GIC/ GRM data communication (Grundfos Remote Management)	GENibus data communication	Ethernet (VNC Server) data communication	No external sensor required	Sensor (0/4-20mA / 0-10V)	Energy optimizing functions	Graphic display with user interface	Start-up wizard	Motor protection	CR	INB, NIK	Peerless TU, LS	"SMART-Digital (DDE-P, DDC, DDA)	DDA Smart-XL, DME-AR, DMX/DMH-AR, DMX/DMH-AT"
		E-pump CRE	S,F,Dt,T,P	x	x	*3)	*4)	x	x	*5)	*5)	*5)	*5)	*5)	*5)	*5)	*5)			x	x	x	x	x			
E-pump CRE (MGE model H/I/J)	S,F,Dt,T,P	x	x	x,*3)	2	x	x	*5)	*5)	*5)	*5)	*5)	*5)	*5)	*5)			x	x	x	x	x					
Hydro Multi-B	P	x	x	2		*9)	*9)	*9)	*9)	*9)	*9)	*9)	*9)	*9)	*9)	x		x	x	x	x	x					
Hydro MPC (CU352)	P	x	x	2		*9)	*9)	*9)	*9)	*9)	*9)	*9)	*9)	*9)	*9)	x		x	x	x	x	x					
Control MPC (CU352)	Δp,PP,S,F,Dt,T,P	x	x	x	2		*9)	*9)	*9)	*9)	*9)	*9)	*9)	*9)	*9)	x		x	x	x	x	x					
CUE (Frequency converter)	Δp,PP,S,F,Dt,T,P,L	x	x	*3)	x	2		*10)	*10)	*10)	*10)	*10)	*10)	*10)	*10)	x		x	x	x	x	x	x	x			
MP 204 (Motor protection)		x			x	1	x	x		*10)	*10)	*10)	*10)	*10)	x			x	x	x	x	x	x	x			
dosing& disinfection	pH, Redox, Cl ₂ , ClO ₂ , O ₃ , PAA, H ₂ O ₂	x																								x	
Smart Digital S (DDE-P(R), DDC, DDA) Smart Digital XL (DDE-AR, DDA), DME-AR, DMX/DMH-AR, DMX/ DMH-AT"																											

A= Autoadapt, Dp= Differential Pressure, P= Const. Pressure, PP= Proportional Pressure, T= Const. Temperature, Dt= Differential Temperature, F= Const Flow, S= Const. Speed/Frequency, L=Level, pH=pH-Wert, Cl₂= Chlorine, ClO₂=Chlorine dioxide, O₃=Ozone, PAA=Peracetic acid, H₂O₂=Hydrogen peroxide

- *1) MAGNA3 cascade up to 2 pumps without ext. controller
- *2) TPED
- *3) E-pumps MGE model H/I/J cascade up to 2 pumps, with external Control MPC cascade up to 6 pumps possible. Note: data point "heat energy" only on twinpump available.
- *4) All MGEs model H/I/J: 2 relay
- *5) MGE model H/I/J: CIM interfaces, TPED and MGE model F/G: CIU interfaces
- *6) version CIU xx2 needed
- *7) DDA:E-Box, DDA XL: CIU
- *8) GENibusmodule MPC
- *9) CIM interfaces
- *10) CIU interfaces
- *11) incl. differential pressure sensor
- *12) 4-20 mA Sensor required x available

Boosting		Features																Pump									
Recommended product types: Dosing, level control	Control (depend on connected sensor)	single pump	parallel cascade operation	Relay outputs	Grundfos GO communication	R100 Infrared communication	BACnet data communication	LONWorks data communication	PROFIBUS DP/ PROFINET data communication	Modbus data communication	EtherNet/IP data communication	Modbus TCP data communication	3C/4G cellular data communication	GIC/ GRM data communication (Grundfos Remote Management)	GENibus data communication	Ethernet (VNC Server) data communication	No external sensor required	Sensor (0/4-20mA / 0-10V)	Energy optimizing functions	Graphic display with user interface	Start-up wizard	Motor protection	CR	INB, NIK	Peerless TU, LS	"SMART-Digital (DDE-P, DDC, DDA)	DDA Smart-XL, DME-AR, DMX/DMH-AR, DMX/DMH-AT"
		E-pump CRE	S,F,Dt,T,P	x	x	*3)	*4)	x	x	*5)	*5)	*5)	*5)	*5)	*5)	*5)	*5)			x	x	x	x	x			
E-pump CRE (MGE model H/I/J)	S,F,Dt,T,P	x	x	x,*3)	2	x	x	*5)	*5)	*5)	*5)	*5)	*5)	*5)	*5)			x	x	x	x	x					
Hydro Multi-S	P	x	x	1																							
Hydro Multi-E (MGE model H/I/J)	P	x	x	2		x	*5)	*5)	*5)	*5)	*5)	*5)	*5)	*5)	*5)			x	x	x	x	x					
Hydro Multi-B	P	x	x	2		*9)	*9)	*9)	*9)	*9)	*9)	*9)	*9)	*9)	*9)	x		x	x	x	x	x					
Hydro MPC (CU352)	P	x	x	x	2		*9)	*9)	*9)	*9)	*9)	*9)	*9)	*9)	*9)	x		x	x	x	x	x					
Control MPC (CU352)	Δp,PP,S,F,Dt,T,P	x	x	x	2		*9)	*9)	*9)	*9)	*9)	*9)	*9)	*9)	*9)	x		x	x	x	x	x					
CUE (Frequency converter)	Δp,PP,S,F,Dt,T,P,L	x	x	*3)	x	2		*10)	*10)	*10)	*10)	*10)	*10)	*10)	*10)	x		x	x	x	x	x	x	x			
MP 204 (Motor protection)		x			x	1	x	x		*10)	*10)	*10)	*10)	*10)	x			x	x	x	x	x	x	x			
dosing& disinfection	pH, Redox, Cl ₂ , ClO ₂ , O ₃ , PAA, H ₂ O ₂	x																								x	
Smart Digital S (DDE-P(R), DDC, DDA) Smart Digital XL (DDE-AR, DDA), DME-AR, DMX/DMH-AR, DMX/ DMH-AT"																											

A= Autoadapt, Dp= Differential Pressure, P= Const. Pressure, PP= Proportional Pressure, T= Const. Temperature, Dt= Differential Temperature, F= Const Flow, S= Const. Speed/Frequency, L=Level, pH=pH-Wert, Cl₂= Chlorine, ClO₂=Chlorine dioxide, O₃=Ozone, PAA=Peracetic acid, H₂O₂=Hydrogen peroxide

- *1) MAGNA3 cascade up to 2 pumps without ext. controller
- *2) TPED
- *3) E-pumps MGE model H/I/J cascade up to 2 pumps, with external Control MPC cascade up to 6 pumps possible. Note: data point "heat energy" only on twinpump available.
- *4) All MGEs model H/I/J: 2 relay
- *5) MGE model H/I/J: CIM interfaces, TPED and MGE model F/G: CIU interfaces
- *6) version CIU xx2 needed
- *7) DDA:E-Box, DDA XL: CIU
- *8) GENibusmodule MPC
- *9) CIM interfaces
- *10) CIU interfaces
- *11) incl. differential pressure sensor
- *12) 4-20 mA Sensor required x available

18. WASTEWATER TRANSPORT

MUNICIPAL WATERWORKS

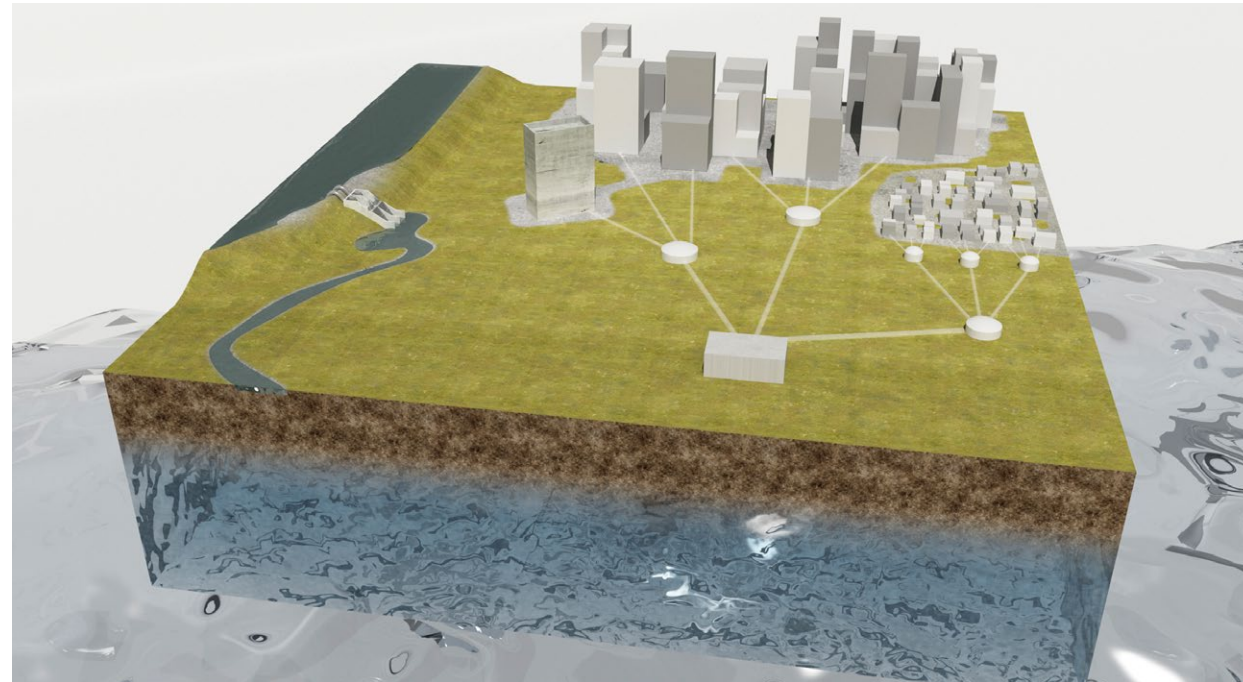

Compared to a water supply system that distributes water and ensures sufficient pressure at the end-user, transporting wastewater requires a wide range of pumps to keep the wastewater moving in an environment of constantly varying pressure. Depending on topography and local regulation, a mix of gravity sewers and pressure sewerage systems may be required.

Grundfos can cover all eventualities, from large-scale, fully-customised pumping stations to complete prefabricated submersible pumping stations; from large axial and mixed-flow pumps that can cope with moving vast flows of surface or storm water at low head to sewage grinder pumps for pressurised systems with small amounts of water and small lifting stations for transporting effluent away from remote communities.. Furthermore, Grundfos supplies complete control and monitoring solutions.

Grundfos solutions are designed specifically for pumping installations and all the components are fully integrated from the start. The sustainability of wastewater transport over time requires that the pumping solution is durable, ensuring cost effective and trouble-free operation.

Experience with system design means Grundfos can ensure energy optimisation solutions that do not compromise reliability, is able to keep your pumps running during replacement

or refurbishment projects, and builds in risk minimisation and sustainability into solutions. This is done, for example, with Computational Fluid Dynamics (CFD) simulations at the design phase, Life Cycle Cost analyses for entire pump systems, and pump audits for energy optimisation.

The high-efficiency motors developed by Grundfos combined with dedicated variable speed drives meet and in some cases exceed the requirements set by motor-efficiency legislation around the world. Considering that on average 85% of a normal pump system's Life Cycle Cost (LCC) is energy costs, switching to high-efficiency motor technology can mean a LCC reduction of up to 50% and a reduction in environmental impact.

Control and monitoring systems increase the potential for improving both efficiency and reliability. Grundfos supplies external variable speed drives (Grundfos CUE), Dedicated Controls and internet-based supervision system (GRM/ GiC cloud) that are fully integrated into a pumping system. Dedicated Controls allows customization and easy controlling of typical and special pump functionalities such as energy optimisation and anti-blocking with an easy-to-use SCADA interface. Grundfos monitoring and control systems include plug-and-play communication interfaces that communicate with 95% of the communication standards available on the market.

18.1 MAIN PUMPING STATIONS



Pumping stations in wastewater transport systems are designed to handle raw sewage that is fed from underground gravity pipelines or network pumping stations. Main pumping stations are typically designed so that one pump or one set of pumps so that multiple pumps, sometimes of different capacities, will handle normal peak flow conditions. Many main wastewater pumping stations operate with dry-installed pump systems, although submerged pump systems can offer many advantages for reduced operation costs, enhanced reliability and less infrastructure investment. Grundfos is able to supply complete pumping solutions for both dry and submerged installations.

From small to large-scale pumping systems for upgrade of existing installation to new projects, Grundfos can supply total solutions completed with pumps, valves, switchboard,

instrumentation and control to ensure full compatibility, best efficiency and easy to service.

When designing a pumping system, Grundfos specialists can apply Computational Fluid Dynamics (CFD) simulations and surge analysis to depict accurately fluid flow and pressure graphically at any location in the pump system. This means that we are able to discover flow problems and recommend best solution even before construction begins. Pump pits designed to function well at both low and high flows ensure self-cleaning and reduce wear and smell by continuously removing deposits and solids. Using surge analysis, potential water hammer in the system can be identified to avoid future damages.

The Grundfos ranges S, SE/SL, SD, KPL and KWM pumps are specially designed for durability to handle heavily fluctuating sewage flows and can be installed dry or submerged.

Control and monitoring systems with GRM / GiC cloud significantly reduce routine inspections and increase the potential for improving both efficiency and reliability. Grundfos supplies pump starters and external variable speed drives (Grundfos CUE), Dedicated Controls for easy control of pump functionalities, and internet-based supervision (Grundfos Remote Management) with an easy-to-use SCADA interface.

Grundfos monitoring and control systems include plug-and-play communication interfaces that work with 95% of the communication standards available on the market. A comprehensive range of sensor accessories – such as level, flow and temperature sensors – ensures that you have the data required for your pumps' control system, required for best monitoring and control of your pumping system.

Main pumping stations		Features													Pumps													
Recommended product types: Dosing, level control	Control (depend on connected sensor)	single pump	parallel cascade operation	Non e-pump	Relay outputs	Grundfos GO communication	R100 Infrared communication	BACnet data communication	LONWorks data communication	PROFIBUS DP/ PROFINET data communication	Modbus data communication	EtherNet/IP data communication	Modbus TCP data communication	3G/4G cellular data communication	GiC/ GRM data communication (Grundfos Remote Management)	GENibus data communication	Ethernet (VNC Server) data communication	No external sensor required	Sensor (0/4-20mA / 0-10V)	Energy optimizing functions	Graphic display with user interface	Start-up wizard	Motor protection	KWM, YCC	S	SE/SL	AMD, SMD	
		CUE (Frequency converter)	Δp, PP, S, F, Dt, T, P, L	x	x	*3	x	2				*10	*10	*10	*10	*10	*10	x			x	x	x	x	x	x	x	x
Dosing & disinfection	pH, Redox, Cl ₂ , ClO ₂ , O ₃ , PAA, H ₂ O ₂	x								DDA*7)	DDA*7)						DDA			x	x	x	x	x	x	x	x	x
Control DC (Dedicated Controls)	L	x	x	x	x	2				*9)	*9)			*9)	*9)	*9)	x			x	x	x	x	x	x	x	x	x
MP 204 (Motor protection)		x			x	1	x	x		*10)	*10)			*10)	*10)	x								x	x	x	x	x
IO113 signal converter		x																										
SM113 signal converter		x																										

A= Autoadapt, Dp= Differential Pressure, P= Const. Pressure, PP= Proportional Pressure, T= Const. Temperature, DT= Differential Temperature, F= Const Flow, S= Const. Speed/Frequency, L=Level, pH=pH-Wert, Cl₂= Chlorine, ClO₂=Chlorine dioxide, O₃=Ozone, PAA=Peracetic acid, H₂O₂=Hydrogen peroxide

*6) version CIU xx2 needed
 *7) DDA-E-Box, DDA XL: CIU
 *8) GENibusmodule MPC
 *9) CIM interfaces
 *10) CIU interfaces
 *11) incl. differential pressure sensor
 *12) 4-20 mA Sensor required
 x available

18.2 PRESSURIZED SYSTEMS



In areas with high water table, in scarcely populated areas, or where topography makes it difficult and expensive to build traditional gravity sewer systems, pressurized systems can be used as a reliable and cost-effective sewer system from individual households to public sewerage systems.

The SEG AutoAdapt sewage grinder is an example of an innovative Grundfos solution for pressurized pumping systems with integrated level sensor and pump control. In addition to efficient cutting of all material in the wastewater, the SEG AutoAdapt simplifies pump pit management and reduces costs, eliminating 75% of all service calls and reducing installation and commissioning costs by 50%.

Grundfos PS, which is a complete prefabricated pump station for pressurized system, is designed for easy transport, self cleaning with smooth surfaces, low maintenance and easy service. Grundfos grinder pumps used in PS are ideal for pressurized sewer systems, which demand efficient cutting, and are designed for durability in submerged operation pumping concentrated sewage.

Control and monitoring systems with GRM / GiC cloud significantly reduce routine inspections and increase the potential for improving both efficiency and reliability. GRM / GiC is an economic way to supervise vast numbers of small pump stations in remote areas.

Grundfos specialists can use software developed in-house to analysis loading and flow pattern to optimise pumps and pressure main sizing for best efficiency and reliability.

18.3 NETWORK AND PREFABRICATED PUMPING STATIONS



A network pumping station ensures collection and transport of wastewater to larger pumping stations. Grundfos can supply and customise a complete network pumping station to match your requirements for size and design. Grundfos can supply complete prefabricated pumping stations with submerged pumps systems, level sensors and control solutions, and dosing solutions can also be added.

Wastewater systems involve great fluctuations in demand for performance, and your pumping solutions must be able

to respond immediately when demand changes or incidents occur, protecting your system against the risk of water hammer, for example. The Grundfos pump ranges of SE/SL and S pumps used are specifically designed for durable use and heavy sewage flows and can be installed dry or submerged, while the SEG range of grinder pumps is ideal for pressurised sewage systems and is capable of continuous operation when fully submerged. Innovative Grundfos solutions, such as wastewater pumps with AutoAdapt functionality, simplify pump pit management and reduce costs, eliminating 75% of all service calls and reducing installation and commissioning costs by 50%.

The Grundfos Dedicated Controls level controllers offers highly reliable monitoring and control for up to six pumps, and can work together with motor protection and frequency converters. A comprehensive range of sensor accessories – such as level, flow and temperature sensors – ensures that you have the data required for your pumps' control system.

Dedicated Controls for pumping stations has anti-clogging functionality built-in. The “flush and reverse” function prevents clogging caused by the increasing amounts of the fibrous component in sewage today. The anti-clogging function acts on any abnormal events to stop pumps from blocking, avoiding costly downtime.

Pressurized systems		Features														Pumps													
Recommended product types: Dosing, level control	Control (depend on connected sensor)	single pump	duty / standby	parallel cascade operation	Non e-pump	Relay outputs	Grundfos GO communication	R100 Infrared communication	BACnet data communication	LONWorks data communication	PROFIBUS DP/ PROFINET data communication	Modbus RTU data communication	EtherNet/IP data communication	Modbus TCP data communication	3G/4G cellular data communication	GiC/ GRM data communication (Grundfos Remote Management)	GENibus data communication	Ethernet (VNC Server) data communication	No external sensor required	Sensor (0/4-20mA / 0-10V)	Energy optimizing functions	Graphic display with user interface	Start-up wizard	Motor protection	DP, EF	SE, SEG, SL	SEG AutoAdapt	Grundfos Pumping Stations (PS)	
		LC / LCD	L	x	x	x	x	1																					
Control DC (Dedicated Controls)	L	x	x	x	x	2				*9)	*9)	*9)	*9)	*9)	*9)	*9)	x		x	x	x	x	x	x	x	x	x	x	
MP 204 (Motor protection)		x			x	x	x			*10)	*10)	*10)	*10)	*10)															
IO113 signal converter		x																						x					
SM113 signal converter		x																											
SEG AutoAdapt	L	x	x	x	1	*6)	*6)			*6)	*6)	*6)	*6)	*6)	*6)			x											
Prefabricated pumping station	L	x	x	x	x														x	x	x	x	x	x	x	x	x	x	x
Dosing & disinfection	H2S prevention	x																											

A= Autoadapt, Dp= Differential Pressure, P= Const. Pressure, PP= Proportional Pressure, T= Const. Temperature, DT= Differential Temperature, F= Const Flow, S= Const. Speed/Frequency, L=Level, pH=pH-Wert, Cl2= Chlorine, ClO2=Chlorine dioxide, O3=Ozone, PAA=Peracetic acid, H2O2=Hydrogen peroxide

*6) version CIU xx2 needed
 *7) DDA:E-Box, DDA XL: CIU
 *8) GENibusmodule MPC
 **9) CIM interfaces
 10) CIU interfaces
 *11) incl. differential pressure sensor
 *12) 4-20 mA Sensor required
 x available

Network and prefabricated pumping stations		Features														Pumps													
Recommended product types: Level control	Control (depend on connected sensor)	single pump	duty / standby	parallel cascade operation	Non e-pump	Relay outputs	Grundfos GO communication	R100 Infrared communication	BACnet data communication	LONWorks data communication	PROFIBUS DP/ PROFINET data communication	Modbus RTU data communication	EtherNet/IP data communication	Modbus TCP data communication	3G/4G cellular data communication	GiC/ GRM data communication (Grundfos Remote Management)	GENibus data communication	Ethernet (VNC Server) data communication	No external sensor required	Sensor (0/4-20mA / 0-10V)	Energy optimizing functions	Graphic display with user interface	Start-up wizard	Motor protection	S	SE, SL, SEG	SEG AutoAdapt	Grundfos Pumping Stations	
		CUE (Frequency converter)	Δp,PP,S,F,Dt,T,P,L	x	x	*3)	x	2				*10)	*10)	*10)	*10)	*10)	*10)	*10)	x			x	x	x	x	x	x	x	x
Control DC (Dedicated Controls)	L	x	x	x	2					*9)	*9)	*9)			*9)	*9)	x			x	x	x	x	x	x	x	x	x	
LC / LCD	L	x	x	x	1																								
MP 204 (Motor protection)					x	x	x								*10)	*10)	*10)												
IO113 signal converter																													
SM113 signal converter																													
SEG AutoAdapt	L	x	x		1	*6)	*6)			*6)	*6)	*6)			*6)	*6)			x										
Prefabricated pumping station	L	x	x		x															x	x	x	x	x	x	x	x	x	x
Dosing & disinfection	H2S prevention	x																											

A= Autoadapt, Dp= Differential Pressure, P= Const. Pressure, PP= Proportional Pressure, T= Const. Temperature, DT= Differential Temperature, F= Const Flow, S= Const. Speed/Frequency, L=Level, pH=pH-Wert, Cl2= Chlorine, ClO2=Chlorine dioxide, O3=Ozone, PAA=Peracetic acid, H2O2=Hydrogen peroxide

*6) version CIU xx2 needed
 *7) DDA:E-Box, DDA XL: CIU
 *8) GENibusmodule MPC
 **9) CIM interfaces
 10) CIU interfaces
 *11) incl. differential pressure sensor
 *12) 4-20 mA Sensor required
 x available

18.4 FLOOD CONTROL

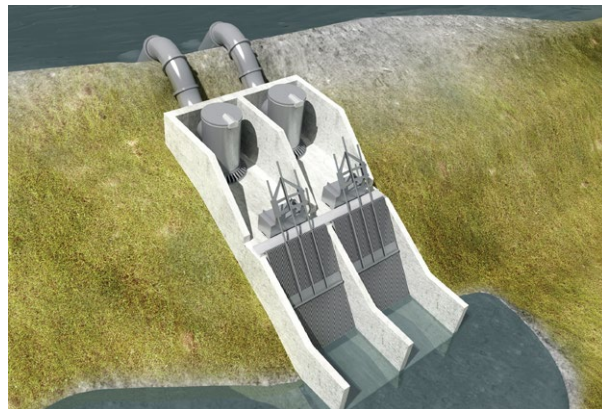

Flood control is not just flood control. but Coastal guards, Stormwater tanks, Equalisation tanks and Flood gates.

Limiting the potential damage of coastal and inland flooding requires a pump system that won't fail when required. There's a lot at stake - initially, protection of people, crops and livestock, and in the longer term preventing contamination, damage to infrastructure and the potential risk of famine. Ensuring that flood events can be controlled often requires careful planning. The Grundfos ranges of submersible pumps are specifically designed with the reliability and robustness in mind needed for flood control.

- Axial flow pumps, KPL
- Mixed-flow pumps, KWM
- Centrifugal pumps, S/SE/SL and the later can be installed dry as well.

Stormwater tanks are an effective way of reducing peak flow and equalizing flow rates from storm water runoffs in the sewer system. Placed strategically, stormwater tanks mean better utilization of the existing sewer system, allow for intelligent management of storm water flows, and ultimately save on infrastructure investments. Stormwater tanks can be built to almost any size and shape. The inlet and outlet can be managed by gravity, by a pump system or a combination of both, depending on hydraulic conditions in the system. Grundfos offers a range of pumping and control solutions as well as mixers and cleaning equipment that together ensure reliable and automatic operation of the stormwater tank. Once the hydraulic load is reduced and capacity is available, you can get wastewater moving again with perfect efficiency. The Grundfos range of level sensor accessories ensures that your pump system can control possible fluctuations in demand for performance. This ensures the optimum delivery of wastewater to and from the stormwater tank. Efficient mixing and cleaning of equalization tanks is essential to minimize operation costs and avoid odour problems. The Grundfos range of RainJets is especially designed for this purpose, offering a robust construction and easy service and maintenance. The RainJets can work either alone or together with the robust and durable SMD/SMG mixer.

Grundfos supplies a new efficient FLOOD MITIGATION CONTROLLER (FMC) to ensure the energy saving and efficient operation of complex pumping solution.

Less cost compared to existing control system

- Saving energy consumption
- Flexibility and expandability
- Wireless control
- Easy maintenance
- Data storage
- Unique solution by pump station specialist
- User friendly interface (Touch screen)
- Grundfos One stop solution provider

19. WASTEWATER TREATMENT MUNICIPAL WASTEWATER

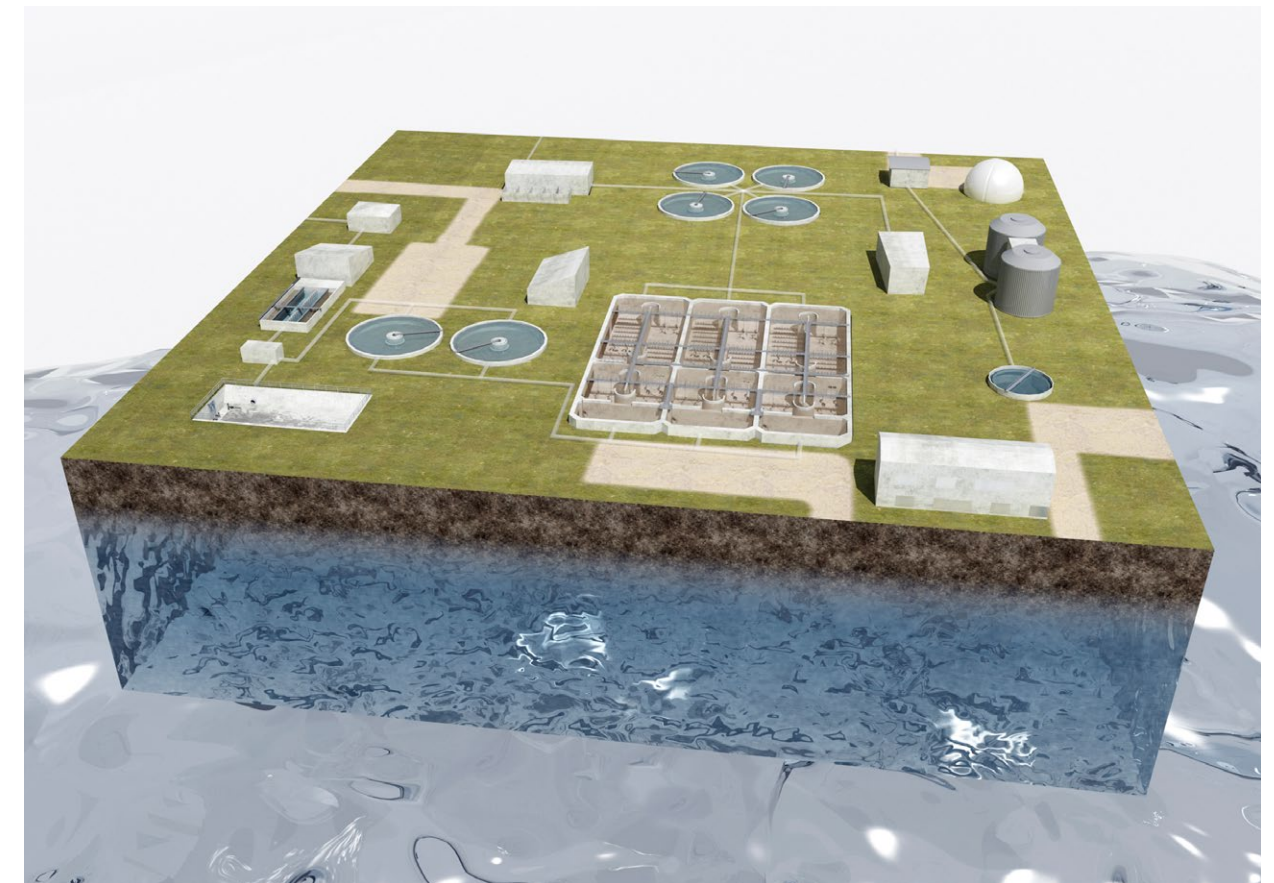

Wastewater treatment is the process of removing contaminants from water discharged from domestic, industrial or commercial premises as well as surface run-off. Wastewater treatment typically utilises mechanical, biological, and chemical processes to remove these contaminants. Grundfos can supply a whole range of components for a complete mechanical, biological, and chemical wastewater treatment plant.

The process of wastewater treatment varies from simple tanks, relying solely on sedimentation, to the refined treatment processes with advanced biological and tertiary treatment that we know today. Treatment aims at reducing the pollution contained in the wastewater such as bacteria and viruses, oxygen consuming components, nutrients, pharmaceuticals, chemical substances and heavy metals from wastewater before it is discharged to the receiving waters.

Grundfos has decades of experience developing controller and monitoring systems for pumping, dosing and disinfection solutions and manufactures its own pump motors for

all fluid types and flow requirements. This ensures a perfect match with process requirement, hydraulics, motors, electricals, and all other mechanical components that make up a comprehensive package solution to ensure full compliance with treatment requirements and best possible efficiency.

Control and monitoring is a critical part of the treatment process. Grundfos supplies online analytical instruments to provide data for control of important operation parameters including bacteria counts and residual chlorine.

The high-efficiency motors developed by Grundfos, with or without an integrated or external variable frequency drive, meet and in some cases exceed the requirements set by motor-efficiency legislation around the world. Considering that on average 85% of a normal pump system's Life Cycle Cost (LCC) is energy costs, switching to Grundfos pumps with high-efficiency motor technology can mean a LCC reduction of up to 50% and a reduction in environmental impact.

Flood control		Features																Pumps										
Recommended product types: Level control	Control (depend on connected sensor)	single pump	parallel cascade operation	Non e-pump	Relay outputs	Grundfos GO communication	RTIO Infrared communication	BACnet data communication	LONWorks data communication	PROFIBUS DP/ PROFINET data communication	Modbus RTU data communication	EtherNet/IP data communication	Modbus TCP data communication	3C/4G cellular data communication	GIC/ GRM data communication (Grundfos Remote Management)	GENibus data communication	Ethernet (VNC Server) data communication	No external sensor required	Sensor (0/4-20mA / 0-10V)	Energy optimizing functions	Graphic display with user interface	Start-up wizard	Motor protection	S	SE,SL	KPL, KWM	SMD, SMG	
		CUE (Frequency converter)	Δp,PP,S,F,DT,T,P,L	x	x	*3	x	2		*10	*10	*10	*10	*10	*10	*10	*10	x		x	x	x	x	x	x	x	x	x
Control DC (Dedicated Controls)	L	x	x	x	x	2				*9	*9		*9	*9	*9	*9	x		x	x	x	x	x	x	x	x	x	x
LC / LCD	L	x	x	x	x	1																						
MP 204 (Motor protection)		x			x	x	x			*10	*10		*10	*10	*10	x									x	x	x	x
IO113 signal converter		x																							x	x	x	x
SM113 signal converter		x																							x	x	x	x
FMC		x	x	x	x	x									x									x	x	x	x	x

A= Autoadapt, Dp= Differential Pressure, P= Const. Pressure, PP= Proportional Pressure, T= Const. Temperature, DT= Differential Temperature, F= Const Flow, S= Const. Speed/Frequency, L=Level, pH=pH-Wert, Cl2= Chlorine, ClO2=Chlorine dioxide, O3=Ozone, PAA=Peracetic acid, H2O2=Hydrogen peroxide

*6) version CIU xx2 needed
 *7) DDA-E-Box, DDA XL: CIU
 *8) GENibusmodule MPC
 **9) CIM interfaces

10) CIU interfaces
 *11) incl. differential pressure sensor
 *12) 4-20 mA Sensor required
 x available

19.3 MECHANICAL TREATMENT

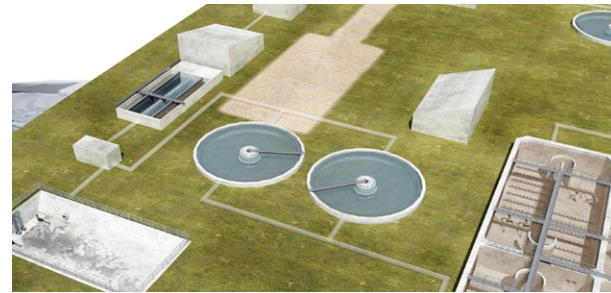

Raw wastewater has a high content of inorganic materials, such as toilet paper, textiles, napkins, as well as plastic bags, pieces of wood. Such materials must be removed as the first part of the treatment process. The screening station is therefore the first step in the mechanical treatment of wastewater. Effective washing of the detained material to remove organic matters will reduce the amount of disposal significantly and prevent odour problems. Grundfos offers pump and control solutions for the effective backwash of the screens, ensuring reliable operation of your screening station.

The Grundfos Hydro MPC range of multistage pressure boosting systems means you can manage your pressure zones with ease, and together with our range of level sensor accessories will ensure effective washing of the entire screening station.

Once wastewater has been screened for the removal of large materials, mechanical treatment's next step is the removal of grit and grease. Removing these prior to commencing biological treatment of wastewater is essential for ensuring the smooth operation of the wastewater treatment plant. Grundfos pumps can be used to pump settled grit and can be installed dry or submerged. They offer the reliability you need to ensure safe operation. Diffuser systems from Grundfos offer fine or coarse bubble diffusers for large air flows for the separation processes of the grit and grease removal.

The equalisation tank is where excess wastewater can be stored during heavy rain. Equalisation tanks can be an effective way of cost-optimising the wastewater treatment plant as this allows for the construction of smaller tanks for treatment and ensures a steady hydraulic load through the plant.

Equalisation tanks can be built to almost any size and shape. The inlet and outlet can be managed by gravity, by a pump system or a combination of both, depending on hydraulic conditions in the system. Grundfos has the pumps to cope with these heavy demands. The Grundfos ranges of SE/SL, S and KPL/KWM pumps are specifically designed for durable use with heavy flows and can be installed dry or submerged. The Grundfos range of level sensor accessories ensures that your pumps system can control possible fluctuations in demand for performance. This ensures the optimum delivery of wastewater to and from the equalisation tank.

Control and monitoring systems increase the potential for improving both efficiency and reliability. In addition to variable speed drives (Grundfos CUE), Grundfos supplies motor protection (MP204) to monitor motor conditions, ensuring optimal operation.

Mechanical treatment		Features																Products										
Recommended product types: Dosing, level control, pressure control, flow control	Control (depend on connected sensor)	single pump duty / standby	parallel cascade operation	Non e-pump	Relay outputs	Grundfos GO communication	R100 Infrared communication	BACnet data communication	LONWorks data communication	PROFIBUS DP/ PROFINET data communication	Modbus RTU data communication	EtherNet/IP data communication	Modbus TCP data communication	3C/4G cellular data communication	GIC/ GRM data communication (Grundfos Remote Management)	GENibus data communication	Ethernet (VNC Server) data communication	No external sensor required	Sensor (0)4-20mA / 0-10V	Energy optimizing functions	Graphic display with user interface	Start-up wizard	Motor protection	SMG, SMD	KPL, KWM	S, SE, SL	"SMART-Digital (DDE-P, DDC, DDA) DDA Smart XL DME-AR DMX/DMH-AR DMX/DMH-AT"	
		CUE (Frequency converter)	Δp, PP, S, F, Dt, T, P, L	x	x	*3	x	2			*10	*10	*10	*10	*10	*10	*10	*10	x		x	x	x	x	x	x	x	x
Control DC (Dedicated Controls)	L	x	x	x	x	2																						
MP 204 (Motor protection)		x			x	1	x	x																				
Polydos & disinfection	pH, Redox, Cl2, ClO2, O3, PAA, H2O2	x																										
IO113 signal converter		x																										
SM113 signal converter		x																										
Hydro MPC (CU352)	P	x	x	x	2																							
Smart Digital S (DDE-P(R), DDC, DDA) Smart Digital XL (DDE-AR, DDA), DME-AR, DMX/DMH-AR, DMX/DMH-AT"																												
Aeration																												

A= Autoadapt, Dp= Differential Pressure, P= Const. Pressure, PP= Proportional Pressure, T= Const. Temperature, DT= Differential Temperature, F= Const Flow, S= Const. Speed/Frequency, L=Level, pH=pH-Wert, Cl2= Chlorine, ClO2=Chlorine dioxide, O3=Ozone, PAA=Peracetic acid, H2O2=Hydrogen peroxide

*6) version CIU xx2 needed
 *7) DDA-E-Box, DDA XL: CIU
 *8) GENibusmodule MPC
 **9) CIM interfaces
 10) CIU interfaces
 *11) incl. differential pressure sensor
 *12) 4-20 mA Sensor required
 x available

19.4 WWTP - INLET STATIONS



The wastewater entering at a wastewater treatment plant's inlet pumping station contains all substances that have entered the sewer system. This is not only what we flush down the toilet, but also industrial effluents, wastewater from hotels, hospitals and restaurants, and substances drawn directly into the sewer system through manholes.

The Grundfos pump ranges S, SE/SL, YCC and KWM pumps are specially designed for durability to handle heavily fluctuating sewage flows and can be installed dry or submerged. If the design of the pump sump does not prevent sedimentation, the Grundfos range of robust AMD mixers ensure full mixing and thereby ensure trouble-free operation and prevent odours.

The inlet pumping station involves great fluctuations in demand for performance. With multiple inlet pumps installed, adding external variable speed drives (Grundfos CUE) will equalize the hydraulic load to the wastewater treatment plant. Computational Fluid Dynamics (CFD) simulations at the design phase helps ensure the optimum delivery of wastewater through the inlet pumping station for mechanical treatment by visualising hydraulic conditions at the pumping station.

Grundfos Dedicated Controls provides vital operation data to WWTP SCADA system for overall plant control while manages operation of the entire pump station. Together with built-in pump sensors and external instruments, the high level of control capability and complete monitoring of the pumps and system improves efficiency, reliability and ensure optimal operation.

WWTP inlet stations		Features																Products									
Recommended product types: Dosing, level control	Control (depend on connected sensor)	single pump duty / standby	parallel cascade operation	Non e-pump	Relay outputs	Grundfos GO communication	R100 Infrared communication	BACnet data communication	LONWorks data communication	PROFIBUS DP/ PROFINET data communication	Modbus RTU data communication	EtherNet/IP data communication	Modbus TCP data communication	3C/4G cellular data communication	GIC/ GRM data communication (Grundfos Remote Management)	GENibus data communication	Ethernet (VNC Server) data communication	No external sensor required	Sensor (0)4-20mA / 0-10V	Energy optimizing functions	Graphic display with user interface	Start-up wizard	Motor protection	YCC pumps	S, SE, SL	KWM	SMD, SMG
		CUE (Frequency converter)	Δp, PP, S, F, Dt, T, P, L	x	x	*3	x	2				*10	*10	*10	*10	*10	*10	*10	x		x	x	x	x	x	x	x
Control DC (Dedicated Controls)	L	x	x	x	x	2																					
LC / LCD	L	x	x	x	x	1																					
MP 204 (Motor protection)		x			x	x	x																				
IO113 signal converter		x																									
SM113 signal converter		x																									

A= Autoadapt, Dp= Differential Pressure, P= Const. Pressure, PP= Proportional Pressure, T= Const. Temperature, DT= Differential Temperature, F= Const Flow, S= Const. Speed/Frequency, L=Level, pH=pH-Wert, Cl2= Chlorine, ClO2=Chlorine dioxide, O3=Ozone, PAA=Peracetic acid, H2O2=Hydrogen peroxide

*6) version CIU xx2 needed
 *7) DDA-E-Box, DDA XL: CIU
 *8) GENibusmodule MPC
 **9) CIM interfaces
 10) CIU interfaces
 *11) incl. differential pressure sensor
 *12) 4-20 mA Sensor required
 x available

21. SOLAR WATER SOLUTION

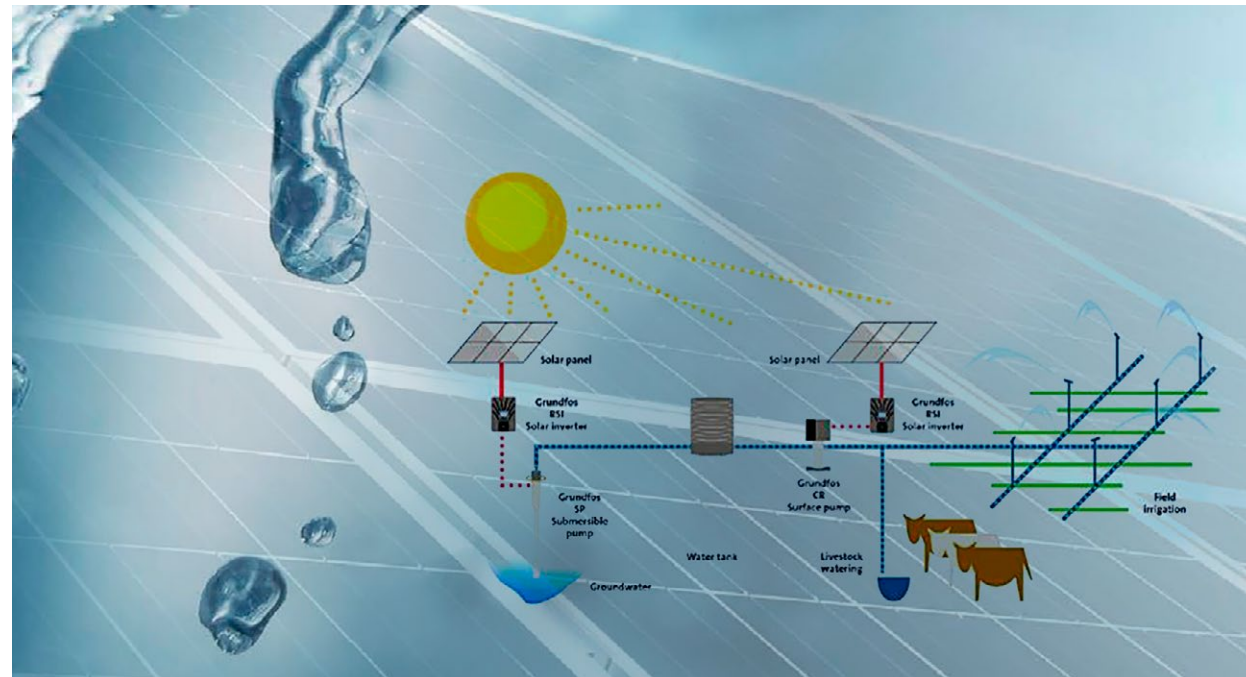

Renewable pumping : SQFlex / CU200 / GRM CIU273 SQFlex:

Flexible and sustainable water supply using clean energy. Clean energy increasingly the preferred choice for water supply. In recent years, the cost of generating clean energy from renewable sources has decreased sharply. At the same time, governments around the world are insisting that a greater proportion of energy is generated from renewable sources. The drive to increase motor efficiency and reduce CO2 emissions has led to increasing regulation as to how energy is generated. This is a trend that is set to continue.

Solar submersible pumping systems from Grundfos present a cost effective, flexible and secure water supply solution using clean energy. Utilising solar power saves on energy costs and on the costs of energy infrastructure, wherever the application is installed.

Solar submersible pumps offer tangible benefit

> Easy installation Solar submersible pumping systems can be tailored to your application and local conditions. Supplied as a plug-and-go solution, the solar submersible pumping systems are remarkably easy to install and use under even the most difficult conditions.

> Extend pump lifetime The built-in protection features for the pump motor ensure a low maintenance solar submersible pumping solution.

> Cost-efficient pumping Designed for continuous as well as intermittent operation, solar submersible pumping systems are especially suitable where cost is all-important. Once the initial investment in the system is made, operating costs are low. Solar submersible pumping systems are ideal for irrigation, livestock and fish farming, and for water supply.

Grundfos Solar water solutions a solid investment

Grundfos pumping systems using renewable energy sources provide the perfect sustainable, reliable and cost-efficient alternative to grid-based systems, with substantial benefits for your investment. Bringing down lifecycle costs. The lifecycle costs of a Grundfos submersible solar pumping solution will be considerably lower than with other water supply systems, because you can save substantial sums on reduced maintenance costs and no energy costs. Typically, the lifecycle costs for a grid-based pump system would include the following elements:

- > Initial purchase price of the pump and all system components
- > Operating costs, of which energy is usually the largest single cost item
- > Service agreement ensuring correct system sizing, high pump efficiency and performance, technical advice, service and reliable logistics.

For a Grundfos renewable energy-based system, the initial purchase price is the greatest investment. Once the pumping system is installed, you no longer get energy bills, meaning a rapid pay-back time on the initial investment.

The benefits of a relationship with Grundfos mean that that the pumping system is sized, configured or packaged to fit your application right from the start, reducing costs for installation, commissioning and service.

You cannot afford not to invest solar water solutions are a good investment. Governments increasingly encourage investors to choose renewable energy in new installations, and there is a growing awareness of the low risk of such investments. This is because the installation is not dependent on energy prices staying low to ensure a payback on the investment.

21.1 SOLAR WATER SOLUTION



Monitoring and Control options:

CU200 SQFlex

CU200 is designed for SQFlex range for automatic control of tanklevel / water reservoir and on-site monitoring of SQFlex power consumption and service indication. CU200 is simple in installation and operation.

CIU 283 GRM SQFlex

CIU 283 GRM SQFlex is designed for the SQFlex range for automatic control of tanklevel / water reservoir and monitoring via either R100(Grundfos GO) or GRM / GiC . With CIU 283 GRM SQFlex you get the features of start/stop switch, level switch and pulsating water meter, it also possible to adjust the maximum speed of the SQFlex in case of a low yield well, to avoid over pumping the well.

CIU 283 GRM SQFlex is especially suitable as monitoring unit for SQFlex in remote areas, so you can see the system performance, and giving the possibility to react if something changes in performance or stop in operation, so service can be requested before loss of animals or crop production.

CIU 903 SQFlex

CIU 903 Same as CIU 283 without GRM

Renewable Solar Inverter (RSI):

Designed to power Grundfos pumps, the intelligent IP66 off-grid Renewable Solar Inverter (RSI) greatly expands possibilities for solar energy water supply systems with substantially reduced lifecycle costs.

BENEFITS

- IP66 enclosure class means the RSI is weatherproof and allows outdoor installation
- Advanced MPPT software which continuously optimises the system with respect to temperature as well as the solar panel conditions
- Quick setup Wizard with pre-defined parameters suits the Grundfos submersible MS motor.

Renewables	Control (depend on connected sensor)	Features														Products										
		single pump duty / standby	parallel cascade operation	Non e-pump	Relay outputs	Grundfos GO communication	R100 Infrared communication	BACnet data communication	LONWorks data communication	PROFIBUS DP/ PROFINET data communication	Modbus data communication	EtherNet/IP data communication	Modbus TCP data communication	3G/4G cellular data communication	GRM/ GiC data communication (Grundfos Remote Management)	GENIBUS data communication	Ethernet (VNC Server) data communication	No external sensor required	Sensor (0/4-20mA / 0-10V)	Energy optimizing functions	Graphic display with user interface	Start-up wizard	Motor protection	SQ Flex, CR Flex	CR, SP, NB, NK, MTR, CM, TP	
Solar panels / Wind turbines																										x
SQ Flex	L	x				CU 200	CIU 903	CIU903									CIU 283 *13)	x							x	x
RSI											RSI	RSI						RSI								
CR Flex	L	x						x	x								CIU 283 *13)								x	x

A= Autoadapt, Dp= Differential Pressure, P= Const. Pressure, PP= Proportional Pressure, T= Const. Temperature, DT= Differential Temperature, F= Const Flow, S= Const. Speed/Frequency, L=Level, pH=pH-Wert, Cl2= Chlorine, ClO2=Chlorine dioxide, O3=Ozone, PAA=Peracetic acid, H2O2=Hydrogen peroxide

**9) CIM interfaces
 10) CIU interfaces
 *1) incl. differential pressure sensor
 *12) 4-20 mA Sensor required
 x available

*13) order a CIU 903 and a CIM 280 and mount CIM into CIU 903
 CIM 280 support 3G /4G cellular technology and require an additional 3G/4G antenna and a related SIM card.

RECOMMENDED RANGE: SENSORS & FREQUENCY CONVERTER

- Grundfos Industrial Direct Sensors:**
- VFS Vortex flow sensors for liquids
 - VFI Vortex flow sensors for liquids
 - RPS Relative pressure sensors for liquids
 - DPS Differential pressure sensors for liquids
 - DPI Differential pressure sensors for liquids
 - DPI + T Differential pressure and temperature
 - RPI Pressure sensor for liquids
 - RPI + T Pressure and temperature sensor
 - Power supply SI 001 PSU for Sensors VFI,RPI,DPI (with mA output)
 - Transmitter SI 010 CNV input 0,5 -3,5/ 0-4,5 V, output 4-20mA/2-10V/ 1-5 V

- Grundfos Differential-pressure sensor, Kit DPI Grundfos**
- sensor incl. 0.9 m screened cable (7/16" connections)
 - 1 original DPI bracket (for wall mounting)
 - 1 Grundfos bracket (for mounting on motor)
 - 2 M4 screws, 1 M6 screw (self-cutting)
 - 1 M8 screw (self-cutting), 1 M10 Screw (self-cutting)
 - 1 M12 screw (self-cutting), 3 capillary tubes (short/long)
 - 3 capillary tubes (short/long), 2 fittings (1/4" - 7/16")
 - 5 cable clips (black)

Fitting kit for TPED with two sensors Grundfos Fitting kit



This table describes the ranges of the above mentioned direct sensors

Type/ range in bar:	0-0.6	0-1.0	0-1.6	0-2.5	0-4.0	0-6.0	0-10	0-16	0-25
RPI (4-20mA)	x	x	x	x	x	x	x	x	x
RPI+T (2x0-10V)	x	x	x	x	x	x	x	x	x
DPI v2 (4-20mA)	x	x	x	x	x	x	x	x	
DPI v2 +T (2x0-10V)	x	x	x	x	x	x	x	x	
DPI (4-20 mA)	x	x	x	x	x	x	x		
RPS (0.5-3.5V)	x	x	x	x	x	x	x		
RPS+T (2x0.5-3.5V)	x	x	x	x	x	x	x		
DPS (0.5-4.5V)	x	x	x	x	x	x	x		
DPS+T (2x0.5-4.5V)	x	x	x	x	x	x	x		

Type/ DN range :	DN 18	DN 25	DN 32	DN 40	DN 50	DN 65	DN 80	DN 100
VFS (0.5-3.5V) up to 400l/min			x	x	x	x	x	x
VFS-QT (0.5-3.5V)	x	x		x	x	x		
VFI (4-20mA) up to 240 m³/h	x		x	x	x	x	x	x
Flow range* [m³/h] ([l/min])	0,3-6 (5-100)	0,6-12 (10-200)	1,4-28 (20-400)	2-40 (32-640)	3,3-66 (50-1.000)	5-100 (80-1.600)	8-160 (130-2.600)	12-240 (200-4.000)

- Pressure sensor, MBS 3000**
- Electrical connection: plug (available as relative or absolute pressure sensor) (absolute pressure is sometimes needed for CR-Monitor)
- Pressure sensor kits, MBS 3000**
- consisting of pressure transmitter with 2 m screened cable
 - Connection: G 1/2 A (DIN 16288 - B6kt) 5 cable clips (black)
- Flowmeter, MAGFLO MAG 3100/5000**
- Temperature sensor, TTA**
- Accessory for temperature sensor with 1/2 RG connection
- Ambient temperature sensor, WR 52**
- Differential-temperature sensor, ETS D**
- Dryrunning Protection, Liqtec**
- for CRE, CRIE, CRNE, MTR, SPKE, CRKE, CME
 - Protects the pump against dry-running.
 - Protects the pump against too high liquid temperature (130 °C ± 5 °C).
 - Can monitor the motor temperature if the PTC sensor in the motor has been connected.
 - Has a fail-safe design. If the sensor, sensor cable, electronic unit or power supply fails, the pump stops immediately.
 - voltage 200-240 or 80-130 Volt,
 - Available with different cable length



- Hydrostatic pressure sensor, MPS**
- Available with different cable length
 - WRAS & ACS on request for large sizes
 - Piezo-resistive measurement principle
 - Output 4-20 mA
- Ultrasonic transmitter Sietrans Probe LU**
- for level, volume, flow
- operating conditions according to IEC 60770-1
 - humidity 45 to 75% relative humidity
 - ambient pressure 860 to 1060 mbar
 - output 4-20 mA ± 0.02 mA accuracy
 - Hand programmer for Sietrans Probe LU
- Float switches MS1**
- 1 float switch MS1
 - 2 float switch MS1
 - 3 float switch MS1
 - 4 float switch MS1
 - Also available with wallhanger
 - Also available for explosion protection (EX)
 - Available with different cable length
- Digital water parameter sensors S::CAN**
- Modbus interface to CU 382 control unit
 - Onboard storage of calibration data
 - Temperature measurement and compensation included for all sensors
 - Pre-calibrated (pH, ORP, conductivity sensor)
 - Diaphragm-covered amperometric sensor principle for disinfectant sensors
 - Low pH dependency for free-chlorine sensors
- Available parameters:**
- Free Chlorine
 - Total chlorine
 - Chlorine dioxide
 - Hydrogen Peroxide
 - Peracetic acid
 - ORP
 - PH
 - Conductivity

- Sensors for WW-pumps (e.g. S-, SE, SEG range)**
- Sensors for water in oil, vibration, moisture
- Sensor interface IO 113 and SM 113
- CUE Frequency converters for three-phase pumps**
- Grundfos CUE is an addition to our E-solution programme of speed-controlled pump systems for industry, building services, municipal water supply, municipal wastewater, and irrigation applications. This new comprehensive series of wall-mounted frequency converters with E-pump functionality and user interface is a complimentary product to Grundfos E-pumps with integrated frequency converter.
- With a CUE solution you can control the speed of virtually any Grundfos pump irrespective of size, power range, and application area. Adjustment of the pump performance to the demand, thus saving energy. Easy installation, as the CUE is designed for GRUNDFOS pumps.
- Short-circuit-protected output; no motor-protective circuit breaker required.
- fault indication via display and a relay, if fitted.
- External setpoint influence**
- Together with connected sensors, the CUE offers these control modes:
- proportional differential pressure
 - constant differential pressure
 - constant pressure
 - constant pressure with stop function
 - constant level
 - constant level with stop function
 - constant flow rate
 - constant temperature.
- Available for mains voltage:**
- 1 x 200-240 V / 3 x 200-240 V / 3 x 380-500 V / 3 x 525-600 V / 3 x 575-690 V.
 - The CUE can also be controlled by an external signal or CIU via, GSM/GPRS,
 - Modbus TCP; PROFINET IO, Modbus RTU, Profibus DP, LON, BACnet MS/TP or GRM.

- Remote Sensors for Control DDD**
- Wireless sensors to mount at remote areas to communicate via GPRS/GSM (wireless) to with the controller of demand driven distribution system (DDD).
- RSI Renewable Solar Inverter:**
- The RSI is designed to work with a broad range of Grundfos submersible and surface pumps. A solar energy water supply system with a solar inverter can run a Grundfos pump up to 37 kW in size.
- The RSI is incredibly easy to setup and install, and pairs easily with SP submersible pumps as well as a broad range of Grundfos pumps, creating a modular system which allows maximum components flexibility. With an IP66 enclosure class rating, the RSI is resistant to rain, dust and sand, meaning there is no requirement for a weatherproof cabinet with ventilation and air filter.
- Advanced MPPT software continuously optimises the system by compensating for environmental effects on solar panel array, improving power and water output
- AC/DC compatible You can switch the solar inverter to mains power or generator if required, because the drive is compatible to both AC and DC power input without the need to change any parameter settings.



RECOMMENDED RANGE: COMMUNICATION & MOTOR PROTECTION

CIM / CIU Fieldbus communication interfaces

For complete control of pump systems, the Grundfos fieldbus concept is the right solution. The Communication Interface Module (CIM) and the Communication Interface Unit (CIU) enable data communication via open and interoperable networks such as PROFIBUS DP, Modbus RTU, LONWorks, BACnet MS/TP, Cellular 3G/4G interfaces, Modbus TCP, PROFINET IO, BACnet IP, WITS-DNP3, EtherNet/IP or Grundfos iSolution Cloud (GiC) or Grundfos Remote Monitoring (GRM). Complete process control based on standard functional profiles.

CIM 050 For communication with GENiBus
CIM 060 For radio communication from Dedicated Controls or SEG AutoADAPT to Grundfos GO

CIU 100 For communication via LON (pumps)
CIM 100 For communication via LON (pumps)
CIM 110 For communication via LON (booster / newer twinpumps)

CIU 150 For communication via PROFIBUS DP
CIM 150 For communication via PROFIBUS DP
CIU 152 For communication via PROFIBUS DP (WW-AutoADAPT)

CIU 200 For communication via Modbus RTU
CIM 200 For communication via Modbus RTU
CIU 201 For communication via Modbus RTU (with IO board)
CIU 202 For communication via Modbus RTU (WW-AutoADAPT)

CIU 260 * For 3G/4G cellular communication or SMS
CIM 260 * For 3G/4G cellular communication or SMS
CIU 261* For 3G/4G cellular communication or SMS (with IO board)
CIU 262 * For 3G/4G cellular communication or SMS (WW-AutoADAPT)
* require a 3G/4G antenna and a related SIM card. To create a CIU 260 order a CIU 900 and CIM 260, to create CIU 261 order a CIU 901 and a CIM 260, to create CIU 262 order CIU 902 and CIM 260).

CIU 300 For communication via BACnet MS/TP
CIM 300 For communication via BACnet MS/TP

CIU 500 For communication via PROFINET IO/ Modbus TCP/ BACnet IP/ to Grundfos iSolution Cloud or GRM / EtherNet/IP
CIM 500 For communication via PROFINET IO/ Modbus TCP/ BACnet IP/ to Grundfos iSolution Cloud or GRM / EtherNet/IP

CIU 501 For communication via Modbus TCP/ to Grundfos iSolution Cloud or GRM (IO board)
CIM 531 For WITS-DNP3

CIU 900 Interface unit to add a CIM for Grundfos products that do not support the internal add-on modules (IO board)
CIU 901 Interface unit to add a CIM for Grundfos products that do not support the internal add-on modules (IO board)
CIU 902 For wireless infrared communication (WW-AutoADAPT)
CIU 903 For wireless IR communication to SQ Flex

E-Box 150 PROFIBUS DP unit unit for smart digital DDA S dosing pump
E-Box 200 Modbus RTU extension unit for smart digital DDA dosing pump
E-Box 500 Modbus TCP/ PROFINET IO/ GiC GRM IP extension module for DDA S dosing pump

GRM - Grundfos Remote Management / GiC (Grundfos iSolution Cloud)

Complete performance data available from Internet-based supervision allows optimisation of your pump or booster system.

- Receive SMS/ e-mail alarms on issues you need to act on immediately, for example low system pressure, water shortage or power supply problems
- Adjust settings remotely via Internet
- Ensure your system is correctly dimensioned to meet demand
- Analyse consumption profiles and follow energy usage

Internet-based supervision also allows you to optimise the service and maintenance program for your pump or booster system. Data from pump installations is transferred to a central database and published to subscribers on a secure web server. Users have access to data from pump installations that are registered their own account.

CIM 280 3G/4G cellular interface to GRM /GiC
CIU 280 3G/4G cellular interface to GRM /GiC
CIU 281 3G/4G cellular interface to GRM /GiC (IO board)
CIU 282 3G/4G cellular interface to GRM /GiC (WW AutoAdapt)
CIU 283 3G/4G cellular interface to GRM /GiC (SQFlex, MGFlex)

Note: It require a 3G/4G antenna and a related 3G/4G SIM card with international SMS roaming active. To create a CIU 280/ 281/ 282 283 order a CIU 900/ 901/ 902/903 and a CIM 280 and mount the CIM into CIU box). Note: GRM requires a contract with Grundfos for to hosting of data.

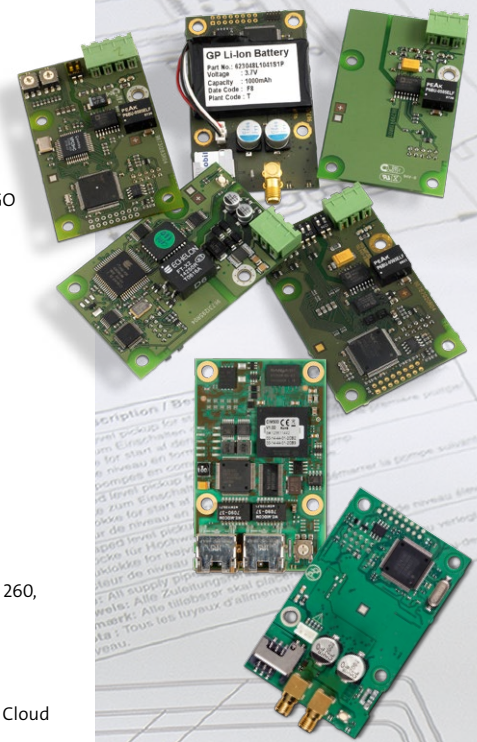

Grundfos GO -Remote Control

for all Grundfos pumps & controllers designed for wireless communication.

Grundfos GO gives you intuitive handheld pump control and full access to the Grundfos online tools on the go. So get ready to save valuable time on pump control, reporting and data collection with the most comprehensive mobile platform on the market.

MI 401 ALPHA READER

MI401 is connection device for hydronic balancing of 2 pipe heating systems with has an ALPHA3 or ALPHA2 model E pump installed by using a mobilephone App.

Motorprotection unit, MP 204

Monitoring and protection of pump installations.

- Protection against dry running and too high motor temperature
- Constant monitoring of pump energy consumption
- Reading of operating data via R100 or Grundfos GO.
- Connection to large control systems via bus communication (GENiBus)
- Options: Data communication to Profibus, Modbus, GSM/GPRS, GRM, PROFINET Modbus TCP via CIU units
- Ready made control cabinets available: Control MP 204
- up to 120 A
- external current transformers to extent the range up to 999 A
- Accuracy for most measured values : +/- 1 %
- Enclosure class: IP 20
- Ambient temperature: ± 20 to 60°C
- Relative humidity: 99 %
- Nominal Voltage: 400 VAC
- Current range: 3-999 A
- Frequency: 47-63 Hz
- IEC trip class: 1-45
- Special Grundfos trip class: 0.1-30 s
- Voltage variations: $\pm 25/+15$ % of nominal voltage
- Approvals: EN 60947, EN 60335, UL/CSA 508
- Marking: CE, cUL, C-tick

Control MP 204

Ready made control cabinets with MP 204 motorprotection, fuses, relays, switch, lamps, clamps.

- Single control for analog sensor applications

Options: Data communication to Profibus, Modbus, GSM/GPRS, GRM, Modbus TCP, PROFINET IO via CIU units

Control CUE

Grundfos Control CUE is a series of external frequency converters designed for speed control of a wide range of Grundfos pumps. The Frequency converter is delivered installed in a cabinet with main switch, circuit breaker, and an optional filter. CUE has a built-in PI controller and offers the same functionality and user-interface as Grundfos E-pumps. Power range: 2.2 kW - 90 kW.

Control CUE can be used where:

- Pump speed must be adapted according to demand, to eliminate unnecessary energy consumption
- Control functions like constant flow, constant pressure and constant water level is needed
- Status/control for pump must be integrated to SCADA/SRO systems

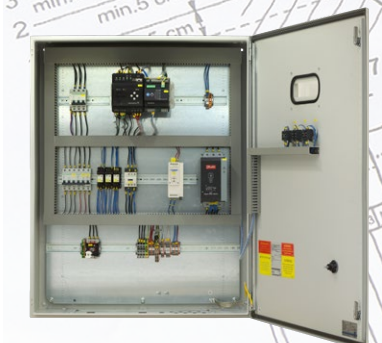

RECOMMENDED RANGE: CONTROLS

Control MPC / Control DDD

Control Cabinet with fuses, switch, controller

- Control of up to six identical pumps in parallel
- Motors from 0.37 - 75 kW can be connected (on request up to 315 kW)
- Enclosure class: IP54.
- Energy optimizing control algorithms
- User friendly color graphic display
- Start up wizard
- Easy installation and start-up
- Simple control
- Modular solution with possibility of expansion
- Application-optimised software, demand driven distribution

Applications

- Heating systems
- Air-conditioning systems
- Cooling systems
- Booster systems, Demand driven distribution
- Industrial processes
- Water supply systems.

The Control MPC is designed for these pump types:

- CR(E), CRI(E), CRN(E), CME
- NB(E), NBE(E)
- NK(E), NKG(E)
- TP
- TPE Series 1000
- TPE Series 2000
- HS
- SP
- MAGNA/ UPE series 2000

Variants for e-pumps and with integrated frequency converter

Options: Data communication via Ethernet (VNC Server), LON, PROFIBUS, Modbus RTU, BACnet MSTP, BACnet IP, 3G/4G cellular interfaces, PROFINET IO, Modbus TCP, Grundfos Remote Management System

Control MPC Series 2000

Control and monitoring units for MAGNA3, TPE3 pumps
Control Cabinet with Controller and switch

- Control of up to six Grundfos MAGNA, MAGNA3, UPE, TPE3 of identical pump type and size.
- Supply voltage: 1 x 100-240 V.
- All motor sizes can be connected.
Power supply for pumps have to be done external
- Enclosure class: IP54.
- Energy optimizing control algorithms
- User friendly graphical display
- Start up wizard
- Easy installation and start-up
- Up to 6 differential pressure zone sensors possible
- Application-optimised software

Applications

- Heating systems
- Air-conditioning systems.

Optimal adjustment of the performance to the demand by closed-loop control of these parameters:

- proportional differential pressure
- constant differential pressure
- differential pressure (remote) *
- flow rate *
- temperature *
- temperature difference. *
- * External sensor required

Options: Datacommunication interfaces to LON, BACnet MS/TP, Modbus RTU, PROFIBUS DP, 3G/4G cellular interfaces, PROFINET IO, Modbus TCP or Grundfos Remote Management System



Pressure manager PM1, PM2

PM 1 and PM 2 pressure managers are designed for automatic start/stop control of Grundfos pumps and other water supply pumps in Blocks of flats, house and garden, agriculture and similar applications

- User-friendly interface
- Free position in installation
- Flexible power supply
- Incorporates functions which protect the pump.

Max. operat. pres.: 10 bar

Liquid temp.: 5 °C to + 40 °C (up to 60 °C if VDE approval is not required*)

DID - Dosing Instrumentation Digital

Preassembled system for measurement and control of up to 3 water quality parameters

Monitoring of typical water quality parameters as well as precise control of disinfectant addition or pH adjustment is essential for many water treatment processes.

The new Grundfos by S::CAN DID systems are the perfect combination of S::CAN's state-of-the-art digital sensor technology and Grundfos experience in PID controlling of dosing and disinfection processes. DID systems are designed to match Grundfos dosing pumps, gas dosing systems and systems for the generation and dosing of chlorine dioxide and hypochlorite. DID systems are available as compact systems with bypass flow cell or as kits for applications with tank-immersed sensors. The DID is easy to set up due to the pre-assembled and pre-calibrated configurations. Installation is easy due to the Fieldbus-based communication with both system control and sensors. The control unit CU382 included in DID offers a wide variety of set up options for the freely assignable digital and analog in- and outputs as well as for the controller functions.

DID system with bypass flow cell:

Intended for monitoring and control of disinfectants, pH, ORP, conductivity and temperature. The system is preassembled on a common backplate and includes a control unit CU382, the water parameter sensor(s) with cable(s) to the control unit and the hydraulic assembly. DID system with tank immersed sensor(s) Intended for monitoring and control of pH, ORP, conductivity and temperature. The sensor(s) are placed directly in the tank or basin without the need for a bypass line and flow cell. The system is a kit for assembly on site and includes a control unit CU382, the water parameter sensor(s) with cable(s) to the control unit and tank immersion sensor holder(s).

CU 382 control unit:

- Intuitive plain-text operation
- Data logger functionality for settings, calibration data and measured values

AR control unit

The AR control unit is available in two versions:

- standard version mounted on the terminal box of the dosing pump.
- version for wall mounting:

The control unit is mounted on a wall mounting plate.

- Up to 3 controller outputs, freely assignable to input parameters and adjustable as PID or 2-P controllers

- Modbus RTU interface (slave)
- Modbus sensor interface
- Data interchange with USB stick
- Down- and upload of setting files
- Flexible assignment of in- and outputs (in: 2(3)x digital, 1x analog (0)4-20mA, out: 2x digital, 3x analog 4-20mA, 1x alarm relay)
- Wide-range power supply
- Water parameter sensors:
- Modbus interface to CU 382 control unit
- Onboard storage of calibration data
- Temperature measurement and compensation included for all sensors
- Pre-calibrated (pH, ORP and conductivity sensors)
- Diaphragm-covered amperometric sensor principle for disinfectant sensors
- Low pH dependency for free-chlorine sensors

Available parameters:

- Free Chlorine
- Total chlorine
- Chlorine dioxide
- Hydrogen Peroxide
- Peracetic acid
- ORP
- PH
- Conductivity

Flow cell hydraulic assembly:

- Max. pressure at inlet: 3bar
- Inlet/outlet hose connections suitable for many hose sizes
- Shut-off valve
- Flow restrictor (limits to max. approx. 60l/h)
- Flow switch (activated at approx. 30l/h)
- Flow cell with sample water withdrawal assembly
- Max. pressure on outlet: 0,5 bar
- Tank immersion sensor holder(s)
- For use with site supplied pipe with OD. 50mm (DN40) or inch pipe with OD. 2"
- Probe guard(s) to protect the sensor tips from damage
- Prepared for add on of compressed air cleaning assembly



GRUNDFOS FMC



FLOOD MITIGATION CONTROLLER
 FLOOD MITIGATION CONTROLLER IS A CONTROLS SOLUTION TO OPERATE AND CONTROL THE PUMPING STATION AUTOMATICALLY BASED ON PLC AND WIRE/WIRELESS LINES.

BENEFITS

Traditionally a flood control station in many countries is quite manually operated, with many switches and controls that requires workforce 24/7 to be available in the station. With our new solution, only one control unit is needed, and we can provide an intuitive interface with remote access on different platforms.

Conventional pumping station Gate pumping station

- Less cost compared to existing control system
 - Saving energy consumption
 - Flexibility and expandability
 - Wireless control
 - Easy maintenance
 - Data storage
 - Unique solution by pump station specialist
 - User friendly interface (Touch screen)
 - Grundfos One stop solution provider
-
- Electrical overview for easy maintenance via the HMI display and PC.
 - Trends and reports FMC provides the trends of power, current, operating hour and temperature of individual equipment.
 - Electrical overview for easy maintenance via the HMI display and PC.
 - Complete overview: Real time update on the system via one integrated system
-
- Maintenance: All errors of connected equipment to FMC are indicated at display. FMC provides operator to check errors and to set the maintenance plan in easy way.
 - User-friendly system Flexibility of system configuration base on site condition
 - Operation sequence setting Operation sequence set for same operation time.

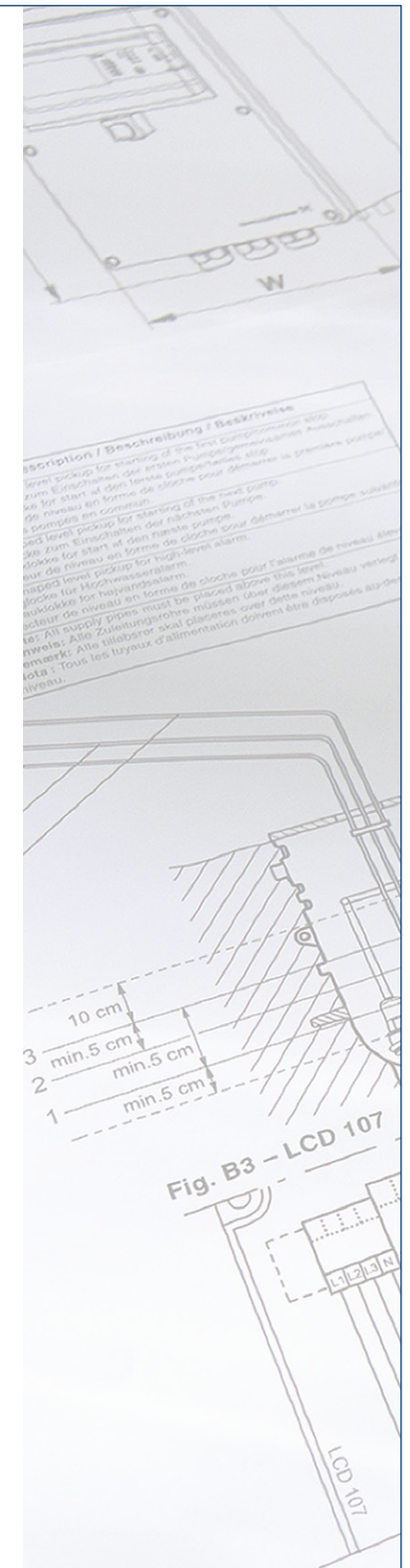
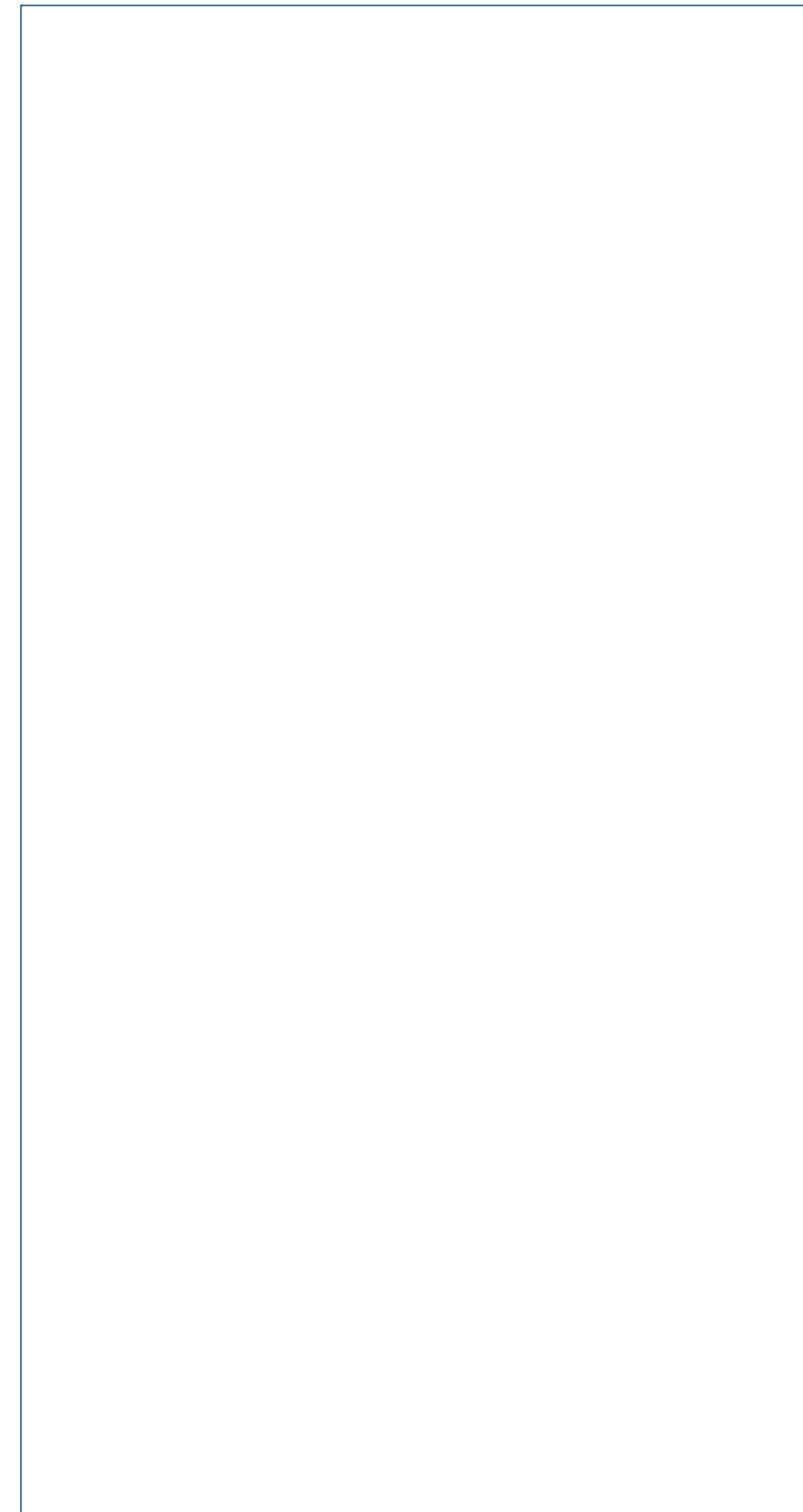
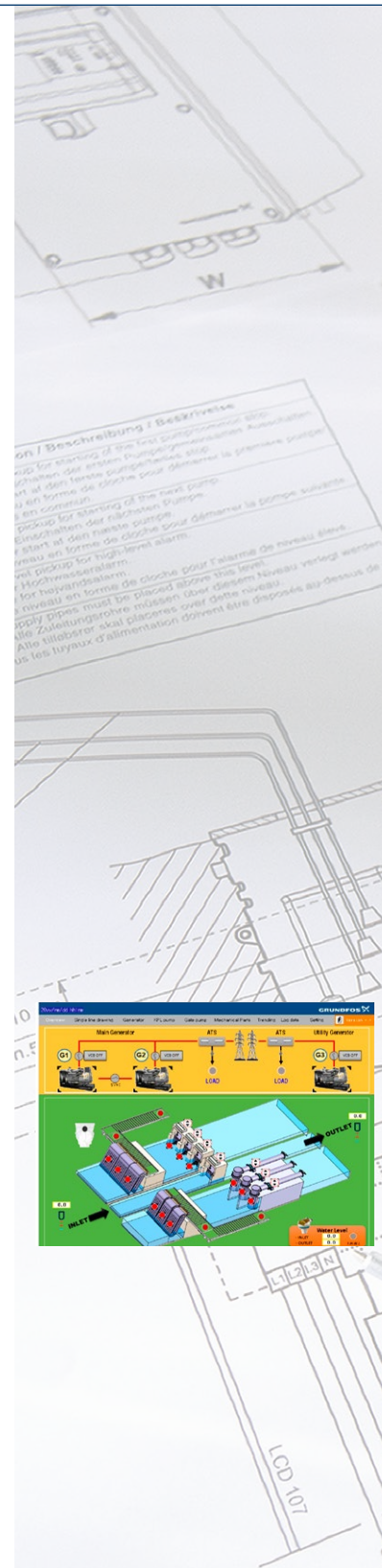

RECOMMENDED RANGE: SEWAGE CONTROLLER

CU 100

Small pump control units
The control unit CU 100 is designed for the starting, operation and protection of small pumps.
The control unit is suitable for the following operating currents:

- Single-phase: up to 9 A.
- Three-phase: up to 5 A.

Supply voltage: 1 x 230, 3 x 230 and 3 x 400 V, 50/60 Hz.

- Control of one pump
- Start/stop by means of a float switch or manual start/stop.
- Several variants for single- and three-phase pumps
- Single-phase control units are supplied with capacitors and with or without float switch.
- Three-phase control units are supplied with a float switch
- IP54 cabinet with screwed metric cable entries.

LC, LCD 107, 108 and 110

Pump controllers with pneumatic signal, float switch or electrodes for

- Pumping stations
- Filling/emptying of tanks.

Supply voltage: 1 x 230, 3 x 230 and 3 x 400 V, 50/60 Hz.

- Automatic alternating operation (LCD)
- Automatic test run preventing shaft seals from seizing up during long periods of inactivity
- Water hammer protection
- Starting delay after power failure
- Stop delays
- Automatic alarm reset (if required)
- Automatic restart (if required)
- Liquid level indication
- High-level alarm
- Motor overload protection relay
- Protection against motor overheating via input from PTC resistor/thermalswitch.

Optional

- SMS modem with built-in hour and start counter (information on mobile phone)
- Hour counter Start counter
- Signal lamp, Acoustic signal, External mains switch.

LC, LCD 115 with Level transmitter

The level transducer transmits an analog level signal that will start the pumps depending on level setting configured in the controller.
To protect the pump pit to provide high level notification it is possible to install a high level float switch that will trigger a high water level alarm.

- Automatic alternating operation (LCD)
- Water hammer protection
- Alarm protection
- Protection circuits
- Automatic test run preventing shaft seals from seizing up during long periods of inactivity
- Starting delay after power failure
- Stop delays
- Automatic alarm reset (if required)
- Automatic restart (if required)
- Liquid level indication
- High-level alarm

Optional

- SMS modem with built-in hour and start counter (information on mobile phone)
- Hour counter Start counter
- Signal lamp, Acoustic signal, External mains switch.

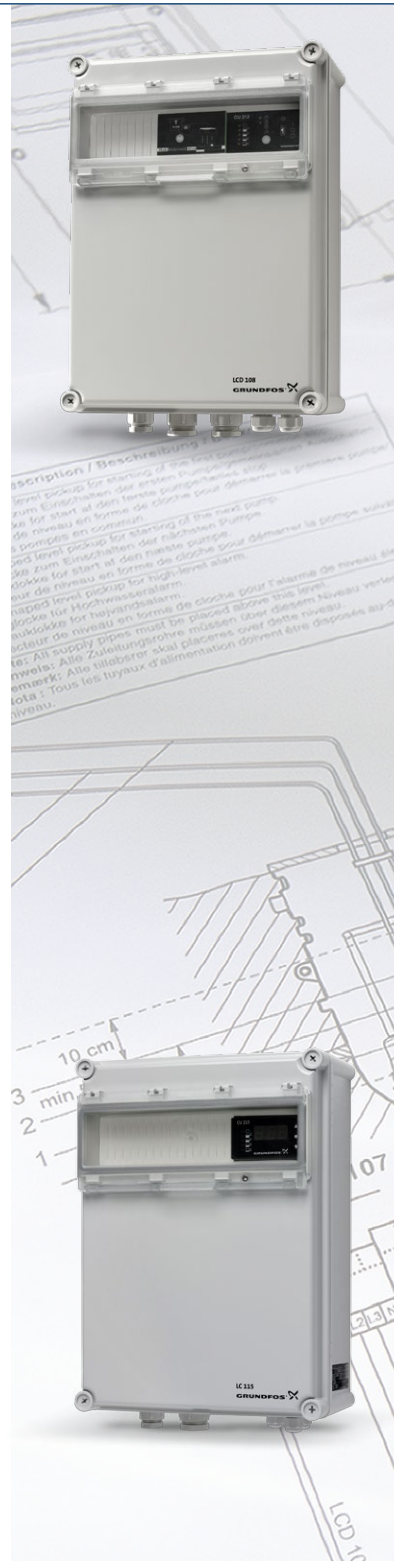

Multilift controller (LC 221)

Pump controllers (LC 221) with analogue ultrasonic signal or pressure switch
• Lifting station controller to empty collecting tanks with one or two pumps.

Supply voltage: 1 x 230, 3 x 230 and 3 x 400 V, 50/60 Hz.

- Automatic alternating operation
- Automatic pump changover at fault
- High-level alarm
- Motor overload protection relay
- Protection against motor overheating via input from PTC resistor/thermalswitch.

- automatic test run during long periods of inactivity (24 hours after last operation)
- re-starting delay after returning from battery operation to mains operation (resulting in an even mains load when several appliances are started up at the same time)
- accumulator back-up in case of mains supply failure (accessory)
- setting of delay times:
 - stop delay - reduces water hammer at e.g. long pump distances
 - starting delay
 - alarm delay - for short term high peak signal at flushed inflow
- automatic current measurement for alarm indications
- setting of current values:
 - overcurrent
 - rated current
 - dry running current.

- operation indication of:
 - operation modus (auto, manual)
 - operating hours
 - impulses
 - highest measured motor current.

- alarm indication of:
 - pump status (running, fault)
 - phase sequence failure
 - thermal switch failure
 - high water alarm
 - warning time for service/maintenance interval (0, 3, 6 or 12 months)
 - selection of automatic alarm resetting
 - failure log of up to 20 alarms
 - selection between different start levels
 - selection of connected sensor type
 - calibration of sensor
 - Further settings a PC-Tool can be connected
 - Motor protection by overload protection relay and/or measurement on board

As standard, the LC 221 has four signal outputs for

- pump is running
 - pump failure
 - high water level alarm
 - common failure
- and six digital inputs for
- connecting the ultrasonic sensor
 - connecting up to 4 float and pressure switches instead of analog sensor.

- Connection of an external level alarm outside the Multilift.
- Lifting stations are often installed in a well inside the basement - the lowest point in the building. In case of e.g. groundwater inflow or water pipe burst an alarm will be indicated via the level control.
- connecting a pressure sensor board
 - external alarm reset
 - connecting the thermal switch of the motor.

Optional: SMS modem with built-in hour and start counter (information on mobile phone)

Optional: Hour counter Start counter

Optional: Signal lamp, Acoustic signal, External mains switch. The LC 221 enables on/off control of 1 or 2 waste water pump based on a continuous analogue signal from ultrasonic sensor, pressure sensor or digital signal of float switches

LLC 100W

The level controller LLC 1000W is used for level-dependent on/off switching of grey wastewater pumps via electrodes.
They are primarily used where the levels of conductive, non-flammable liquids in tanks or pits must be strictly maintained, or where these liquids require very shallow pumping.

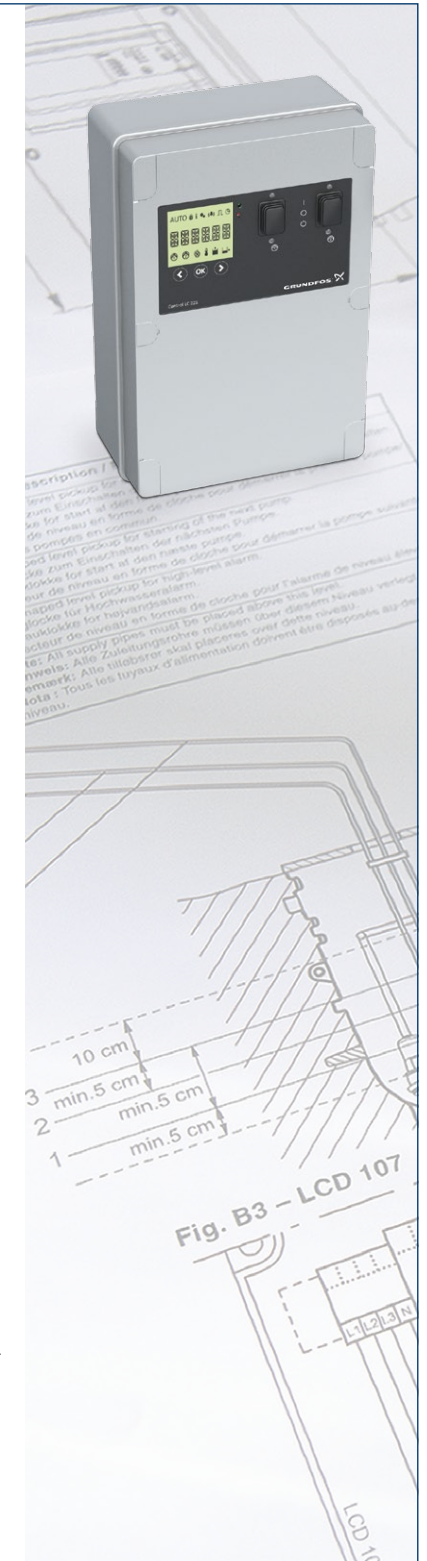

RECOMMENDED RANGE: SEWAGE CONTROLLER AND RAINWATER CONTROLLER

Dedicated Controls

Dedicated Controls are suitable in wastewater applications for emptying wastewater pits (up to six pumps) by float switches or analog sensors.

- Pressurized pumping stations
- Network pumping stations
- Commercial buildings.

Supply voltage: 1 x 230, 3 x 230 and 3 x 400 V, 50/60 Hz.

Ambient temp.: -20°C to +50°C

Enclosure class: IP 5x

Available as complete Control cabinet and as separate modules

- Automatic energy optimization
- Easy installation and configuration
- Configuration wizard and color display
- Electrical overview
- Advanced data communication
- Advanced alarm and warning priority
- Supports several languages
- Daily emptying
- Mixer control or flush valve
- User-defined functions
- Anti-blocking
- Start level variation
- Advanced pump alternation with pump groups
- SMS scheduling and optional: wireless interlocking

Versions with VFD drive (CUE) for energy optimized operation

PC Tool wastewater for easy setup, log data, monitor parameter etc.

Option: Data communication to SCADA via GENIBus, PROFIBUS DP, PROFINET IO, Modbus RTU, Modbus TCP; 3G/4G cellular interfaces/ SMS (wireless) or Grundfos Remote Management system

Option: Mixer/ flush valve

Option: Battery backup

Option: MP 204 for motor protection

Option: IOT13 for sensors (e.g. WIO)

Option: SM113 for sensors

Option: Ex-safety barrier

Wastewater AUTOADAPT

Wastewater AUTOADAPT pumps has integrated sensors and needs no external sensors, they adapt automatically up to 4 start/ stop levels.

Only one cable to the pump, powerline communication to CIU communication module. Integrated motor protection

SEG AutoAdapt, 0.9 - 4 kW, pressurised domestic sewage

DP AutoAdapt, 0.9 - 2.6 kW, Drain water & groundwater

SL AutoAdapt, 0.9 - 1.5 kW, Domestic, municipal and industrial wastewater, drainage water & groundwater

EF AutoAdapt, 0.6 - 1.5 kW, Drain water, Groundwater, Wastewater with fibres

Supply voltage 1~ 230 / 3~ 400 V, 50 Hz depends on pump type

For 1 - 4 pumps in one pit

Ambient temp.: -30°C to +50°C

Enclosure class: IP 65

Options:

Data communication interfaces:

- CIU 262: SMS (to mobile phones)

- CIU 202: SCADA via Modbus RTU (cable)

- CIU 262: SCADA via Modbus TCP (Wireless)

- CIU 282: Grundfos Remote Management

- CIU 902: R100 Infrared communication

- CIU 152: Profibus DP

- CIU 902 plus CIM 500 Profinet IO or Modbus TCP

- CIU 902 plus CIM 050 GENIBus

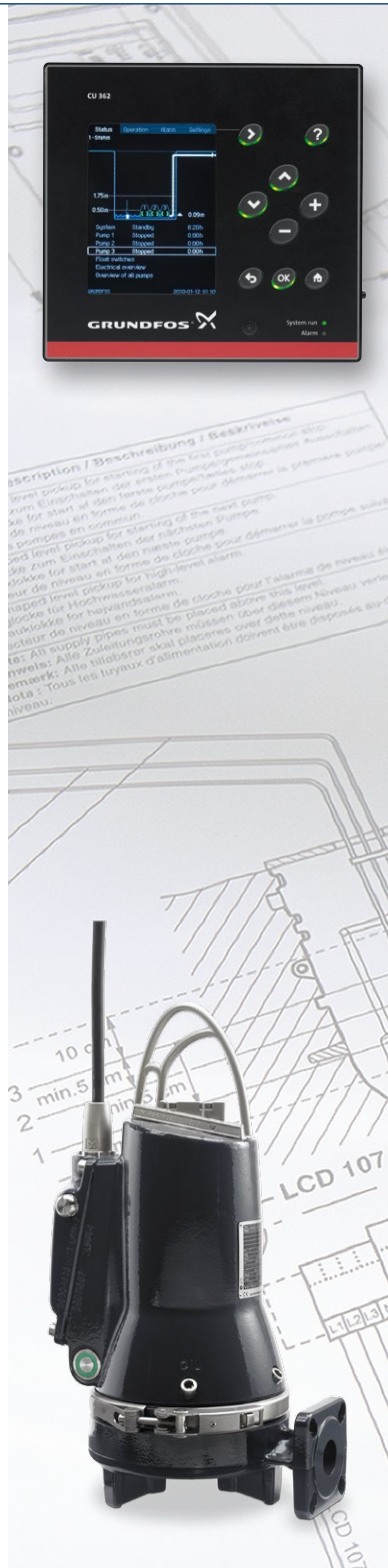

APPENDIX RAINWATER CONTROL

RCME - Rainwater Controller

Designed to supply rainwater sampling points installed in the non-residential buildings and does not require the distribution of drinking water, this Grundfos offers is under the sign of reliability, energy efficiency and operational safety.

If this system has no self-priming pump to prevent any problems likely to affect the suction (air pockets, irregular slope of the pipe, etc.), however it is equipped with a pump power of steel stainless steel tank connected to a rainwater tank hybrid.

In case of shortage of rainfall, the system switches to the installation of water potable.

This constant pressure pump and control the rotation speed has a high efficiency motor that provides water sampling points.

Features / Benefits

- Installation CE certified, 3 x 380-480 V 50/60 Hz
- Solution energy efficient pump with integrated control the speed of rotation. This pump ensures the application of a constant pressure despite the large difference between the average flow and peak flow for which the installation is designed.
- Safe operation thanks to a very high charge pump (removal problems affecting the suction piping when using self-priming centrifugal pumps normal) which pushes the rainwater to tank hybrid.
- Hybrid tank complies with the specific requirements of EN 1717.
- Feed pump (Grundfos SPO) and booster pump for rainwater (Grundfos CME-I) carried out in materials extremely resistant to corrosion.
- Exceptional reliability through the adoption of advanced technology.
- CU 374 processor providing electronic control system of rainwater collection
- Multistage centrifugal pump CME executed in stainless steel and equipped with a motor MGE (with a frequency regulator incorporated).
- Submersible pump 5"- type SPO. The SPO pump is equipped with a submersible cable 20 meters long and a lateral connection allowing installation of a control device provided with a ball float filter
- Silent installation through the use of a multistage centrifugal pump type CME
- Module ready employment, an extremely small footprint
- Possibility of transmission of various data operations and anomaly centralized management system for buildings displaying a large graphic display range of messages.
- Discharge side of the pump CME 5-4, the system is equipped with a sensor pressure (4 to 20 mA, 0 to 10 bar) and a diaphragm expansion tank (the function shutdown is activated by low or no sampling)
- Electromagnetic valve causing a failover the installation of drinking water in case of shortage of rainfall.
- In case of absolute shortage of water (drinking and rain), the system is off service by a guard against the risk of running dry integrated into the pump CME
- Order provided via a graphic display console and microprocessor management of rainwater CU361. Display, among other things following data:
 - Level hybrid tank indicating the alert levels (water level excessive / insufficient), opening and closing of the filling with water drinking, commissioning and decommissioning of the feed pump
 - Flow rate and cumulative consumption of drinking water
 - Pressure prevailing in the installation
 - Indication of water flow
 - Menu alarm with an option to save (display time)
 - Operating data for the charge pump, the service pump and the diaphragm valve between and including others the number of commutations, hours of operation and the length of cycles.

Option: Data communication to Grundfos Remote Management system.

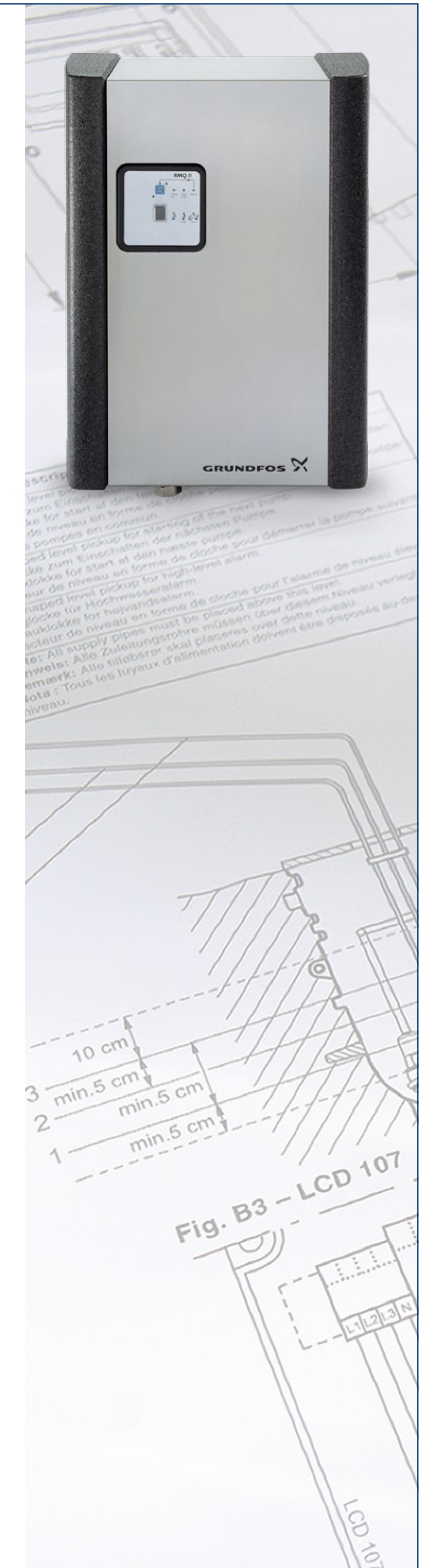

FURTHER INFORMATION

For further details we recommend to use the related databooklets and brochures

(Also available in Grundfos Product Center)

[A wide range of quality pumps](#)

[Grundfos E-pumps Pumps with built-in frequency converter](#)

[MAGNA series 2000](#)

[Grundfos CUE Frequency converters for pump control](#)

[MP204 Motor protection](#)

[Control MP 204](#)

[PM 1, PM2 Pressure manager](#)

[Hydro Multi-E / Hydro Multi-S Booster sets](#)

[Hydro MPC Booster systems](#)

[Hydro Multi-B](#)

[Control MPC Control of pumps for pressure boosting and circulation](#)

[CR Monitor](#)

[LiqTec \(Dryrunning protection\)](#)

[CIM -CIU 100/110 LONWorks data communication](#)

[CIM-CIU 150 Profibus data communication](#)

[CIM-CIU 200 Modbus data communication](#)

[CIM-CIU 250 GSM/GPRS/SMS wireless datacommunication](#)

[CIM 250 GSM/GPRS/SMS for wastewater](#)

[CIM-CIU 300 BACnet data communication](#)

[CIM-CIU 500 Modbus TCP / PROFIENT data communication](#)

[GRM Grundfos Remote Management](#)

[DP, EF, SL1, SLV and AUTOADAPT pumps](#)

[Unilift CC, AP, KP](#)

[SE1, SEV](#)

[S pumps range \(IO 111\)](#)

[multilift](#)

[Lifting stations](#)

[PS.R / PS.W / PS.G](#)

[IO 113](#)

[SM113](#)

[PVS](#)

[LLC 1000W](#)

[AMD, AMG, AFG](#)

[CU 100](#)

[LC / LCD level controller](#)

[Dedicated Controls](#)

[Control DC \(Dedicated Controls up to six pumps\)](#)

[SP Submersible pumps](#)

[SQ Flex](#)

[SQE/SQ submersible pumps](#)

[RSI Solar frequency converters for pump control](#)

[Smart digital DDA, DDC, DDE](#)

[Conex DID](#)

[Dosing pumps, measurement & control, and disinfection systems](#)

[SMART Digital DDA - DDC - DDE](#)

[DIT](#)

[Oxiperm Pro](#)

[Selcoperm](#)

[Hydrostatic pressure sensors](#)

[Float switch](#)

[Flow meter](#)

[Sitrans Probe LU \(Ultrasonic\)](#)

[DPI](#)

[DPS](#)

[VFS](#)

[VFI](#)

[CU 300](#)

[CU 301](#)

[DMH, hydraulic piston diaphragm dosing pump](#)

[DMX, mechanical diaphragm dosing pump](#)

ONLINE INFORMATION

Online information at Grundfos Product Center

Please consult the Grundfos homepage (www.grundfos.com) for more information on controls as well as for the databooklets in PDF format, for case stories, for IO-manuals etc.

Grundfos PC Tools for monitoring & commissioning

Grundfos PC Tools are available for several products to make it easy to commission and install Grundfos pumps and controllers. They are mainly developed for Grundfos sales and service people and they allow extended settings of parameter. There are several PC Tools for CU3, CU300, G100, Modular Controls, and also Tools for firmware upgrade available.

Often requested PC Tools are these:

PC Tool Wastewater:

The Grundfos PC Tool Wastewater is made for Dedicated Controls. The PC Tool is a management and service tool for on-site service and remote preparation, verification and management. The PC Tool can be used for setup, commissioning and backup of settings and parameters. Settings can be sent via e-mail for easier commissioning.

PC Tool water utility

The Grundfos PC Tool water utility is made for MP 204, IO 111 and ww AutoAdapt pumps. The PC Tool can be used for setup, commissioning and backup of settings and parameters. Settings can be sent via e-mail for easier commissioning and backup of settings and parameters. The PC Tool is a management and service tool for on-site service, verification and data logging.

PC Tool E-products

The Grundfos PC Tool E-products enables service technicians to maintain and service Grundfos E-motors, E-pumps and controllers. The PC Tool E-products communicates with GENIbus products from a PC running Microsoft Windows and require a "PC Tool link USB" adapter. The PC Tool E-products enables you to monitor the operating status of E-products e.g. a e-pump with MGE motor or CU 352, perform standard configuration of E-products, perform custom configuration of E-products and save logged data from E-products.

PC Tool CIM CIU

The Grundfos PC Tool CIM / CIU with support for Modbus RTU, Modbus TCP, GENIbus, PROFIBUS, PROFINET IO, LON, BACnet MSTP and BACnet IP are delivered with each CIM-CIU interface for easy integration and commissioning of data communication interfaces into SCADA or BMS systems.

Grundfos gives you an integration DVD that ensures easy integration into supervisory systems and fast commissioning.

You are provided with functional profiles, documentation and installation files, ready to use. Modbus, GENIbus and BACnet require a "PC Tool link USB" adapter, Profibus require a special IFAK IsPro Hardwareadapter.

All files are also available online in Grundfos Product Center

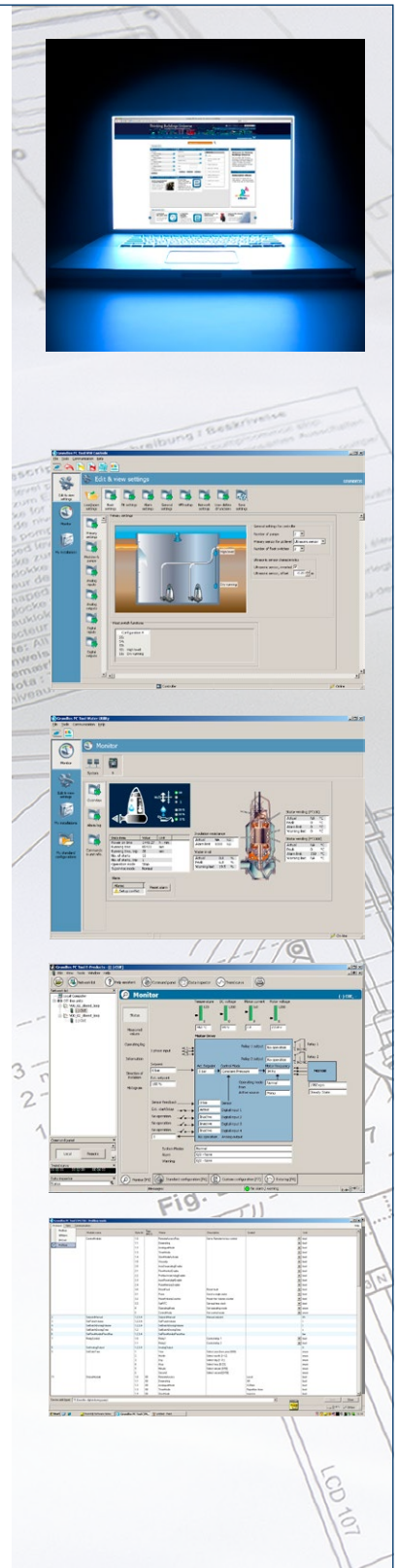

SEE THE BIGGER PICTURE

Grundfos is a global leader within water handling technology. Our passion is to bring you all the products you require to create and operate pump systems that combine reliability, cost-efficiency – and innovation. Our products are for use in water supply and wastewater infrastructure on any scale.

Grundfos has a full line of products and systems for the intake, treatment and distribution of drinking water and for the transport and treatment of wastewater. We also offer expertise and industry insight that can increase reliability and reduce lifecycle costs for water utilities.

Key product areas include:

-  Submersible pumps
-  Surface pumps
-  Sewage pumps
-  Mixers, flowmakers & recirculation pumps
-  Pumping stations
-  Monitoring & controls
-  Dosing & disinfection
-  Aeration equipment

Our products are the result of decades of engineering expertise. Supported by a worldwide service network. Visit www.grundfos.com/water-utility for more.